

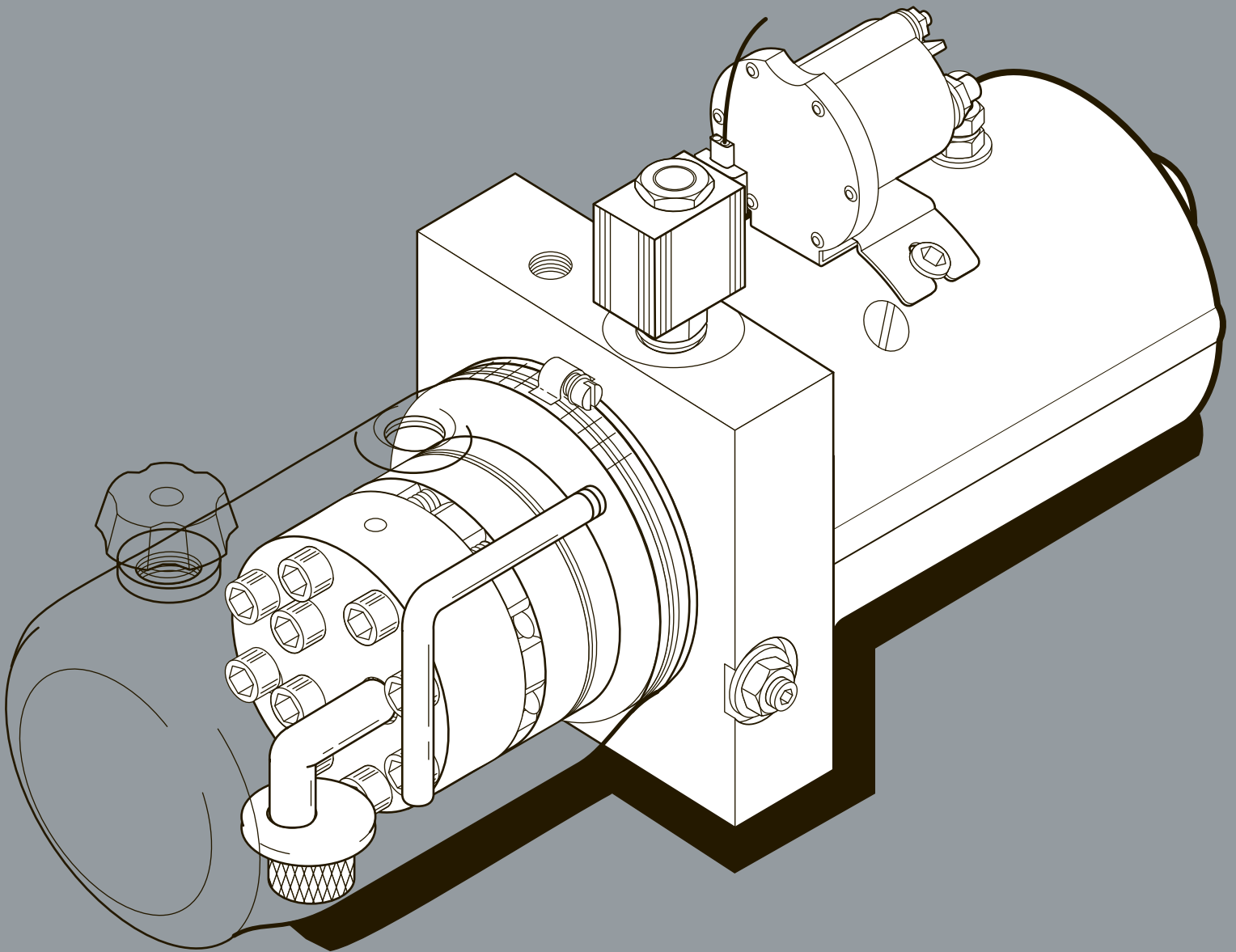

MONARCH
Hydraulics, Inc.

D.C. Hydraulic Power Systems



ISO-9001 REGISTERED

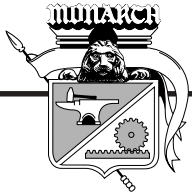

Monarch D.C. Hydraulic Power Systems

Typical Applications for Monarch DC Hydraulic Power Units

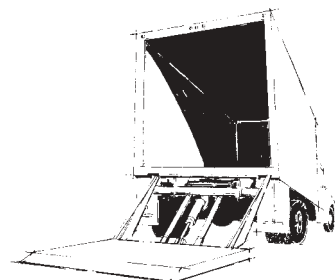
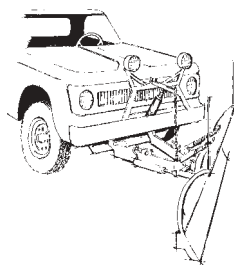
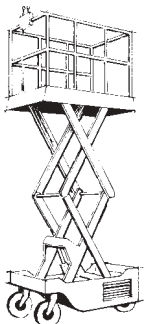
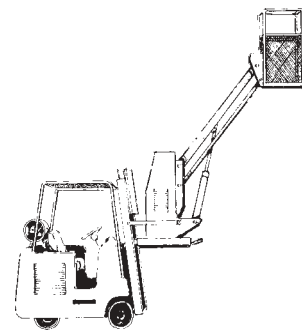
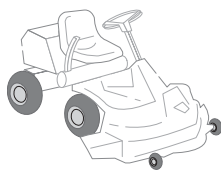
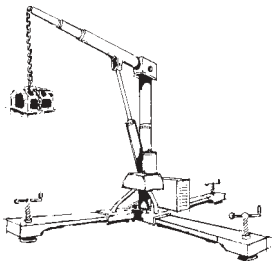
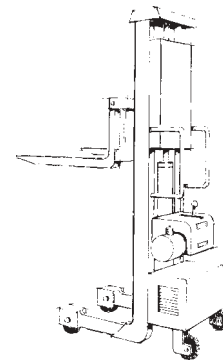
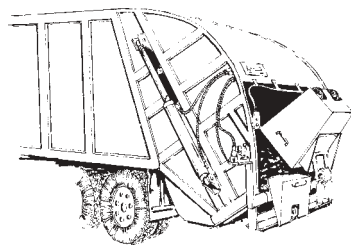
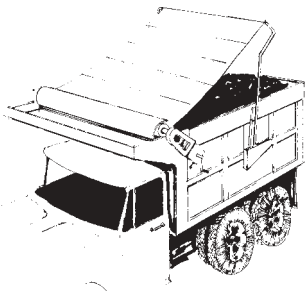
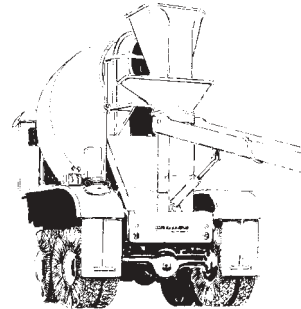
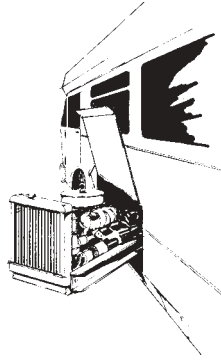
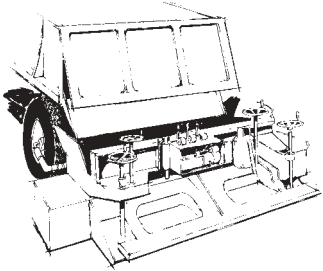

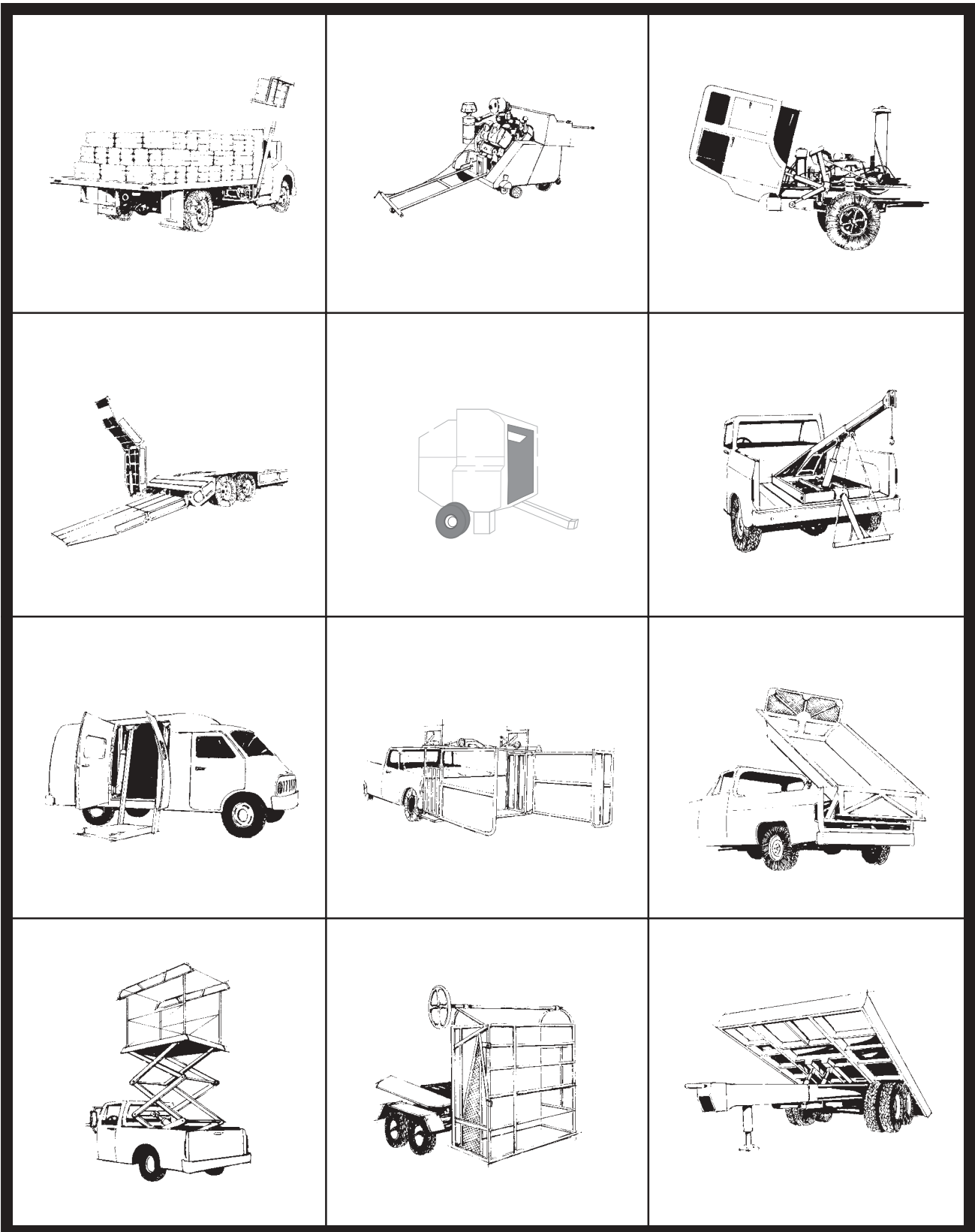



Monarch D.C. Hydraulic Power Systems

Introduction

This catalogue illustrates the technical specifications for Monarch's D.C. range of Hydraulic Power Units. Designed for compactness and durability, millions of M Series systems have been sold worldwide for actuating mobile, materials handling, transport, construction, defense, access, machine tool, ergonomic, and other labor saving devices.

The Monarch name is synonymous with precise and cost-efficient designs, robust construction and rapid backup service. Under the direction of the Jackoboice family for over 143 years the company continues to strive for your confidence by offering personal, reliable service and "Quality Machinery Since 1856" to customers in over 30 countries.

Mission Statement

Monarch designs, manufactures and delivers innovative fluid power solutions and provides unparalleled support for its customers.

Quality Policy

Monarch Hydraulics will provide its customers with products and services of continually improving quality to the mutual satisfaction of all parties.

Monarch Value Statements

- Monarch will be honest, moral and ethical.
- Monarch will accept responsibility for its actions.
- Monarch will treat people with equality.
- Monarch will remain a family business.
- Monarch will make a profit.

Prototype Policy

We invite you to try our Prototype Program for Solutions to Your Special Hydraulic Needs.

While Monarch offers a broad line of hydraulic systems and components, it is impossible to anticipate the needs of every customer, especially those developing new products. Our unique prototype program allows us to respond to your specific needs when an existing "catalogue model" does not fit your application.

To participate in this program, simply submit a print, schematic, or sketch of the hydraulic power pack that you need along with a purchase order. We will review the system requirements with you and then manufacture the system that we believe will satisfy your objectives. The unit will be invoiced at an agreed upon price and marked *Prototype*.

You have 90 days free use of this product for testing and evaluation from the date of invoice. At the end of this period you can (1) extend the testing and evaluation period for an additional 90 days or (2) purchase the unit as invoiced (and order more if needed) or (3) return the unit via prepaid transportation for full credit.

There is no risk to you. Just the opportunity to solve your hydraulic problem with the performance and quality of Monarch Hydraulics.



WARNING

- Always wear eye protection and protective clothing when working on and around hydraulic systems.
- Remove jewelry and objects that might conduct electricity while working on power units.
- Hydraulic fluid does pose a fire hazard, can cause burning or skin irritation if not properly handled.
- Fluid under pressure can pierce the skin and enter the bloodstream causing death or serious injury.
- Devices being operated by the hydraulic system should be immobilized so they cannot move and cause injury while being inspected or repaired. Disconnect from electrical source.
- Prior to performing any maintenance make sure the equipment is turned off and that any stored energy, for example pressure, is released. Also, extended equipment or cylinders should be lowered and mechanically locked as required.
- Monarch Hydraulics is not responsible for misuse or misapplication of product. If you have any questions about application, please contact local dealer.
- Fluids should be contained and disposed of properly.

Specifications, descriptions and illustrative material contained herein were as accurate as known at the time this publication was approved for printing. Monarch Hydraulics, Inc. reserves the right to discontinue models at any time, or change specifications or designs without notice or incurring obligation.

Table of Contents

Introduction	0.0	M Series D.C. Pump Data	54.0
Mission Statement	0.0	Monarch Birotational Hydraulic Power	
Quality Policy	0.0	Systems Model Data	55.0
Monarch Value Statements	0.0	Birotational i-Pump Data	56.0
Prototype Policy	0.0	Model M-3204	57.0
Features and Benefits	2.0	Model M-3230	58.0
How to Use This Product Guide	3.0	Model M-3247	59.0
M Series D.C. Power System Selection Guide	4.0	Dimensional Information for Standard	
Monarch D.C. Hydraulic Power Systems		D. C. Motors w/Performance Curves	60.0
Model Data	5.0	M Series D.C. Motor Information	61.0
Model M-255	6.0	12 Volt D.C. Performance Curves	62.0
Model M-326	7.0	24 Volt D.C. Performance Curves	77.0
Model M-304	8.0	36 Volt D.C. Performance Curves	81.0
Model M-3504	9.0	48 Volt D.C. Performance Curves	83.0
Model M-301	10.0	72 Volt D.C. Performance Curves	85.0
Model M-311	11.0	Motor Thermal Performance Data	86.0
Model M-313	12.0	M Series Reservoirs Steel and Poly	87.0
Model M-721	13.0	M Series Reservoirs	88.0
Model M-258	14.0	Mini Reservoirs	93.0
Model M-259	15.0	Valves for DC Systems	94.0
Model M-319	16.0	Motor Start Switches for D.C. Power Systems	96.0
Model M-3519	17.0	Control Stations	97.0
Model M-3519-HF	18.0	Mounting Brackets	98.0
Model M-3515	19.0	Popular Accessories for D.C. Power Systems	99.0
Model M-3516	20.0	Hand Pumps	100.0
Model M-314	21.0	Battery Cables	104.0
Model M-303	22.0	Warranty	105.0
Model M-719	23.0		
Model M-310	24.0		
Model M-3541	25.0		
Model M-3542	26.0		
Model M-3534	27.0		
Model M-3547	28.0		
Model M-3551	29.0		
Model M-3551-HF	30.0		
Model M-3554	31.0		
Model M-3552	32.0		
Model M-642	33.0		
Model M-500-4W/3W	34.0		
Model M-683	35.0		
Model M-3528	36.0		
Model M-3529	37.0		
Model M-3593	38.0		
Monarch Modular Power Units	40.0		
How to Order Your Modular Power Unit	43.0		
S-326 Pump/Motor Units	44.0		
Dimensional Information for S-326 Pump/Motor Units	45.0		
SAE AA Pump Data	46.0		
SAE A Pump Data	46.0		
12 Volt D.C. Performance Curve	47.0		
24 Volt D.C. Performance Curves	47.0		
36 Volt D.C. Performance Curves	49.0		
48 Volt D.C. Performance Curves	50.0		
72 Volt D.C. Performance Curves	51.0		
How to Order S-326 Pump/Motor Units	53.0		

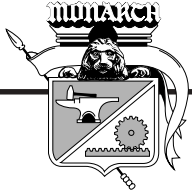

Features and Benefits

STANDARD M-200, M-300 and M-3500 SERIES:

- WIDE SELECTION OF POWER UNIT SIZES AND PERFORMANCE TO SATISFY MOST O.E.M. APPLICATIONS.
- HARDCOATED PUMP END PLATES FOR UNMATCHED DURABILITY IN DEMANDING ENVIRONMENTS AND SEVERE DUTY APPLICATIONS
- EXTERNALLY ADJUSTABLE RELIEF VALVE WITH LOCK NUT
- MONARCH'S PROTOTYPE PROGRAM: PURCHASE OR RETURN WITHIN 90 DAYS OF SHIPMENT
- 1 YEAR LIMITED WARRANTY ON SYSTEM
- MONARCH'S PERSONAL CUSTOMER SERVICE
- 24 HOUR SHIPMENT ON MOST PARTS ORDERS
- OVER TWO MILLION M PUMPS SOLD
- FAMILY OWNED AND OPERATED SINCE 1856

OPTIONS

- CUSTOM MOTORS, VALVES, RESERVOIRS, CONTROL STATIONS AND CIRCUITS
- VALVE MANIFOLDS - REMOTE OR MOUNTED DIRECTLY TO THE POWER UNIT
- MONARCH CYLINDERS OFFER SINGLE SOURCE AND SYSTEM INTEGRITY



How to Use This Product Guide

- I. Select the **Circuit** that will satisfy your design objectives (refer to page 4.0). Contact Monarch if you require assistance.
 - II. Select the **Model** that will provide the desired Valve Activation (Manual or Solenoid) listed in the Power System Selection Guide (refer to page 4.0).
 - III. Follow the “**How To Order Your M-200, 300, M-3500, or S-326 Power System**” provided after each Model description. **Only the most popular combinations are listed for the particular system.** Custom configurations are available and should be discussed with the Monarch Factory.
 - IV. The operating and design characteristics for all of the basic components are listed on pages 54.0 - 103.0 of this guide.

Select Pump on Page 54.0.
Select Motor on Page 61.0.
Select Reservoir on Page 87.0 - 93.0.
Select Valve(s) on Page 94.0 or 95.0.
Select Motor Starting Switch on Page 96.0.
Select Control Station on Page 97.0.
Select Mounting Bracket on Page 98.0.
Select Popular Accessories on Page 99.0.
Select Hand Pump on Page 100.0 - 103.0.
 - V. Nominal **Dimensions** are shown for all basic components. Dimensions may be found for your particular system by deleting the component shown on the unit drawing and adding the dimension for the same item you have selected. Note: Dimensions may vary slightly and should be confirmed by the Monarch Factory if unit is to be installed in space with minimum clearance.
 - VI. When selecting a **Reservoir**, consideration should be given to dissipating heat, separating air from the oil, and settling out contamination in the oil. There must always be a reserve of oil in the reservoir when all cylinders are fully extended and not overflow when all cylinders are fully retracted. Monarch reservoirs must be vented. Contact the factory for proper reservoir sizing for your application.
 - VII. **Motor Thermal Data.** Determine that the motor selected is thermally suited for the "run time" required by consulting the Motor Thermal Performance Data located on page 86.0
- Note: Not all options are available on every D.C. System. Contact the Monarch Factory for assistance.

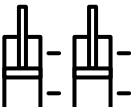
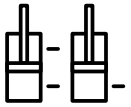

M Series D.C. Power System Selection Guide

CIRCUIT	DESCRIPTION	MODEL	PAGE
	PUMP + MOTOR	M-255 M-326 S-326	6.0 7.0 54.0 - 63.0
	PUMP + MOTOR + RESERVOIR	M-304 M-3504 M-3598* M-3504* M-3204	8.0 9.0 40.0 41.0 57.0
	OPERATES SINGLE ACTING CYLINDER		
	PUMP + MOTOR + RESERVOIR + MANUAL VALVE	M-301 M-311 M-313 M-721 M-3513*	10.0 11.0 12.0 13.0 41.0
	PUMP + MOTOR + RESERVOIR + SOLENOID VALVE	M-258 M-259 M-319 M-3519 M-3519-HF M-314 M-303 M-719 M-3519*	14.0 15.0 16.0 17.0 18.0 21.0 22.0 23.0 41.0
	OPERATES DOUBLE ACTING CYLINDER		
	PUMP + MOTOR + RESERVOIR + MANUAL VALVE	M-310	24.0
	PUMP + MOTOR + RESERVOIR + SOLENOID VALVE	M-3551 M-3551-HF M-642 M-3515* M-3516 M-3541 M-3542 M-3534 M-3552* M-3554 M-3530* M-3547* M-3204 M-3230 M-3247	29.0 30.0 33.0 41.0 20.0 25.0 26.0 27.0 41.0 31.0 41.0 41.0 57.0 58.0 59.0
	OPERATES 2 DOUBLE ACTING CYLINDERS		
	PUMP + MOTOR + RESERVOIR + SOLENOID VALVES	M-3528* M-3529*	41.0 37.0
	OPERATES 1 DOUBLE ACTING AND 1 SINGLE ACTING CYLINDER		
	PUMP + MOTOR + RESERVOIR + MANUAL VALVES	M-500-4W/3W	34.0
	PUMP + MOTOR + RESERVOIR + SOLENOID VALVES	M-683 M-3593*	35.0 41.0

* = Modular

Many other circuits are available. Please contact Monarch direct so we can design a special circuit for your requirements.

Monarch D.C. Hydraulic Power Systems

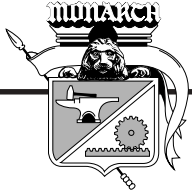

MODEL M-255

Description:

- Pump/Motor Unit
- Check Valve
- Externally Adjustable Relief Valve
- .375 Inch NPT Suction
- 7/16-20 SAE Outlet Port

Popular Option:

- Motor Start Solenoid and Cable

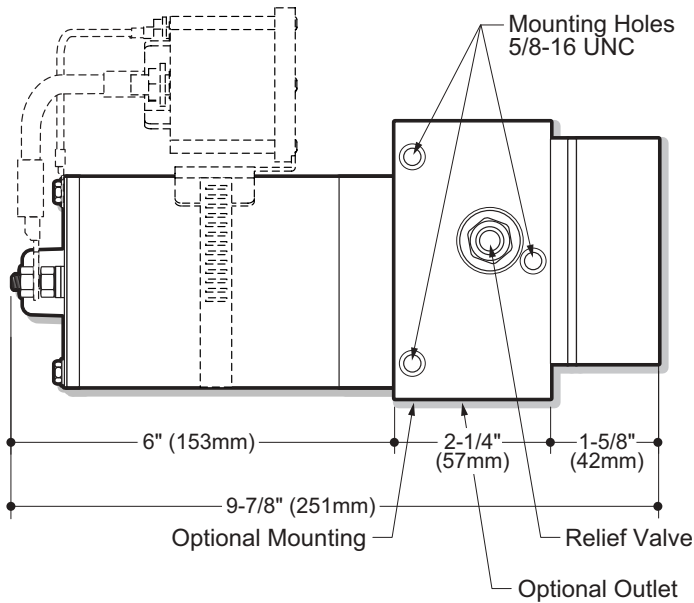
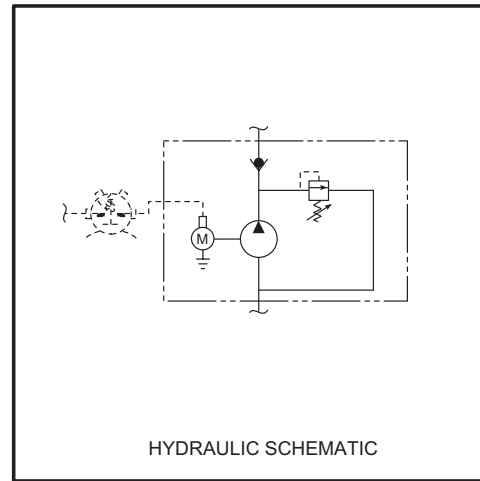

SIDE VIEW

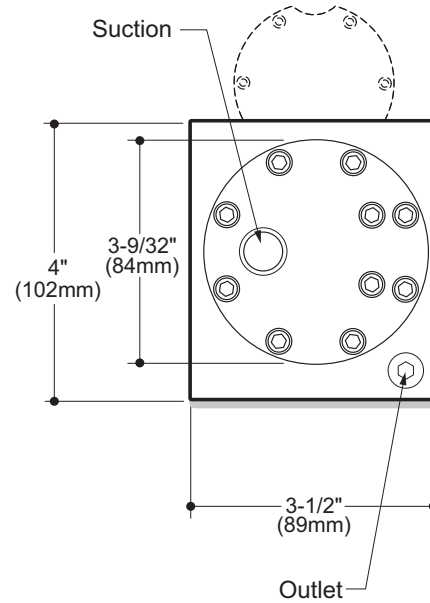

END VIEW

How to Order Your M-255 Mini System

Comprehensive information may be found on the page referenced below each selection category.

Shown as Standard with:				
<i>i</i> -pump (req'd.)	08053	12		
PUMP	MOTOR	VOLTAGE	MOTOR START SWITCH	OPTIONAL ACCESSORIES
Ref. Page 54.0	Ref. Page 61.0		Ref. Page 96.0	Ref. Page 99.0

MODEL M-326

Description:

- Pump Motor Unit
- Check Valve
- Externally Adjustable Relief Valve
- .375 Inch NPT Suction
- #6 SAE Outlet
- .125 Inch NPT Relief Valve Return Port

Popular Option:

- Suction and Outlet on Pump End Plate
- Motor Start Solenoid and Bus Bar

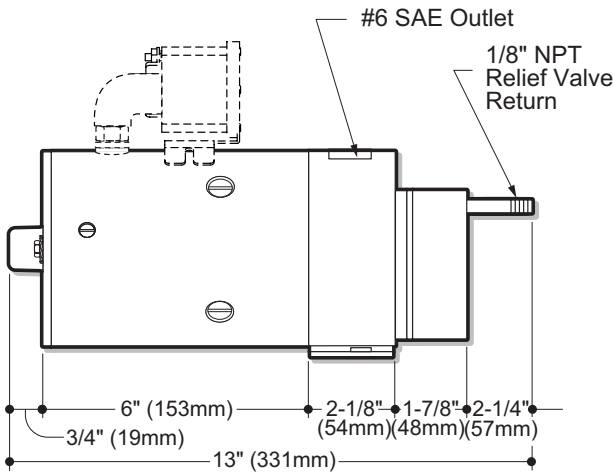
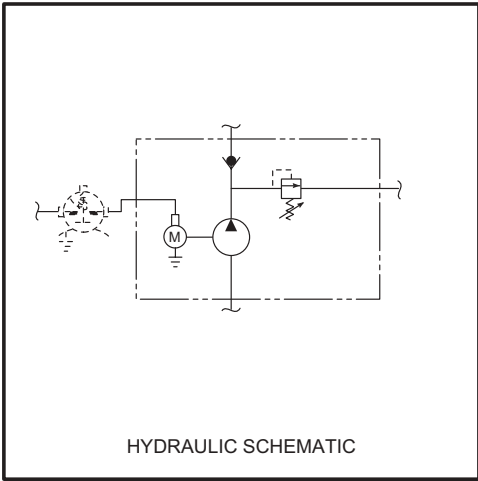

SIDE VIEW

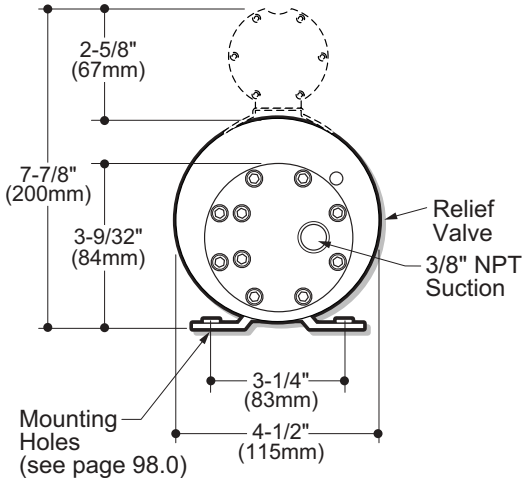

END VIEW

How to Order Your M-326 Dyna-Jack®

Comprehensive information may be found on the page referenced below each selection category.

Shown as Standard with:					
	08111	12		04560	
PUMP	MOTOR	VOLTAGE	MOTOR START SWITCH	MOUNTING BRACKET	OPTIONAL ACCESSORIES
Ref. Page 54.0	Ref. Page 61.0		Ref. Page 96.0	Ref. Page 98.0	Ref. Page 99.0

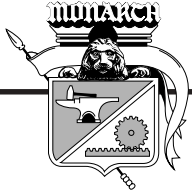

MODEL M-304

Description:

- Pump /Motor Unit/Reservoir Unit
- Check Valve
- Externally Adjustable Relief Valve
- #6 SAE Outlet
- .250 NPT Return
- Horizontal Mounting Standard

Popular Option:

- Vertical Mounting. Motor Up

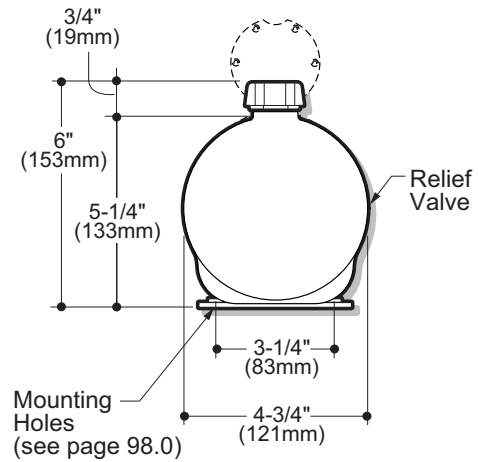
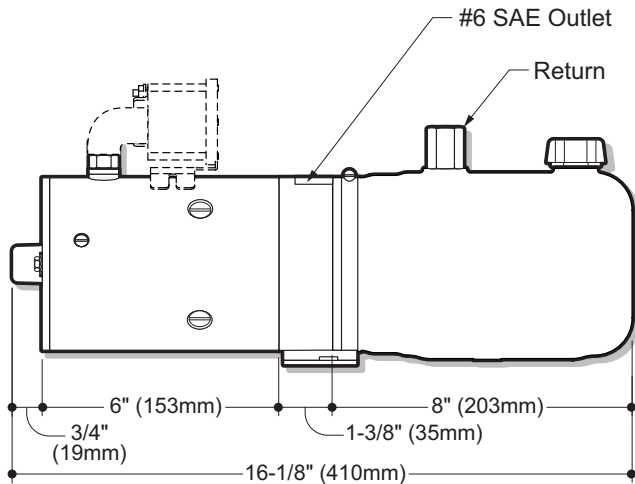
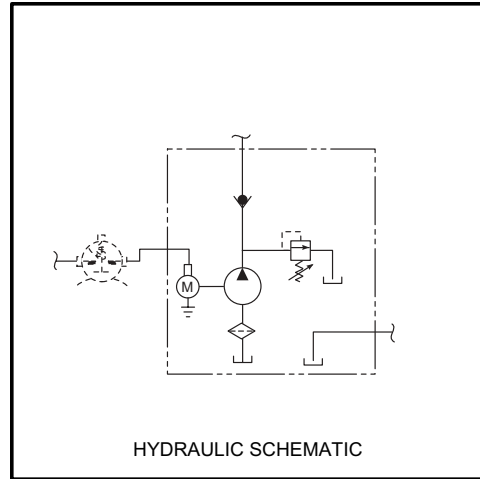

How to Order Your M-304 Dyna-Jack®

Comprehensive information may be found on the page referenced below each selection category.

Shown as Standard with:							
	08111	12	06102		04560	HORIZ	
PUMP	MOTOR	VOLTAGE	RESERVOIR (LENGTH)	MOTOR START SWITCH	MOUNTING BRACKET	MOUNTING POSITION	OPTIONAL ACCESSORIES
Ref. Page 54.0	Ref. Page 61.0		Ref. Page 87.0-93.0	Ref. Page 96.0	Ref. Page 98.0		Ref. Page 99.0

MODEL M-3504

Description:

- Pump/Motor/Reservoir Unit
- Check Valve
- Externally Adjustable Relief Valve
- #6 SAE Outlet
- #6 SAE Return
- Horizontal Mounting Standard

Popular Option:

- Vertical Mounting. Motor Up

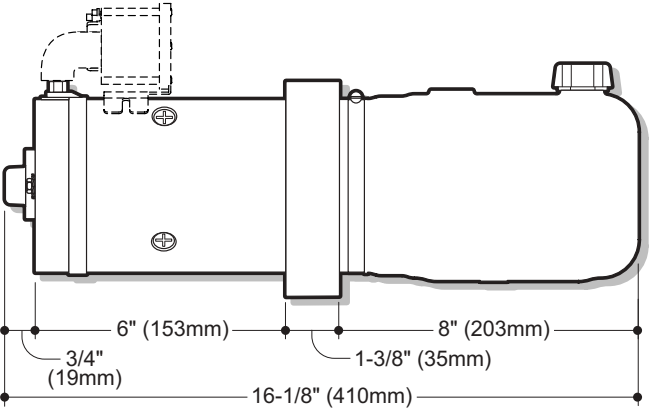
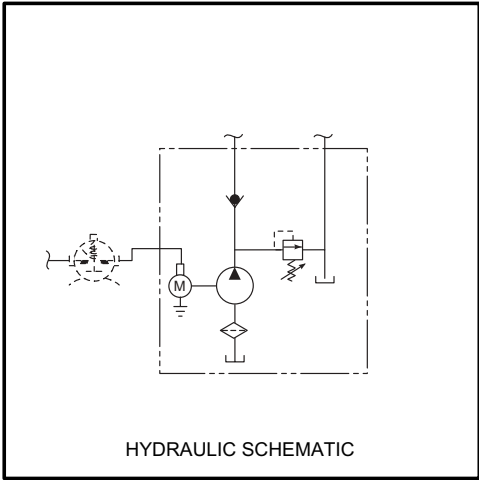

SIDE VIEW

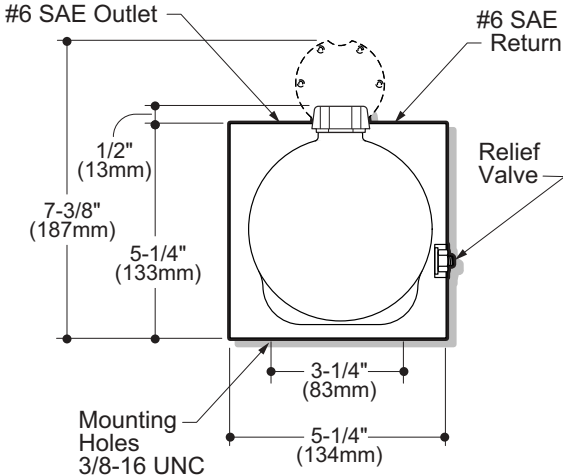

END VIEW

How to Order Your M-3504 Dyna-Jack®

Comprehensive information may be found on the page referenced below each selection category.

Shown as Standard with:						
	08111	12	06102		HORIZ	
PUMP	MOTOR	VOLTAGE	RESERVOIR (LENGTH)	MOTOR START SWITCH	MOUNTING POSITION	OPTIONAL ACCESSORIES
Ref. Page 54.0	Ref. Page 61.0		Ref. Page 87.0-93.0	Ref. Page 96.0		Ref. Page 99.0

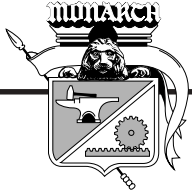

MODEL M-301

Description:

- Pump/Motor/Reservoir Unit
- Manually Operated 2-Way/2-Position Normally Closed Valve With Motor Start Switch
- Check Valve
- Externally Adjustable Relief Valve
- #4 SAE Outlet
- Horizontal Mounting Standard

Popular Option:

- Vertical Mounting. Motor Up

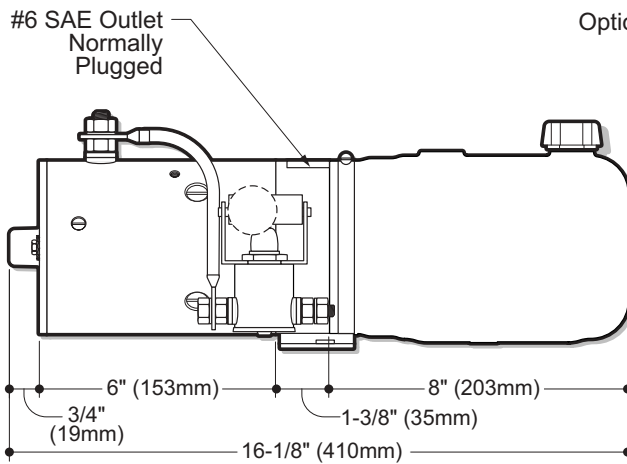
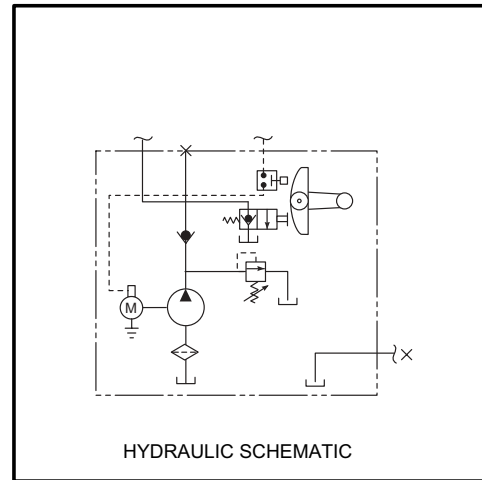

SIDE VIEW

Optional Eye-Bolt

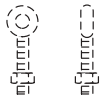

Optional Handle Location

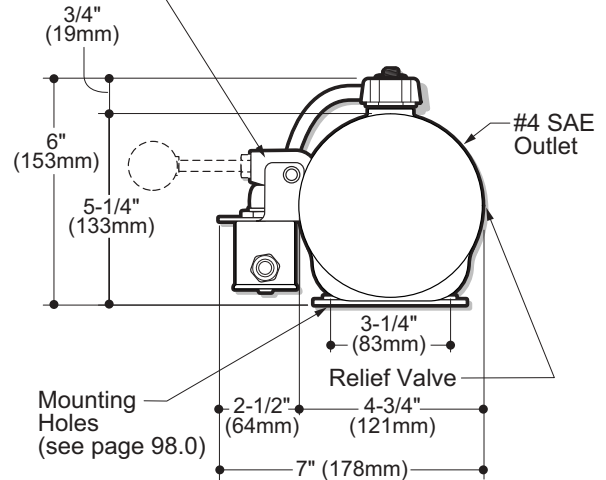

END VIEW

How to Order Your M-301 Dyna-Jack®

Comprehensive information may be found on the page referenced below each selection category.

Shown as Standard with:						
	08111	12	06102	04560	HORIZ	
PUMP	MOTOR	VOLTAGE	RESERVOIR (LENGTH)	MOUNTING BRACKET	MOUNTING POSITION	OPTIONAL ACCESSORIES
Ref. Page 54.0	Ref. Page 61.0		Ref. Page 87.0-93.0	Ref. Page 98.0		Ref. Page 99.0

MODEL M-311

Description:

- Pump/Motor/Reservoir/Valve
- Manually Operated 2-Way/2-Position Normally Closed Valve With Motor Start Switch
- Metered Spool for *Fine Control* of Lowering Speed
- Check Valve
- Externally Adjustable Relief Valve
- #4 SAE Outlets
- Horizontal Mounting Standard

Popular Option:

- Non-Metered Lowering Spool
- Vertical Mounting. Motor Up

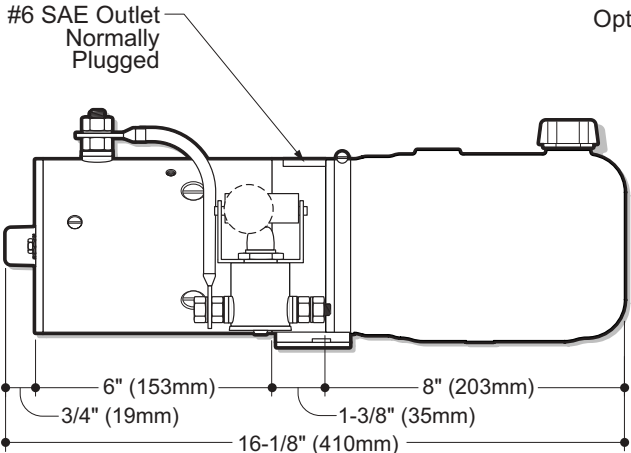
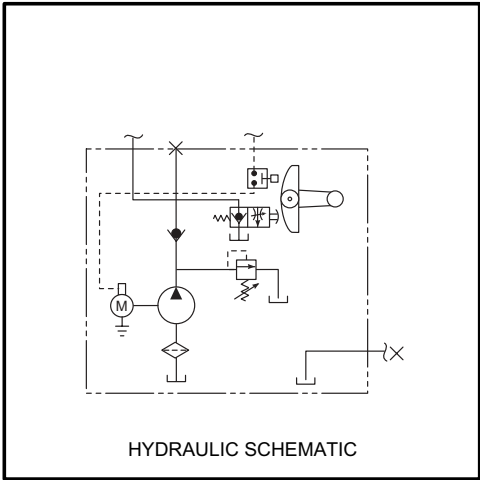

SIDE VIEW

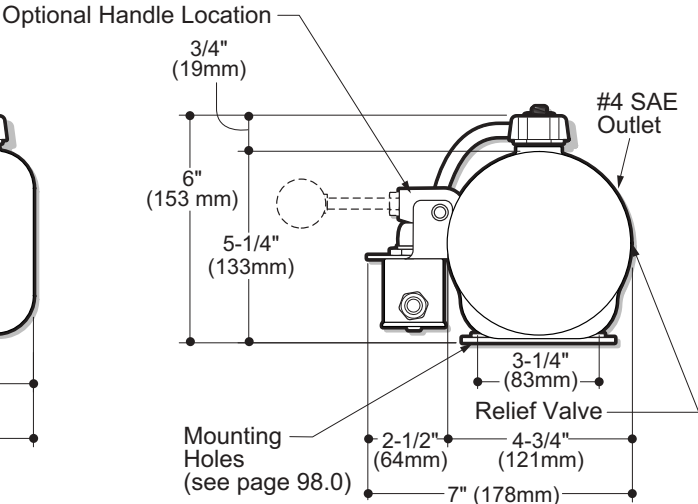

END VIEW

Optional Eye-Bolt



How to Order Your M-311 Dyna-Jack®

Comprehensive information may be found on the page referenced below each selection category.

Shown as Standard with:						
	08111	12	06102	04560	HORIZ	
PUMP	MOTOR	VOLTAGE	RESERVOIR (LENGTH)	MOUNTING BRACKET	MOUNTING POSITION	OPTIONAL ACCESSORIES
Ref. Page 54.0	Ref. Page 61.0		Ref. Page 87.0-93.0	Ref. Page 98.0		Ref. Page 99.0

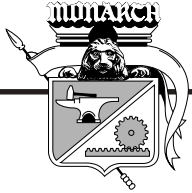

MODEL M-313

Description:

- Pump/Motor/Reservoir/Valve
- Manually Operated 2-Way/2-Position Normally Closed Valve With Motor Start Switch. Valve Handle Travel Is Inline With Motor
- Check Valve
- Externally Adjustable Relief Valve
- #6 SAE Outlet
- Horizontal Mounting Standard

Popular Option:

- Metered Lowering Valve Housing For *Fine Control of Lowering Speed*
- .250 Inch NPT Outlet
- Vertical Mounting. Motor Up

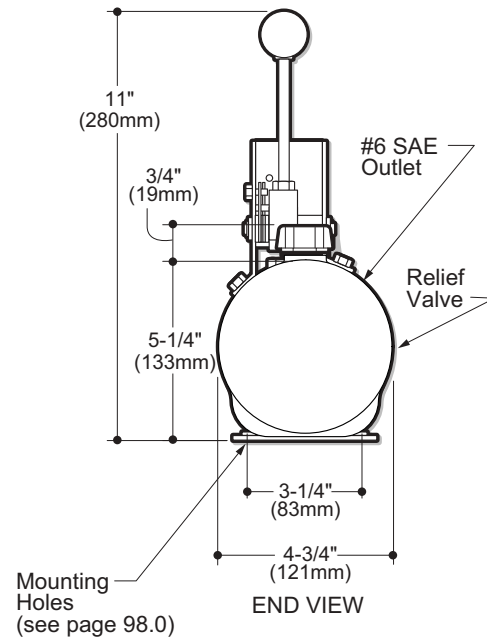
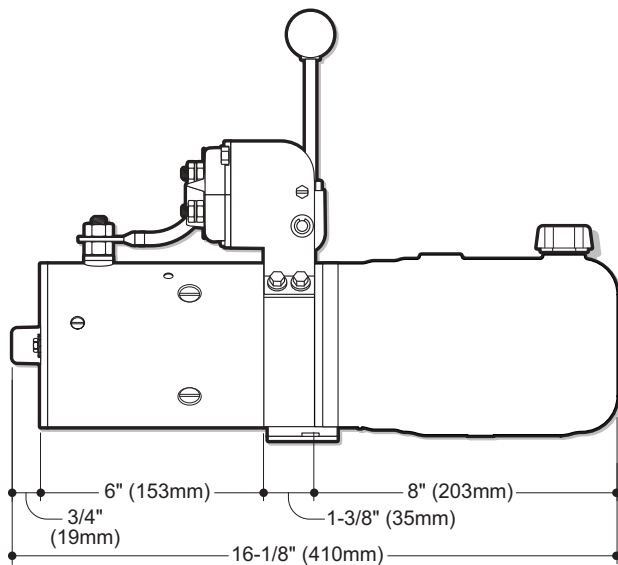
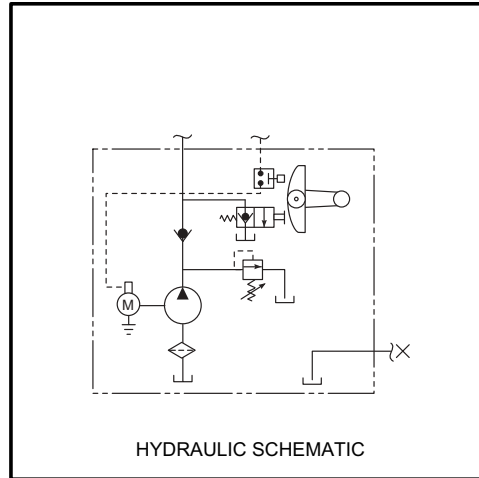

Optional Eye-Bolt



How to Order Your M-313 Dyna-Jack®

Comprehensive information may be found on the page referenced below each selection category.

Shown as Standard with:						
	08111	12	06102	04560	HORIZ	
PUMP	MOTOR	VOLTAGE	RESERVOIR (LENGTH)	MOUNTING BRACKET	MOUNTING POSITION	OPTIONAL ACCESSORIES
Ref. Page 54.0	Ref. Page 61.0		Ref. Page 87.0-93.0	Ref. Page 98.0		Ref. Page 99.0

MODEL M-721

Description:

- Pump/Motor/Reservoir/Valve
- Manually Operated 2-Way/2-Position Normally Closed Valve With Motor Start Switch
- Externally Adjustable Relief Valve
- .250 Inch NPT and .375 Inch NPT Outlets
- Vertical Mounting Only
- Includes Protective Steel Cover

Typical Application

- Controls Discharge Chute on Cement Delivery Truck

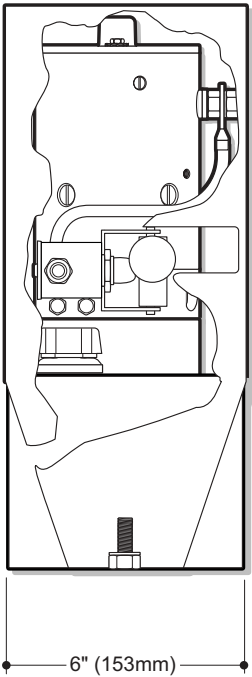
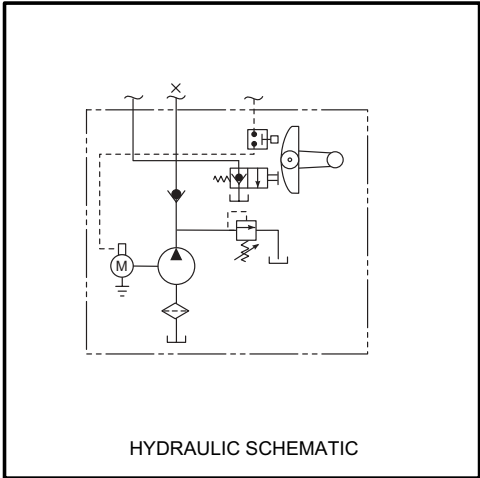

SIDE VIEW

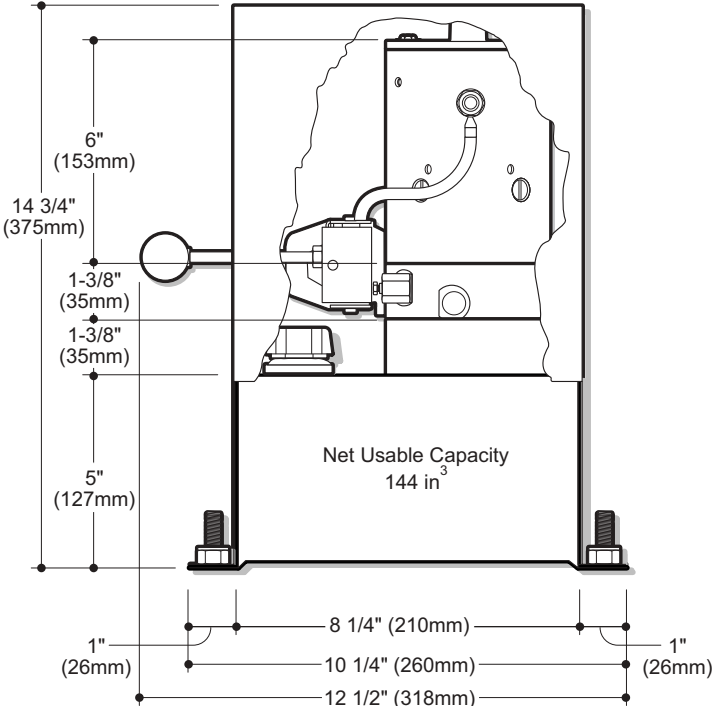

END VIEW

How to Order Your M-721 Dyna-Chute®

Comprehensive information may be found on the page referenced below each selection category.

Shown as Standard with:				
12171 - 270	08111	12	Vert	
PUMP	MOTOR	VOLTAGE	MOUNTING POSITION	OPTIONAL ACCESSORIES
Ref. Page 54.0	Ref. Page 61.0			Ref. Page 99.0



MODEL M-258

Description:

- Pump/Motor/Reservoir/Valve
- 2-Way/2-Position Normally Closed Solenoid Operated Lowering Valve
- Cartridge Style Pressure Compensated Lowering Valve
- Externally Adjustable Relief Valve
- Outlet Port Options:
- Check Valve Port: 7/16-20 SAE O-Ring or Face Port: 7/16-20 SAE O-Ring
- Horizontal Mounting Standard.

Popular Feature:

- Solenoid Lowering Valve is Recessed Into Base and Protected from Abuse

Popular Option:

- Hand Pump Manifold Directly to Base. (Shown in Dashed Lines)
- .250 Inch NPT Outlet
- Control Box and Cord
- Vertical Mounting. Motor Up.

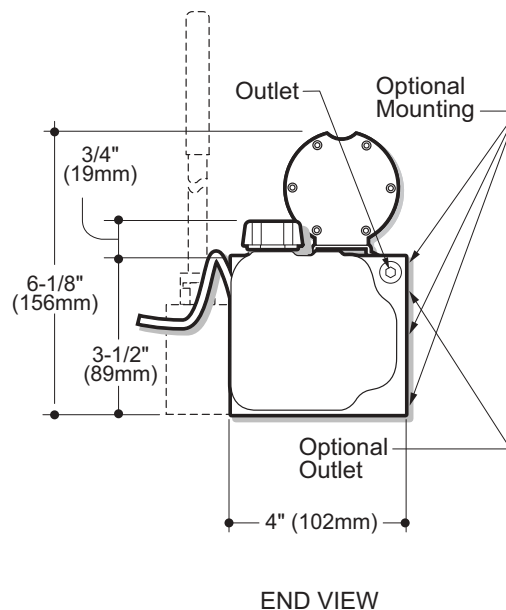
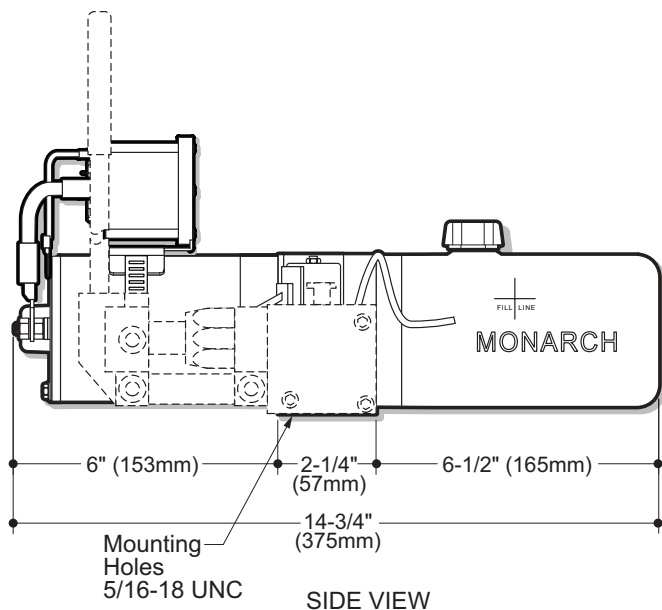
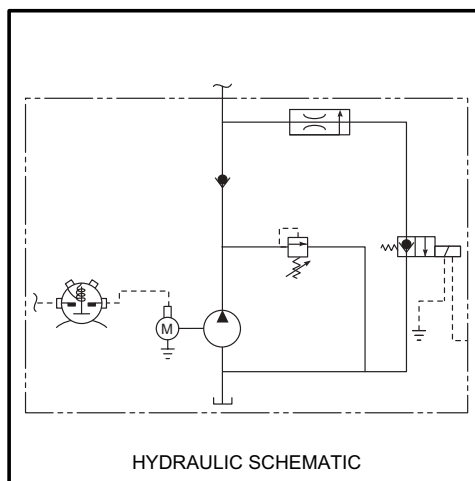

How to Order Your M-258 Mini System

Comprehensive information may be found on the page referenced below each selection category.

Shown as Standard with:								
	08053	12	06230	17757	HORIZ			
PUMP	MOTOR	VOLTAGE	RESERVOIR (LENGTH)	MOTOR START SWITCH	MOUNTING POSITION	CONTROL STATION	OPTIONAL HAND PUMP	OPTIONAL ACCESSORIES
Ref. Page 54.0	Ref. Page 61.0		Ref. Page 87.0-93.0	Ref. Page 96.0		Ref. Page 97.0	Ref. Page 100.0	Ref. Page 99.0

MODEL M-259

Description:

- Pump/Motor/Reservoir/Valve
- Check Valve
- 2-Way/2-Position Normally Closed Solenoid Operated Lowering Valve
- Externally Adjustable Relief Valve
- Outlet Port Options:
Check Valve Port: 7/16-20 SAE O-Ring or
Face Port: 7/16-20 SAE O-Ring
- Horizontal Mounting Standard

Popular Feature:

- Solenoid Lowering Valve is Recessed Into Base and Protected from Abuse

Popular Option:

- Hand Pump Manifold Directly to Base. (Shown in Dashed Lines)
- .250 Inch NPT Outlet
- Control Box and Cord
- Vertical Mounting. Motor Up

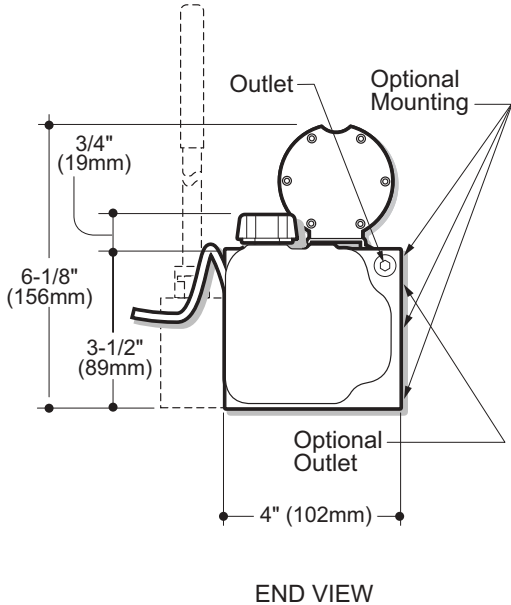
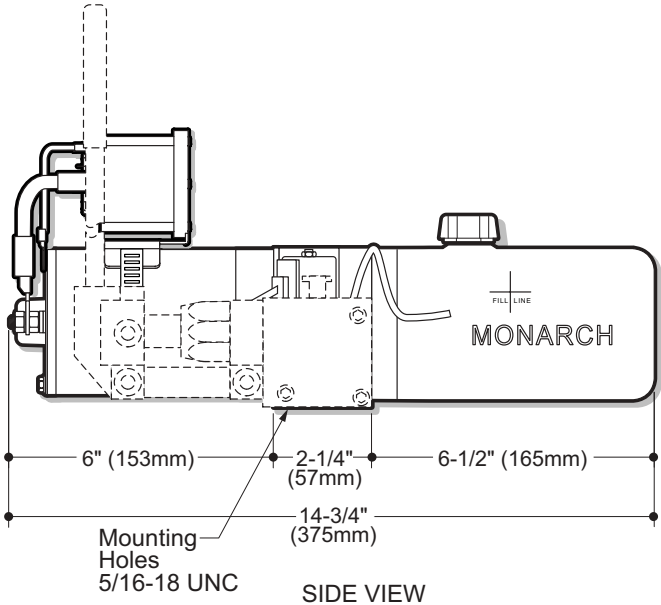
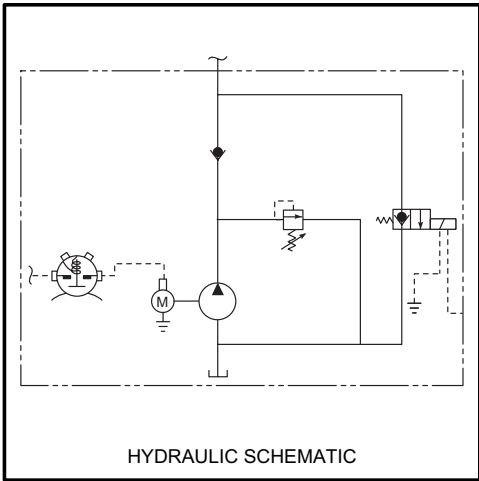

How to Order Your M-259 Mini System

Comprehensive information may be found on the page referenced below each selection category.

Shown as Standard with:								
	08053	12	06230	17757	HORIZ			
PUMP	MOTOR	VOLTAGE	RESERVOIR (LENGTH)	MOTOR START SWITCH	MOUNTING POSITION	CONTROL STATION	OPTIONAL HAND PUMP	OPTIONAL ACCESSORIES
Ref. Page 54.0	Ref. Page 61.0		Ref. Page 87.0-93.0	Ref. Page 96.0		Ref. Page 97.0	Ref. Page 100.0	Ref. Page 99.0

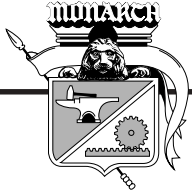

MODEL M-319

Description:

- Pump/Motor/Reservoir/Valve
- Check Valve
- 2-Way/2-Position Normally Closed Solenoid Operated Lowering Valve
- Externally Adjustable Relief Valve
- #6 SAE Outlet
- Horizontal Mounting Standard

Popular Options:

- Control Box and Cord
- Vertical Mounting. Motor Up

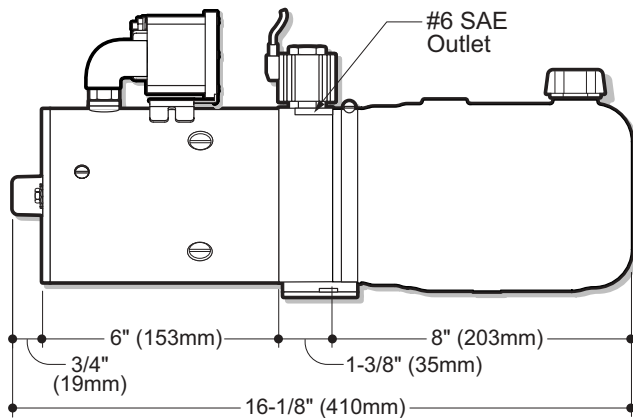
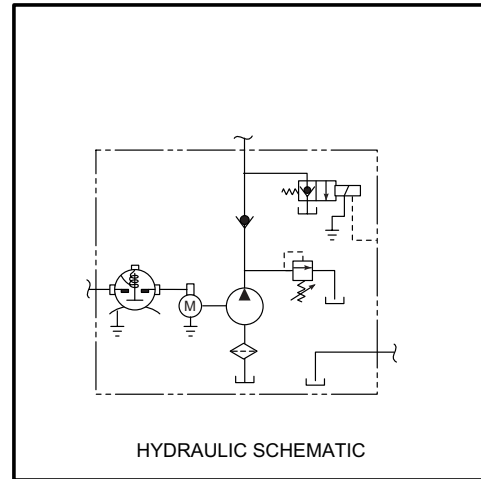

SIDE VIEW

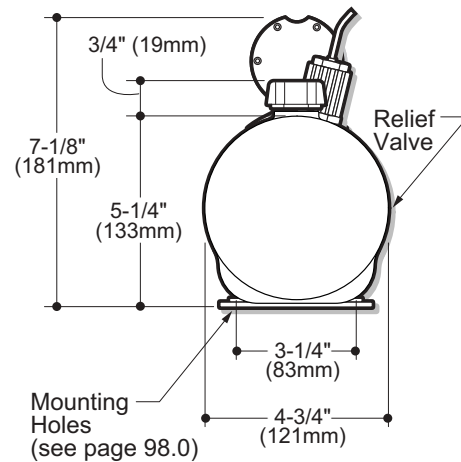

END VIEW

How to Order Your M-319 Dyna-Jack®

Comprehensive information may be found on the page referenced below each selection category.

Shown as Standard with:								
	08111	12	06102	17757	04560	Horiz.		
PUMP	MOTOR	VOLTAGE	RESERVOIR (LENGTH)	MOTOR START SWITCH	MOUNTING BRACKET	MOUNTING POSITION	OPTIONAL ACCESSORIES	CONTROL STATION
Ref. Page 54.0	Ref. Page 61.0		Ref. Page 87.0-93.0	Ref. Page 96.0	Ref. Page 98.0		Ref. Page 99.0	Ref. Page 97.0

MODEL M-3519

Description:

- Pump/Motor/Reservoir/Valve
- Check Valve
- Externally Adjustable Relief Valve
- 2-Way/2-Position Normally Closed Solenoid Cartridge Valve
- #6 SAE Outlet
- Horizontal Mounting Standard

Popular Options:

- Control Box and Cord
- Vertical Mounting. Motor Up
- Pressure Compensated (Cartridge Style) Orifice On Lowering Circuit*
- Manual Override*
- Hand Pump Manifold Mounts Directly to Base*

* Option Requires Power Unit Dimensions and Features Different Than Those Shown Below

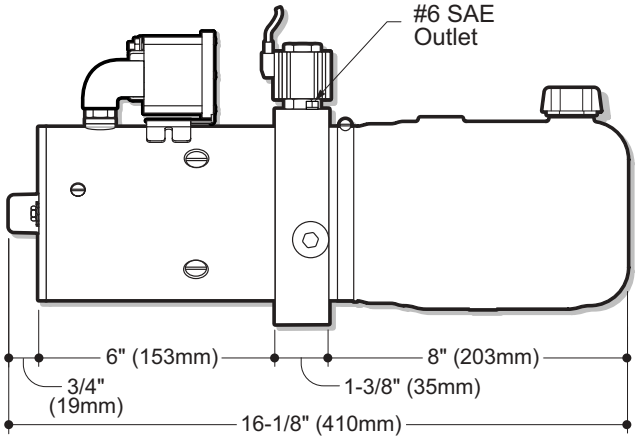
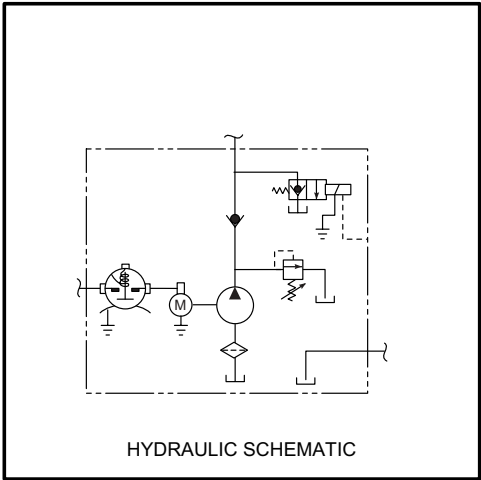

SIDE VIEW

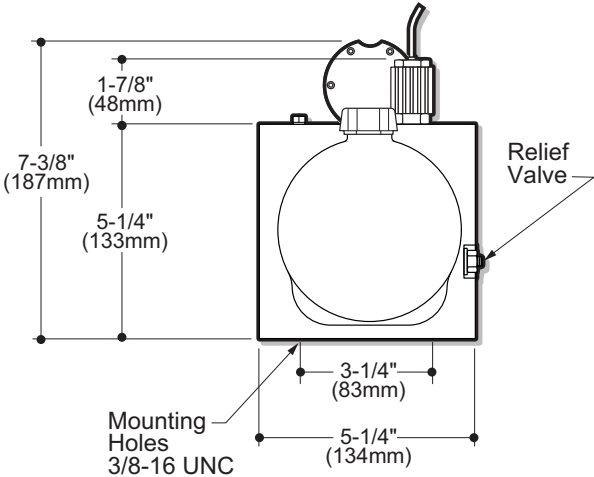

END VIEW

How to Order Your M-3519 Dyna-Jack®

Comprehensive information may be found on the page referenced below each selection category.

Shown as Standard with:							
	08111	12	06102	17757	Horiz.		
PUMP	MOTOR	VOLTAGE	RESERVOIR (LENGTH)	MOTOR START SWITCH	MOUNTING POSITION	OPTIONAL ACCESSORIES	CONTROL STATION
Ref. Page 54.0	Ref. Page 61.0		Ref. Page 87.0-93.0	Ref. Page 96.0		Ref. Page 99.0	Ref. Page 97.0

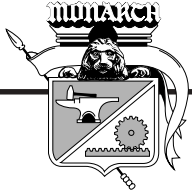

MODEL M-3519-HF (High Flow)

Description:

- Pump/Motor/Reservoir/High Flow Lowering Valve
- Pressure Drop Thru Base <100 PSI (6.9 Bar) at 8 GPM (30 LPM) With Needle Valve Completely Open for Fast Lowering Speed
- Check Valve
- Externally Adjustable Relief Valve
- 2 Way/2 Position Normally Closed Solenoid Cartridge Valve
- Horizontal Mounting Standard
- Manual Needle Valve for Adjusting Lowering Speed With Tamper Resistant Locking Cap
- #8 SAE Outlet

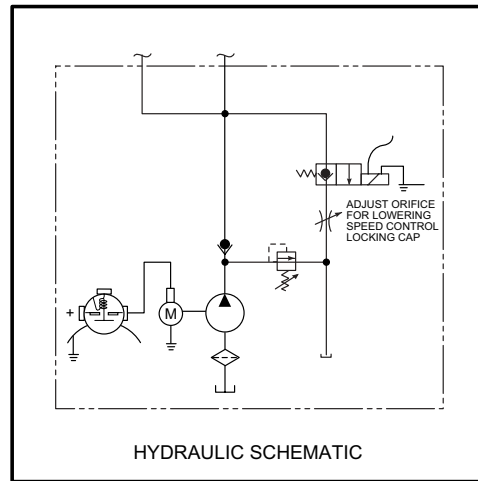

Popular Options

- Control Box and Cord
- Vertical Mounting, Motor Up

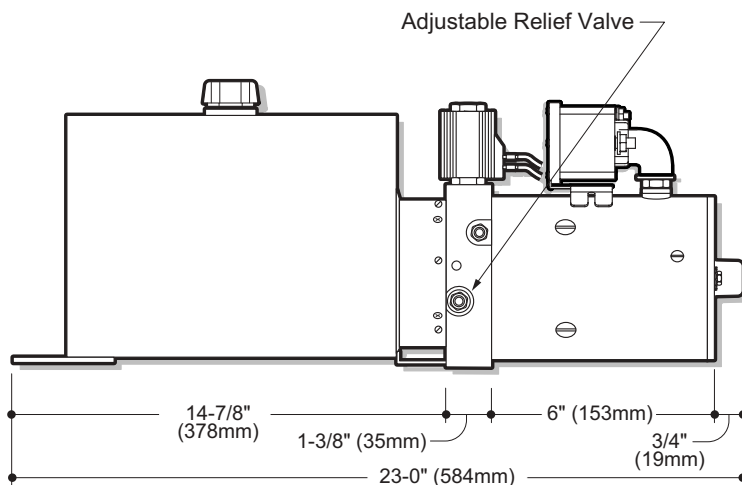

SIDE VIEW

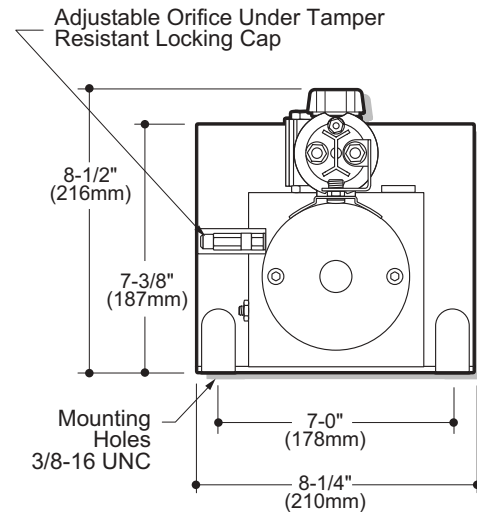

END VIEW

How to Order Your M-3519-HF Dyna-Jack®

Comprehensive information may be found on the page referenced below each selection category.

Shown as Standard with:							
	08111	12	06328	17757	Horiz.		
PUMP	MOTOR	VOLTAGE	RESERVOIR (LENGTH)	MOTOR START SWITCH	MOUNTING POSITION	OPTIONAL ACCESSORIES	CONTROL STATION
Ref. Page 54.0	Ref. Page 61.0		Ref. Page 87.0-93.0	Ref. Page 96.0		Ref. Page 99.0	Ref. Page 97.0

MODEL M-3515

Description:

- Pump/Motor/Reservoir/Valve
- Check Valve in "P" Port
- Externally Adjustable Relief Valve
- D03 Solenoid Valve
- #6 SAE Outlets
- Horizontal Mounting Standard

Popular Options:

- Control Box and Cord
- Vertical Mounting. Motor Up
- Large Selection of D03/CETOP Valves and Accessories

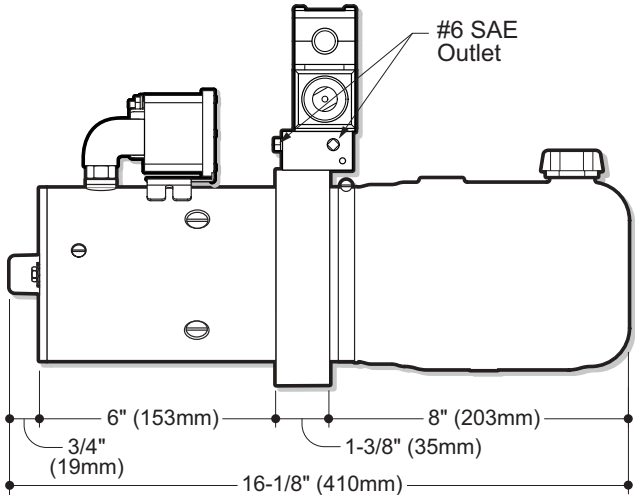
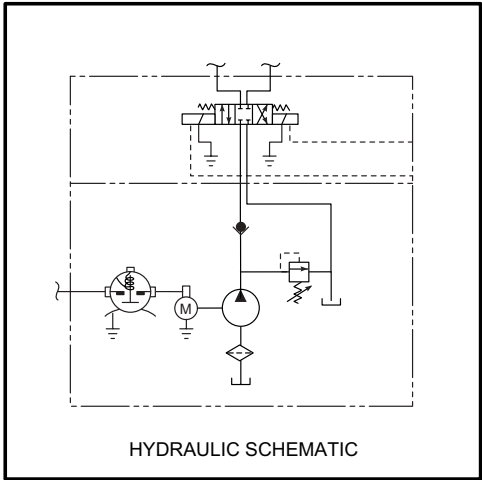

SIDE VIEW

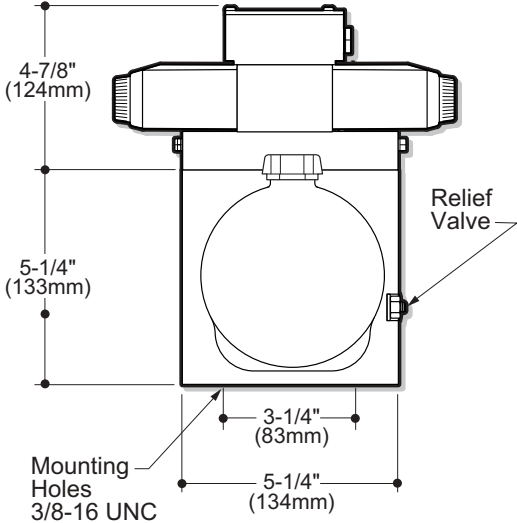

END VIEW

How to Order Your M-3515 Dyna-Jack®

Comprehensive information may be found on the page referenced below each selection category.

Shown as Standard with:							
	08111	12	06102	17757	Horiz.		
PUMP	MOTOR	VOLTAGE	RESERVOIR (LENGTH)	MOTOR START SWITCH	MOUNTING POSITION	OPTIONAL ACCESSORIES	CONTROL STATION
Ref. Page 54.0	Ref. Page 61.0		Ref. Page 87.0-93.0	Ref. Page 96.0		Ref. Page 99.0	Ref. Page 97.0



MODEL M-3516

Description:

- Pump/Motor/Reservoir
- Check Valve in "P" Port
- Externally Adjustable Relief Valve
- #6 SAE Outlets
- Horizontal Mounting Standard

Popular Options:

- Control Box and Cord
- Vertical Mounting. Motor Up

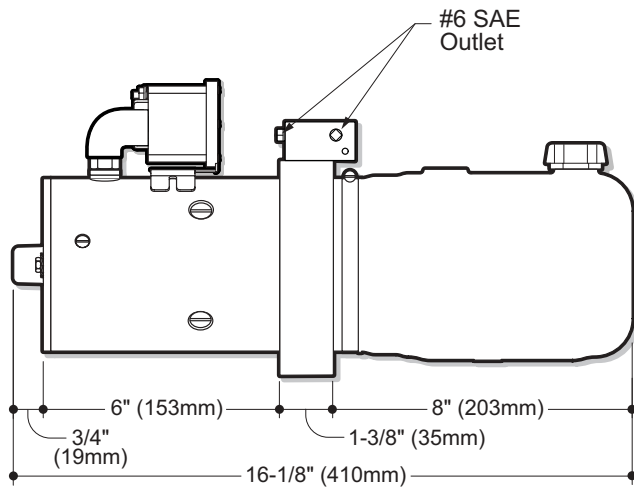
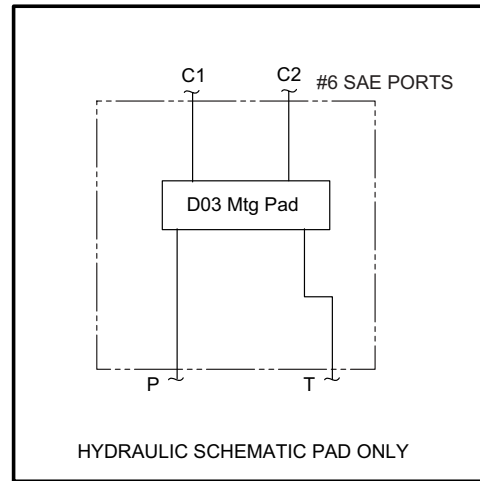

SIDE VIEW

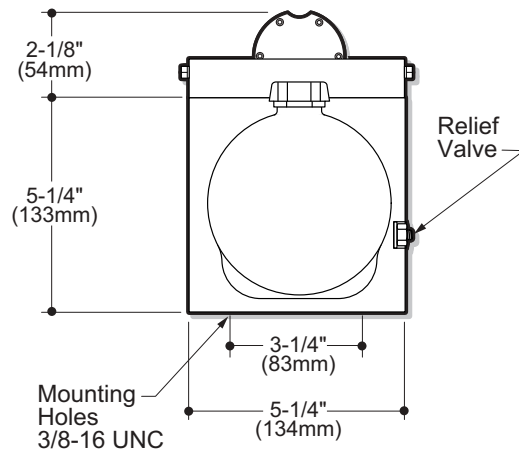

END VIEW

How to Order Your M-3516 Dyna-Jack®

Comprehensive information may be found on the page referenced below each selection category.

Shown as Standard with:							
	08111	12	06102	17757	Horiz.		
PUMP	MOTOR	VOLTAGE	RESERVOIR (LENGTH)	MOTOR START SWITCH	MOUNTING POSITION	OPTIONAL ACCESSORIES	CONTROL STATION
Ref. Page 54.0	Ref. Page 61.0		Ref. Page 87.0-93.0	Ref. Page 96.0		Ref. Page 99.0	Ref. Page 97.0

MODEL M-314

Description:

- Pump/Motor/Reservoir/Valve
- Check Valve
- 2-Way/2-Position Normally Closed Solenoid Operated Lowering Valve and Return Filter Installed in Reservoir
- Manual Override for Emergency Lowering During Power Loss
- Externally Adjustable Relief Valve
- #6 SAE Outlets
- Horizontal Mounting Standard

Popular Option:

- Control Box and Cord
- Vertical Mounting. Motor Up

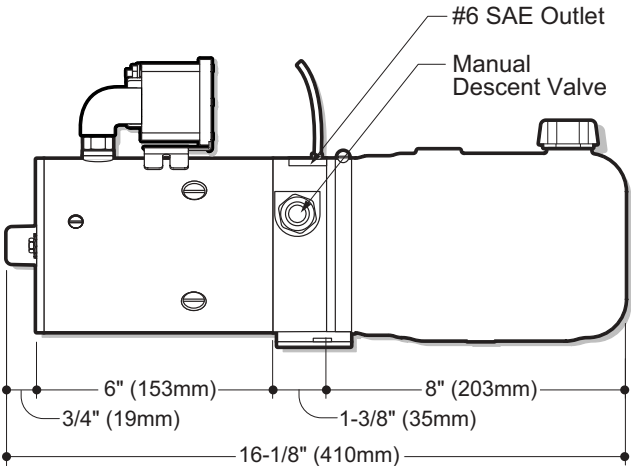
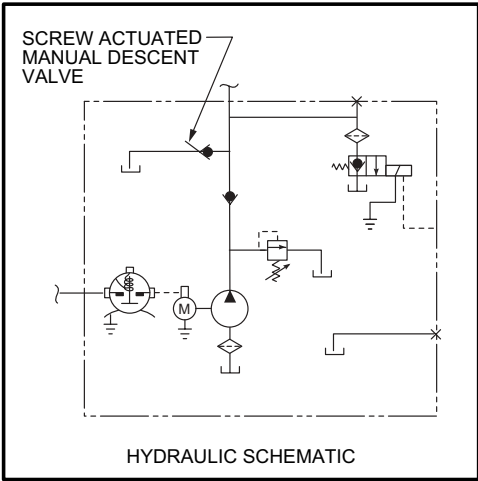

SIDE VIEW

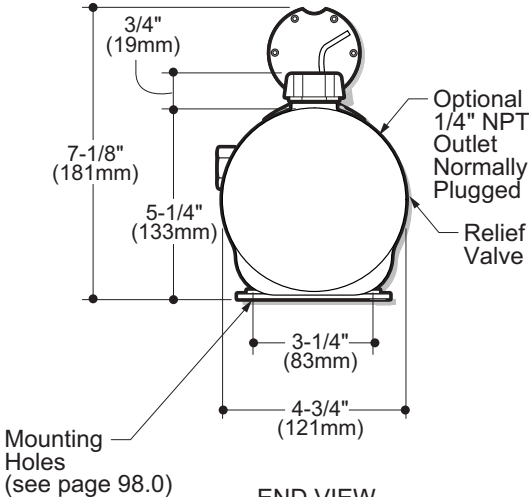

END VIEW

How to Order Your M-314 Dyna-Jack®

Comprehensive information may be found on the page referenced below each selection category.

Shown as Standard with:									
	08111	12	06102		17757	04560	Horiz.		
PUMP	MOTOR	VOLTAGE	RESERVOIR (LENGTH)	CARTRIDGE VALVE	MOTOR START SWITCH	MOUNTING BRACKET	MOUNTING POSITION	OPTIONAL ACCESSORIES	CONTROL STATION
Ref. Page 54.0	Ref. Page 61.0		Ref. Page 87.0-93.0	Ref. Page 94.0-95.0	Ref. Page 96.0	Ref. Page 98.0		Ref. Page 99.0	Ref. Page 97.0



MODEL M-303

Description:

- Pump/Motor/Reservoir/Valve
- Check Valve
- 2-Way/2-Position Normally Closed Solenoid Operated Lowering Valve and Return Filter Installed in Reservoir
- Cable
- Manual Override for Emergency Lowering During Power Loss
- Externally Adjustable Relief Valve
- #6 SAE Outlets
- Horizontal Mounting Standard

Popular Option:

- Vertical Mounting, Motor Up
- Control Box

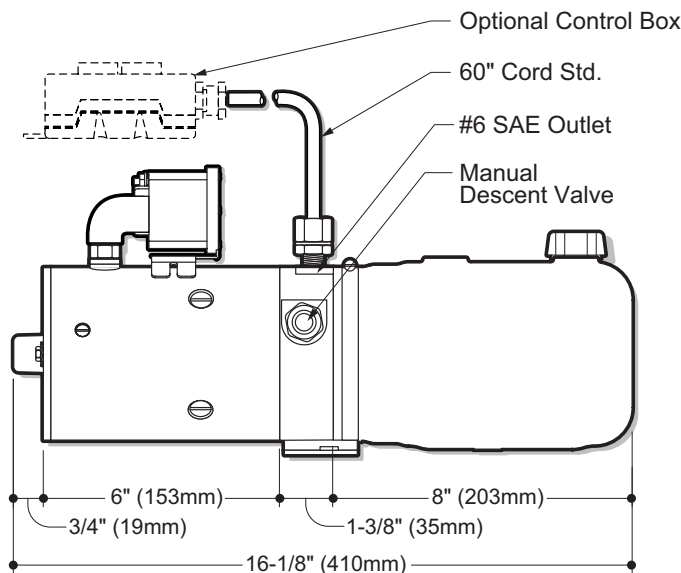
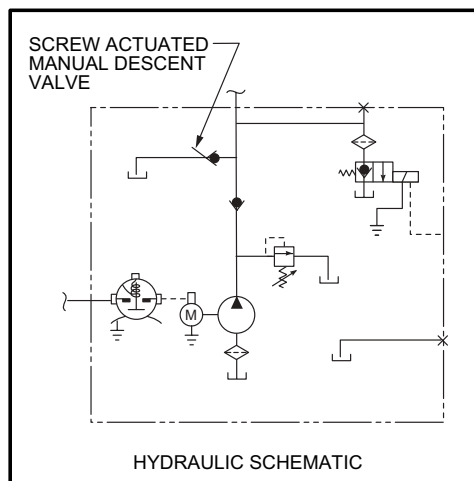

SIDE VIEW

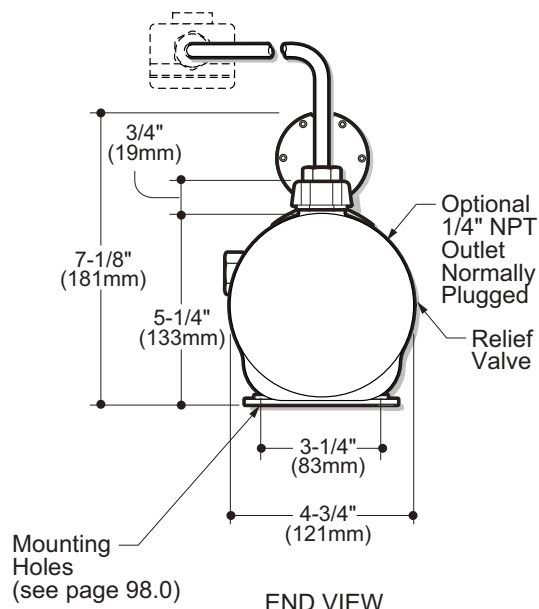

END VIEW

How to Order Your M-303 Dyna-Jack®

Comprehensive information may be found on the page referenced below each selection category.

Shown as Standard with:									
	08111	12	06102		17757	04560	Horiz.		
PUMP	MOTOR	VOLTAGE	RESERVOIR (LENGTH)	CARTRIDGE VALVE	MOTOR START SWITCH	MOUNTING BRACKET	MOUNTING POSITION	OPTIONAL ACCESSORIES	CONTROL STATION
Ref. Page 54.0	Ref. Page 61.0		Ref. Page 87.0-93.0	Ref. Page 94.0-95.0	Ref. Page 96.0	Ref. Page 98.0		Ref. Page 99.0	Ref. Page 97.0

MODEL M-719

Description:

- Pump/Motor/Reservoir/Valve
- Check Valve
- 2-Way/2-Position Normally Closed Solenoid Operated Lowering Valve
- Externally Adjustable Relief Valve
- .375 Inch NPT Outlet
- Fixed Orifice in Lowering Circuit. Externally Cleanable
- Vertical Mounting
- Includes Protective Steel Cover

Popular Options:

- Control Box and Cord

Typical Application:

- Control Discharge Chute on Cement Delivery Truck

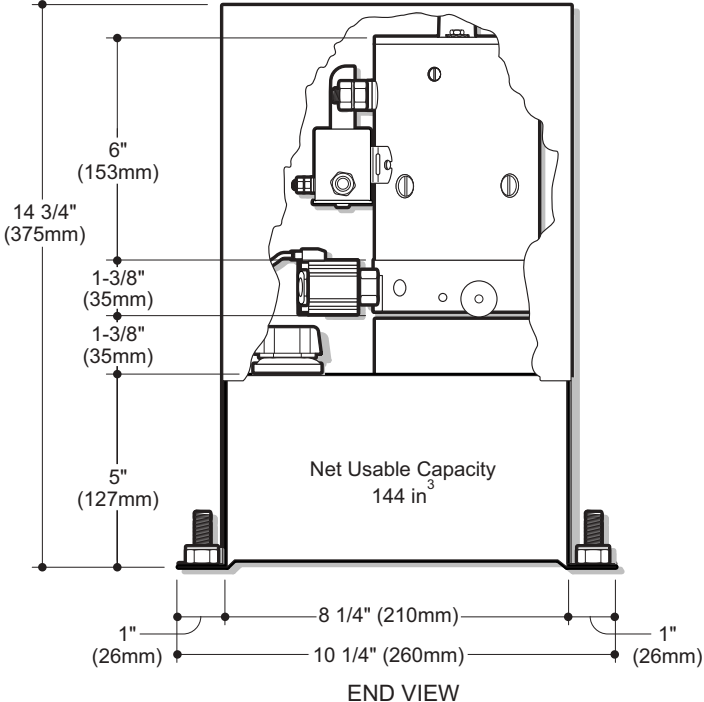
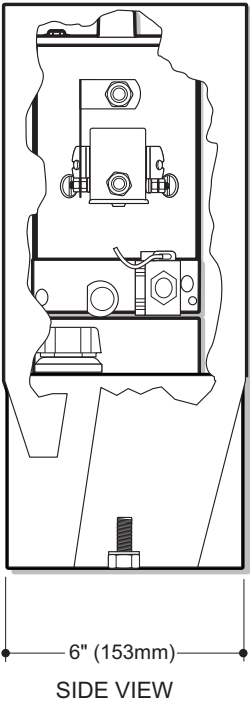
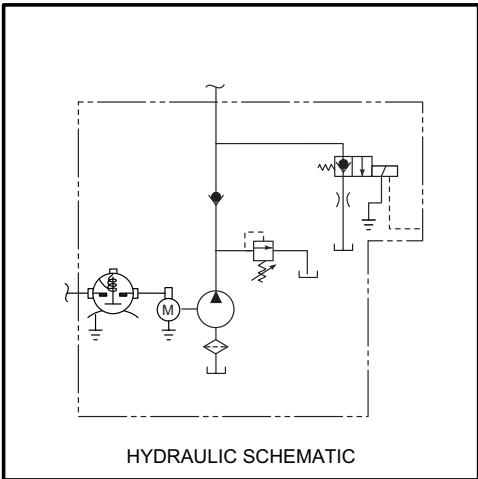

How to Order Your M-719 Dyna-Chute®

Comprehensive information may be found on the page referenced below each selection category.

Shown as Standard with:						
12171 - 270	08111	12	06385	04560	VERT	
PUMP	MOTOR	VOLTAGE	RESERVOIR (LENGTH)	CONTROL STATION	MOUNTING POSITION	OPTIONAL ACCESSORIES
Ref. Page 54.0	Ref. Page 61.0		Ref. Page 87.0-93.0	Ref. Page 97.0		Ref. Page 99.0

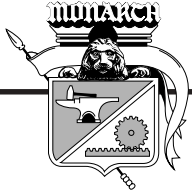

MODEL M-310

Description:

- Pump/Motor/Reservoir/Valve
- Check Valve
- 4-Way Manually Operated Valve With Cam Actuated Motor Start Switch
- Externally Adjustable Relief Valve
- .250 Inch NPT Outlets
- Horizontal Mounting Standard

Popular Options:

- Orifice For Controlling Pressure on A and/or B Ports Available
- Vertical Mounting. Motor Up
- #4 SAE Outlets

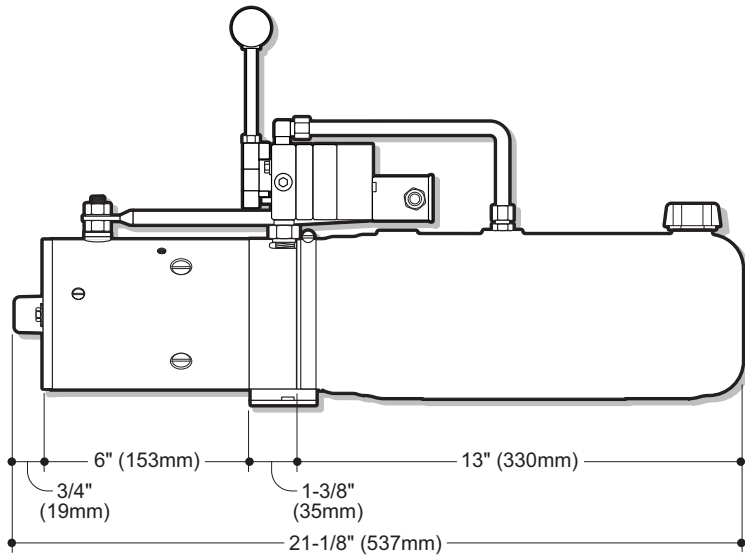
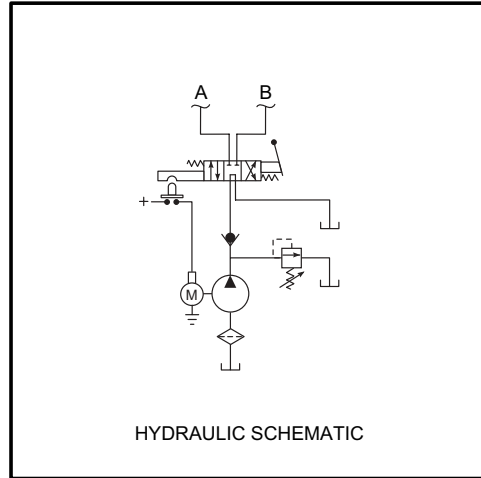

SIDE VIEW

Optional Eye-Bolt

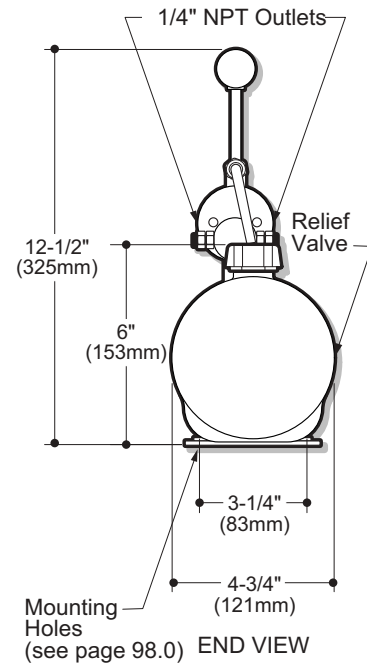

END VIEW

How to Order Your M-310 Dyna-Jack®

Comprehensive information may be found on the page referenced below each selection category.

Shown as Standard with:						
	08111	12	06105	04560	HORIZ	
PUMP	MOTOR	VOLTAGE	RESERVOIR (LENGTH)	MOUNTING BRACKET	MOUNTING POSITION	OPTIONAL ACCESSORIES
Ref. Page 54.0	Ref. Page 61.0		Ref. Page 87.0-93.0	Ref. Page 98.0		Ref. Page 99.0

MODEL M-3541

Description:

- Pump/Motor/Reservoir/Valve
- Check Valve
- Externally Adjustable Relief Valve
- 1 x 4-Way/2-Position Solenoid Cartridge Valve Located in the Base
- #6 SAE Outlets
- Horizontal Mounting Standard

Popular Options:

- Control Box and Cord
- Vertical Mounting, Motor Up

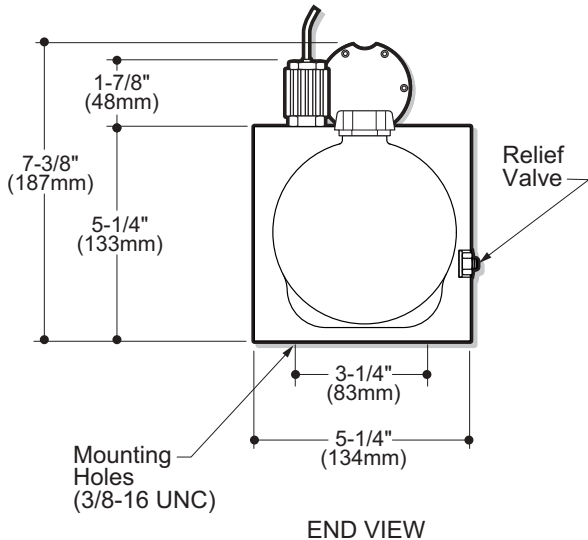
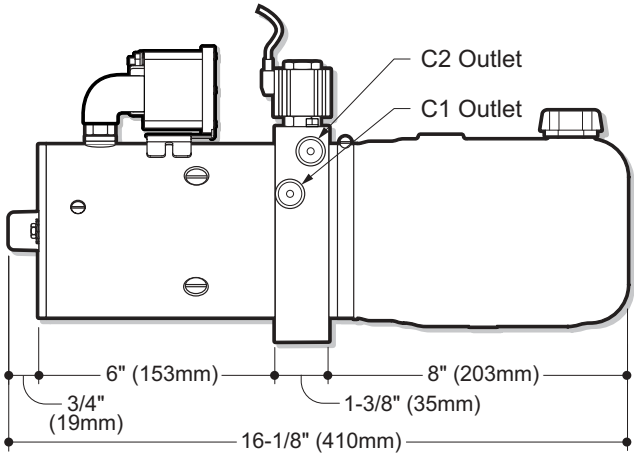
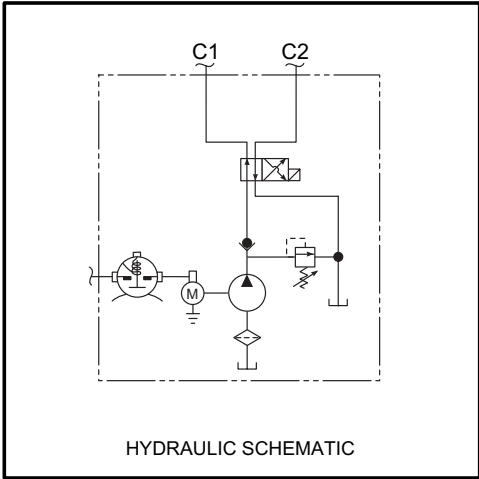

How to Order Your M-3541 Dyna-Jack®

Comprehensive information may be found on the page referenced below each selection category.

Shown as Standard with:							
	08111	12	06102	17757	Horiz.		
PUMP	MOTOR	VOLTAGE	RESERVOIR (LENGTH)	MOTOR START SWITCH	MOUNTING POSITION	OPTIONAL ACCESSORIES	CONTROL STATION
Ref. Page 54.0	Ref. Page 61.0		Ref. Page 87.0-93.0	Ref. Page 96.0		Ref. Page 99.0	Ref. Page 97.0



MODEL M-3542

Description:

- Pump/Motor/Reservoir/Valve
- Check Valve
- Externally Adjustable Relief Valve
- 1 x 4-Way/2-Position Solenoid Cartridge Valve Located Externally. Manifolder Directly To Unit
- C1 Port Positively Checked
- Externally Adjustable Relief Valve in C2 Port
- #6 SAE Outlets
- Horizontal Mounting Standard

Popular Options:

- Pressure Compensated (Cartridge Style) Flow Control In C1 Port
- Control Box and Cord
- Vertical Mounting. Motor Up

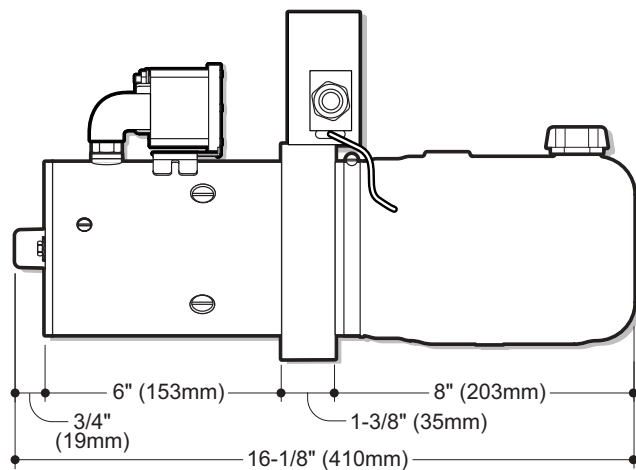
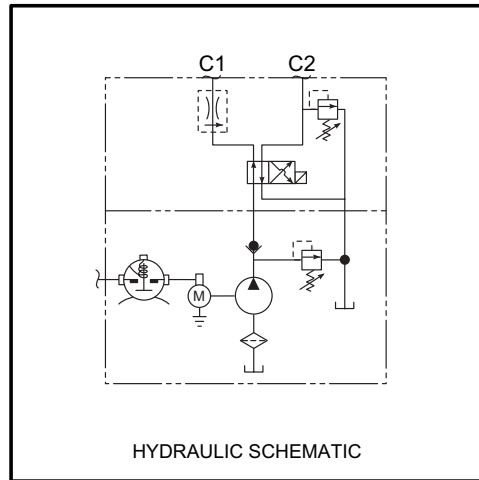

SIDE VIEW

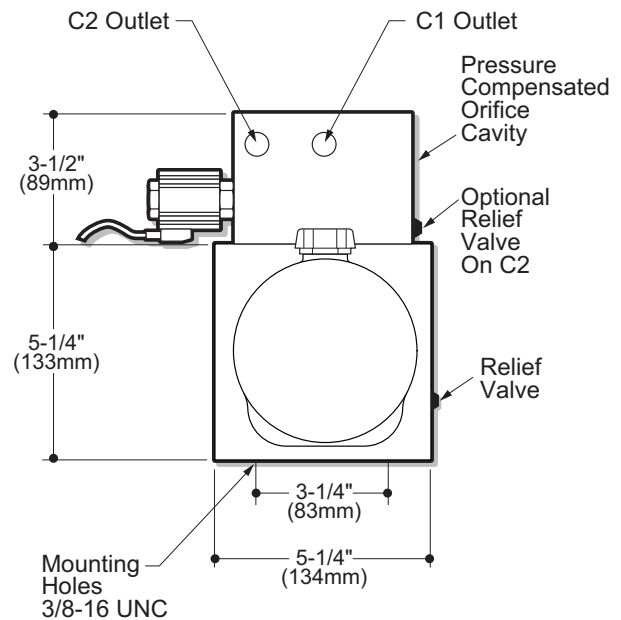

END VIEW

How to Order Your M-3542 Dyna-Jack®

Comprehensive information may be found on the page referenced below each selection category.

Shown as Standard with:							
	08111	12	06102	17757	Horiz.		
PUMP	MOTOR	VOLTAGE	RESERVOIR (LENGTH)	MOTOR START SWITCH	MOUNTING POSITION	OPTIONAL ACCESSORIES	CONTROL STATION
Ref. Page 54.0	Ref. Page 61.0		Ref. Page 87.0-93.0	Ref. Page 96.0		Ref. Page 99.0	Ref. Page 97.0

MODEL M-3534

Hydraulic Power Unit for Operating Single Slide Out Room

Description:

- Compact
- Room Held Safely In Place At All Times
- Accepts Monarch 3" and 4.5" D.C. Motors
- Accepts All Monarch "M" Series Pumps and Reservoirs
- Consult Monarch D.C. Master Catalog for Performance Data and Other Options

Popular Options:

- Hand Pump and Manual Override Controls Slide Out In Case of Electrical Failure

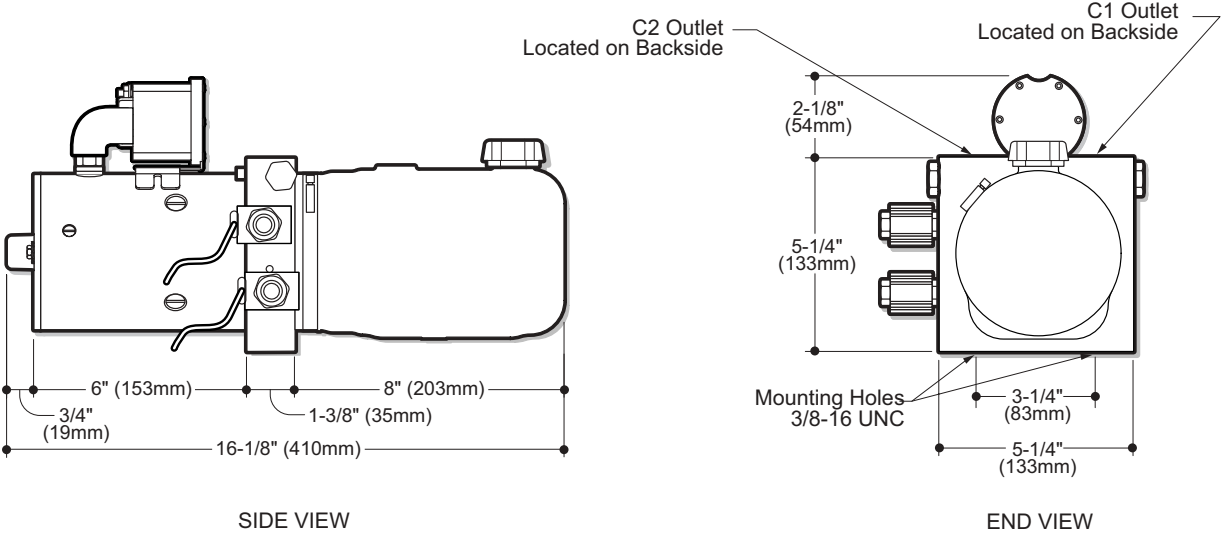
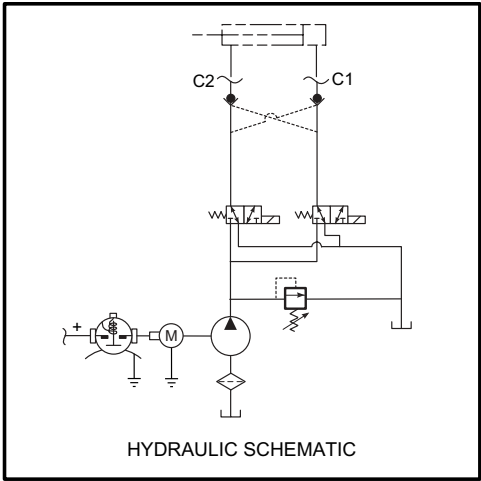

How to Order Your M-3534 Dyna-Jack®

Comprehensive information may be found on the page referenced below each selection category.

Shown as Standard with:							
	08111	12	06102	17757	Horiz.		
PUMP	MOTOR	VOLTAGE	RESERVOIR (LENGTH)	MOTOR START SWITCH	MOUNTING POSITION	OPTIONAL ACCESSORIES	CONTROL STATION
Ref. Page 54.0	Ref. Page 61.0		Ref. Page 87.0-93.0	Ref. Page 96.0		Ref. Page 99.0	Ref. Page 97.0



MODEL M-3547

Description:

- Pump/Motor/Reservoir/Valve
- Check Valve
- 2 x 2-Way /2-Position and 2 x 3-Way/2-Position Solenoid Operated Cartridge Valves Located Externally and Manifoldd Directly to Power Unit. Circuit Operates One Double Acting Cylinder With Both Ports Positively Checked
- Externally Adjustable Relief Valve
- #6 SAE Outlets
- Horizontal Mounting Standard

Popular Option:

- Unit May be Wired to Independently Operate 2 x Single Acting Cylinders. Consult Factory For Proper Control Station
- Externally Adjustable Relief Valve May Be Installed In C1 or C2 Port
- 04286 Valve Spacer is Available to Provide Additional Clearance for Large Reservoirs when Required.
- Vertical Mounting. Motor Up

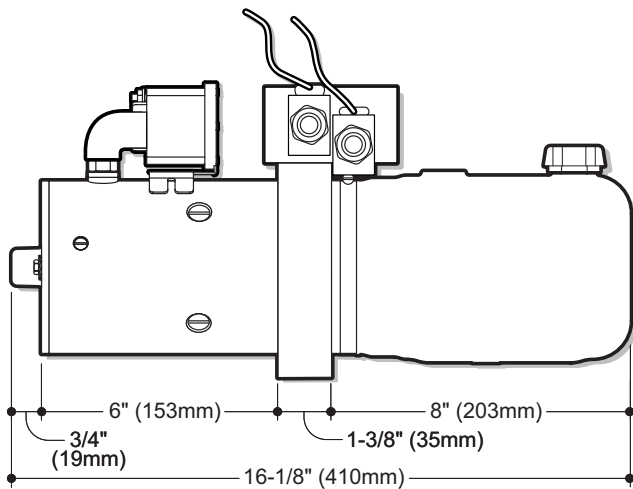
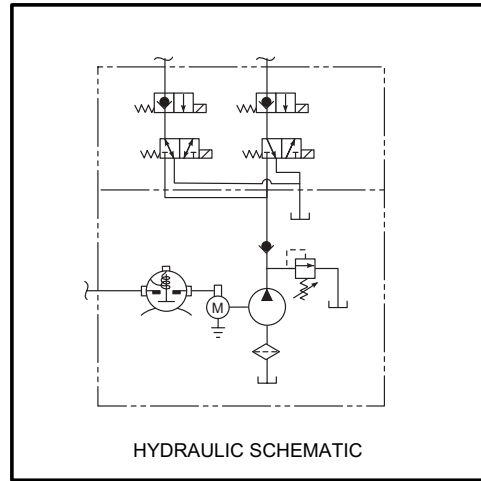

SIDE VIEW

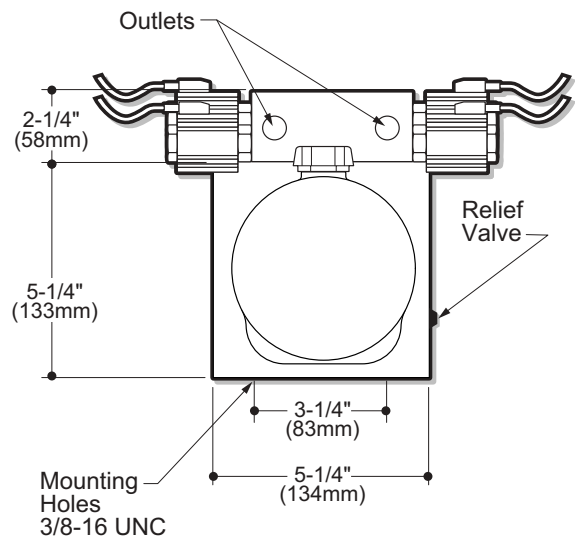

END VIEW

How to Order Your M-3547 Dyna-Jack®

Comprehensive information may be found on the page referenced below each selection category.

Shown as Standard with:							
	08111	12	06102	17757	Horiz.		
PUMP	MOTOR	VOLTAGE	RESERVOIR (LENGTH)	MOTOR START SWITCH	MOUNTING POSITION	OPTIONAL ACCESSORIES	CONTROL STATION
Ref. Page 54.0	Ref. Page 61.0		Ref. Page 87.0-93.0	Ref. Page 96.0		Ref. Page 99.0	Ref. Page 97.0

MODEL M-3551

Description:

- Pump/Motor/Reservoir/Valve
- Check Valve
- Externally Adjustable Relief Valve
- 1 x 4-Way/2-Position and 1 x 2-Way/2-Position Normally Closed Solenoid Cartridge Valve Located in the Base
- C1 Port Positively Checked
- Externally Adjustable Relief Valve in C2 Port
- #6 SAE Outlets
- Horizontal Mounting Standard

Popular Options:

- Pressure Compensated (Cartridge Style) Flow Control Orifice In C1 Port
- Control Box and Cord
- Vertical Mounting. Motor Up

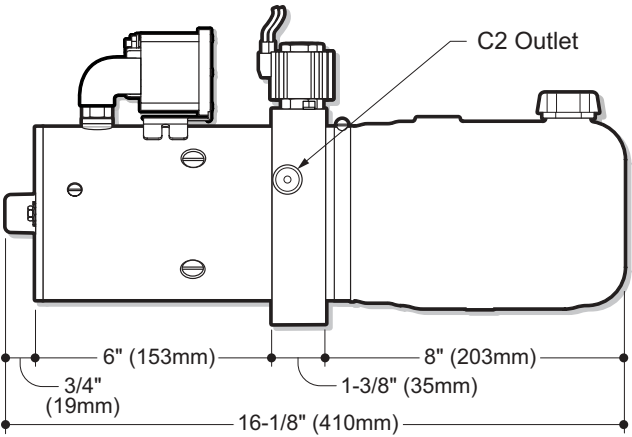
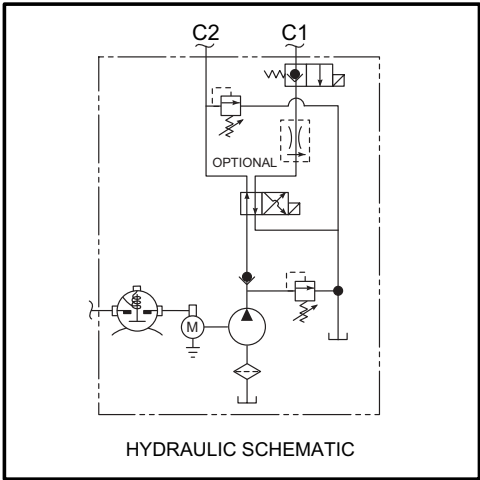

SIDE VIEW

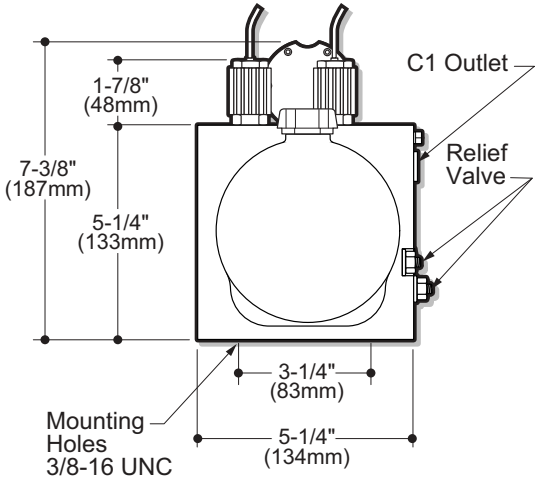

END VIEW

How to Order Your M-3551 Dyna-Jack®

Comprehensive information may be found on the page referenced below each selection category.

Shown as Standard with:							
	08111	12	06102	17757	07995	HORIZ	
PUMP	MOTOR	VOLTAGE	RESERVOIR (LENGTH)	MOTOR START SWITCH	CONTROL STATION	MOUNTING POSITION	OPTIONAL ACCESSORIES
Ref. Page 54.0	Ref. Page 61.0		Ref. Page 87.0-93.0	Ref. Page 96.0	Ref. Page 97.0		Ref. Page 99.0



MODEL M-3551-HF

(High Flow)

Description:

- Pump/Motor/Reservoir/High Flow Valves
- Externally Adjustable Relief Valve
- Main Check Valve
- Total Pressure Drop Thru Base Without Press Comp. Flow Control Installed <150 PSI. (6.9 Bar) at 8 GPM (30 LPM) for Fast and Controlled Lowering Speed
- 1 x 4-Way/2 Position and 1 x 2-Way/2 Position Normally Closed High Flow Solenoid Cartridge Valves Located in the Base (Maximum Lowering Speed Set by Pressure Compensated Orifice
- C1 Port Positively Checked
- Pressure Compensated (Cartridge Style) Orifice in C1 Port For Control of Maximum Lowering Speed
- Externally Adjustable Low Pressure Relief Valve in C2 Port For System Efficiency and Safety
- Horizontal Mounting Standard
- #8 (3/4-16) SAE Outlet

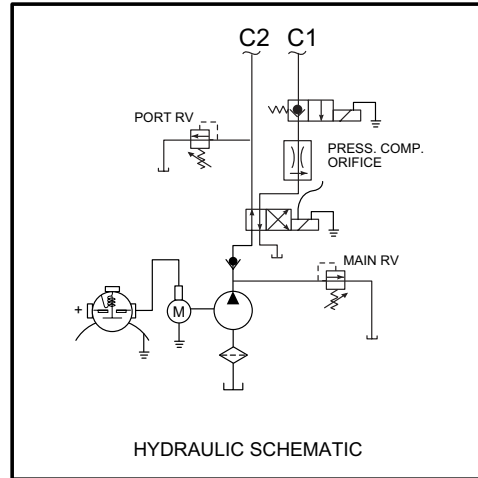

Popular Options

- Control Box and Cord
- Vertical Mounting. Motor Up

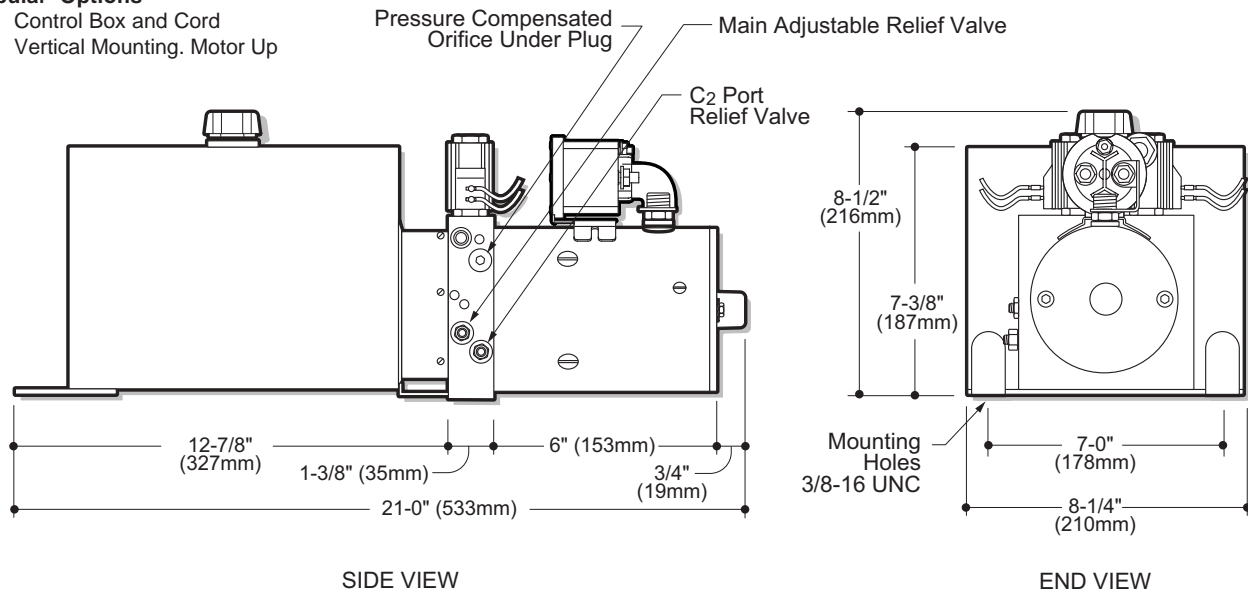

How to Order Your M-3551-HF Dyna-Jack®

Comprehensive information may be found on the page referenced below each selection category.

Shown as Standard with:								
	08111	12	06328	17757	07995		HORIZ	
PUMP	MOTOR	VOLTAGE	RESERVOIR (LENGTH)	MOTOR START SWITCH	CONTROL STATION	MOUNTING BRACKET	MOUNTING POSITION	OPTIONAL ACCESSORIES
Ref. Page 54.0	Ref. Page 61.0		Ref. Page 87.0-93.0	Ref. Page 96.0	Ref. Page 97.0	Ref. Page 98.0		Ref. Page 99.0

MODEL M-3554

Description:

- Pump/Motor/Reservoir/Valve
- Check Valve
- Externally Adjustable Relief Valve
- 1, 4-Way/2-Position for Double-Acting Solenoid Cartridge Valve Located in the Base
- C1 Port Positively Checked
- Externally Adjustable Relief Valve in C2 Port
- Horizontal Mounting Standard
- #6 SAE Outlets

Popular Options:

- Pressure Compensated (Cartridge Style) Flow Control Orifice In C1 Port
- Control Box and Cord
- Vertical Mounting. Motor Up

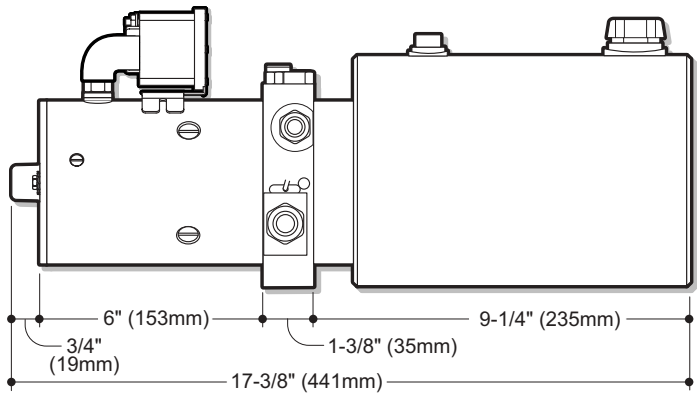
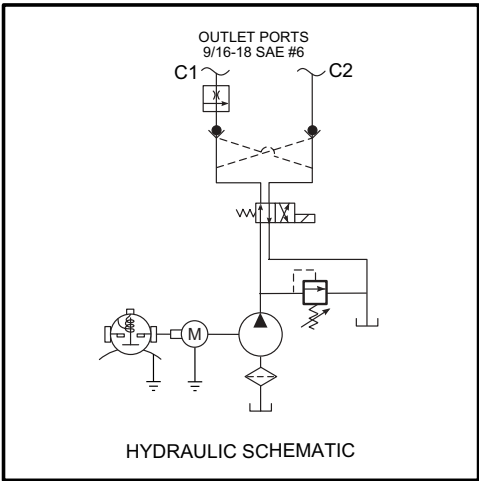

SIDE VIEW

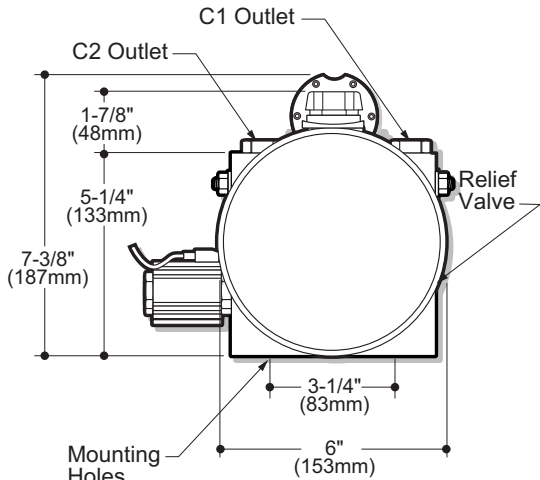

END VIEW

How to Order Your M-3554 Dyna-Jack®

Comprehensive information may be found on the page referenced below each selection category.

Shown as Standard with:							
	08111	12	06042	17757	Horiz.		
PUMP	MOTOR	VOLTAGE	RESERVOIR (LENGTH)	MOTOR START SWITCH	MOUNTING POSITION	OPTIONAL ACCESSORIES	CONTROL STATION
Ref. Page 54.0	Ref. Page 61.0		Ref. Page 87.0-93.0	Ref. Page 96.0		Ref. Page 99.0	Ref. Page 97.0

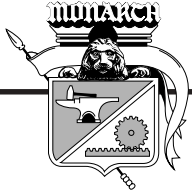

MODEL M-3552

Description:

- Pump/Motor/Reservoir/Valve
- Check Valve
- Externally Adjustable Relief Valve
- 1 x 4-Way/2-Position Solenoid Cartridge Valve and 1 x 2-Way/2-Position Solenoid Cartridge Valve Located Externally. Manifoldded Directly To Unit
- C1 Port Positively Checked
- Externally Adjustable Relief Valve in C2 Port
- #6 SAE Outlets
- Horizontal Mounting Standard

Popular Options:

- Pressure Compensated (Cartridge Style) Flow Control In C1 Port
- Control Box and Cord
- Vertical Mounting. Motor Up

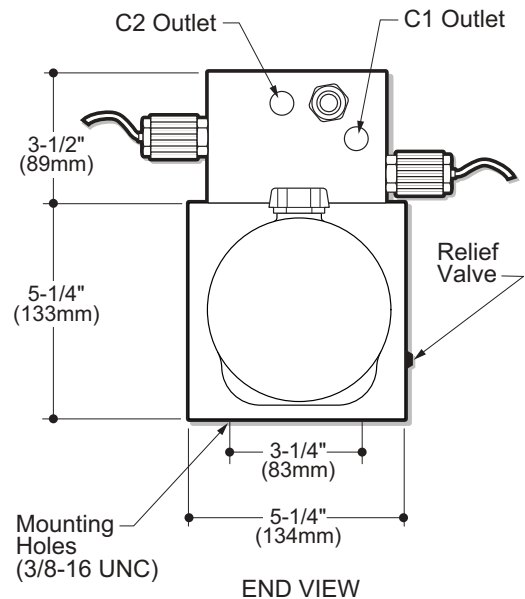
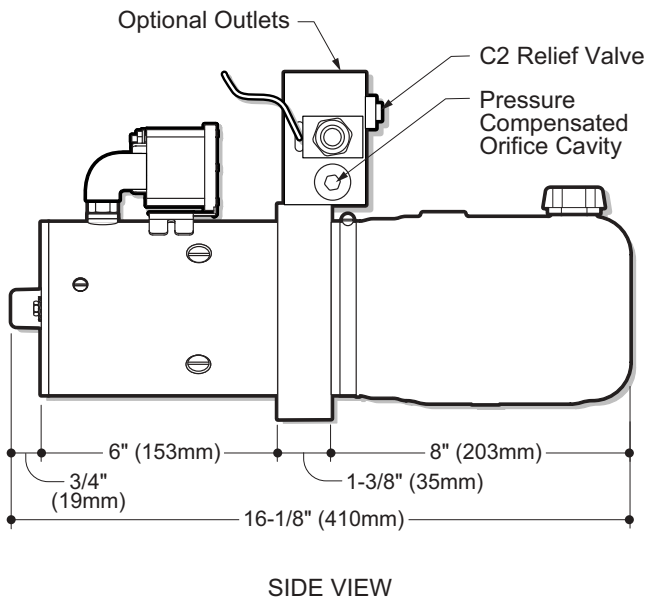
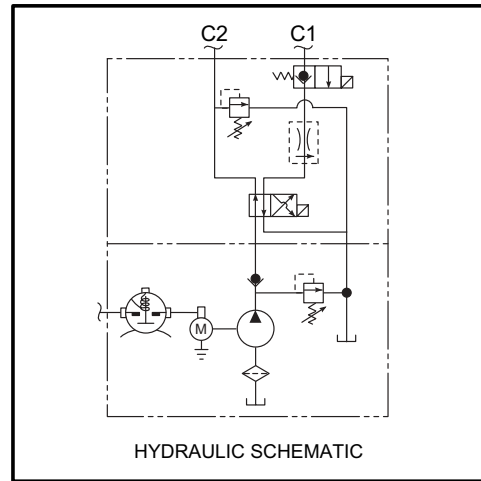

How to Order Your M-3552 Dyna-Jack®

Comprehensive information may be found on the page referenced below each selection category.

Shown as Standard with:							
	08111	12	06102	17757	Horiz.		
PUMP	MOTOR	VOLTAGE	RESERVOIR (LENGTH)	MOTOR START SWITCH	MOUNTING POSITION	OPTIONAL ACCESSORIES	CONTROL STATION
Ref. Page 54.0	Ref. Page 61.0		Ref. Page 87.0-93.0	Ref. Page 96.0		Ref. Page 99.0	Ref. Page 97.0

MODEL M-642

Description:

- Pump/Motor/Reservoir/Valve
- Check Valve
- 4-Way/2-Position and 2-Way/2-Position N.C. Solenoid Cartridge Valves Located Inside Reservoir
- C1 Port Positively Checked
- C1 and C2 Ports are Filtered
- Externally Adjustable Relief Valve
- .250 Inch NPT Outlets
- Horizontal Mounting Standard

Popular Option:

- Low Pressure Relief Valve In "R" Port
- Vertical Mounting. Motor Up
- Control Box and Cable

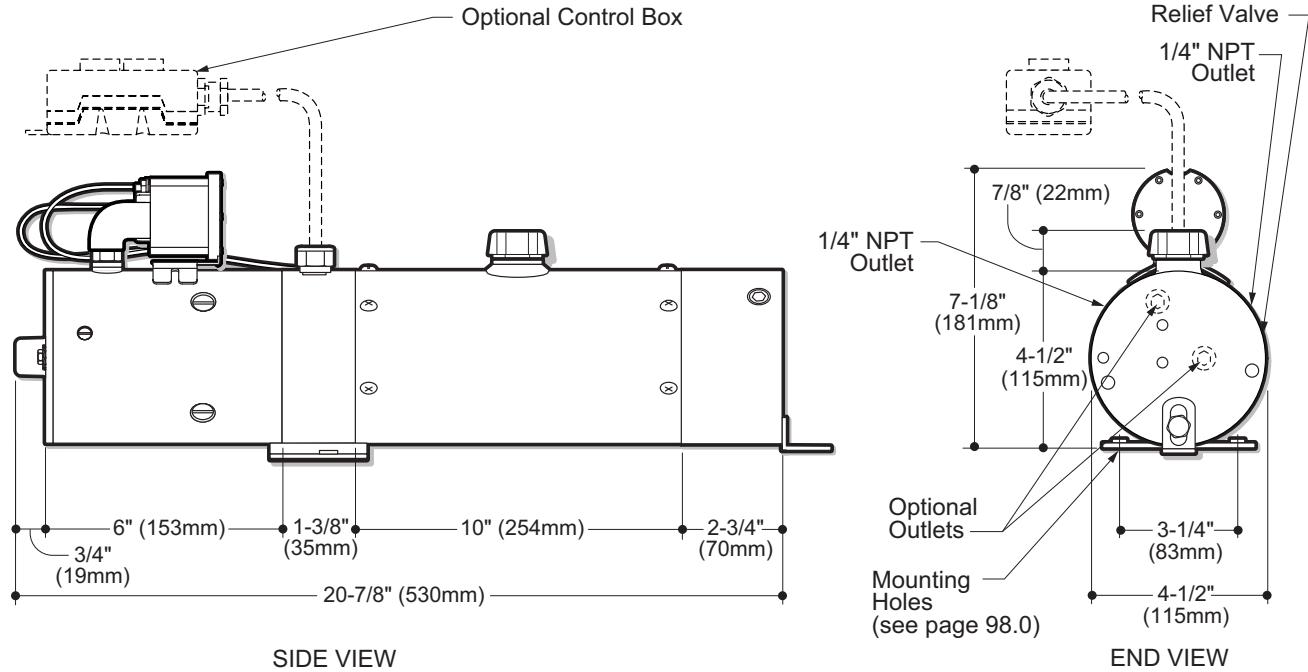
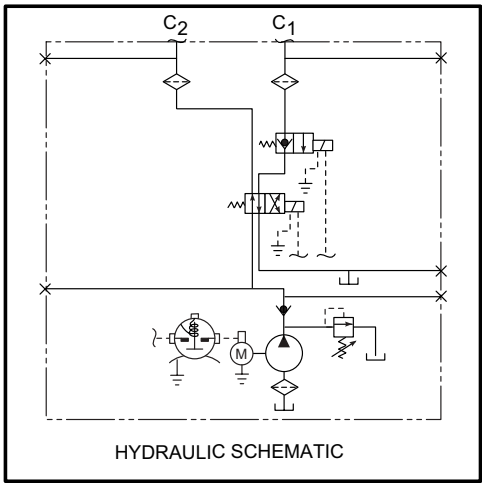

How to Order Your M-642 Dyna-Ramic®

Comprehensive information may be found on the page referenced below each selection category.

Shown as Standard with:								
	08111	12	06657	17757	07995		HORIZ	
PUMP	MOTOR	VOLTAGE	RESERVOIR (LENGTH)	MOTOR START SWITCH	CONTROL STATION	MOUNTING BRACKET	MOUNTING POSITION	OPTIONAL ACCESSORIES
Ref. Page 54.0	Ref. Page 61.0		Ref. Page 87.0-93.0	Ref. Page 96.0	Ref. Page 97.0	Ref. Page 98.0		Ref. Page 99.0



MODEL M-500-4W/3W

Description:

- Pump/Motor/Reservoir/Valve
- Check Valve
- Manually Operated 3-Way Valve (Outlet Port Checked) and 4-Way Valve. Electrical Contacts for Starting Motor When Valve Is Actuated
- Externally Adjustable Relief Valve
- .250 Inch NPT Outlets
- Horizontal Mounting Standard

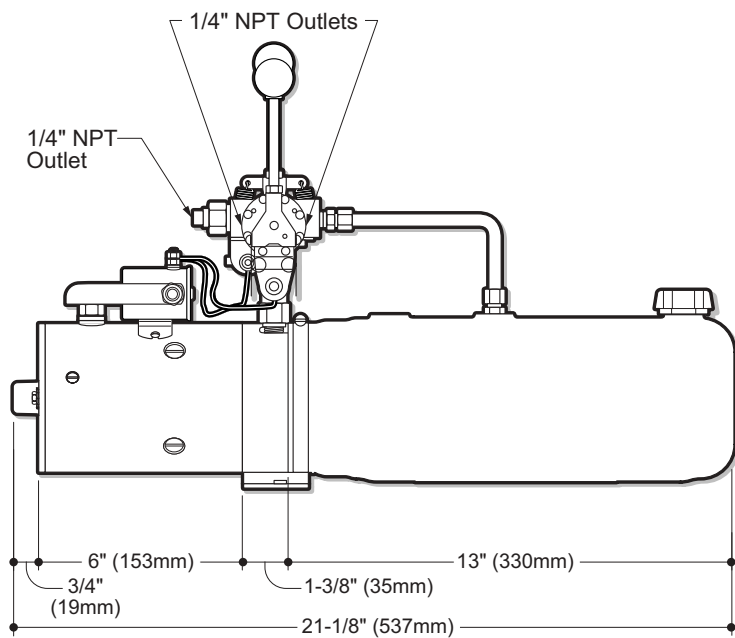
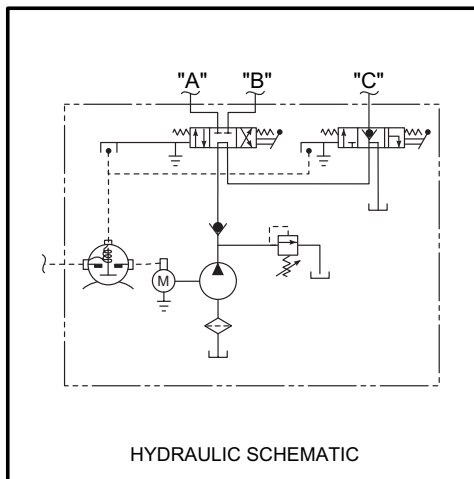

SIDE VIEW

Optional Eye-Bolt

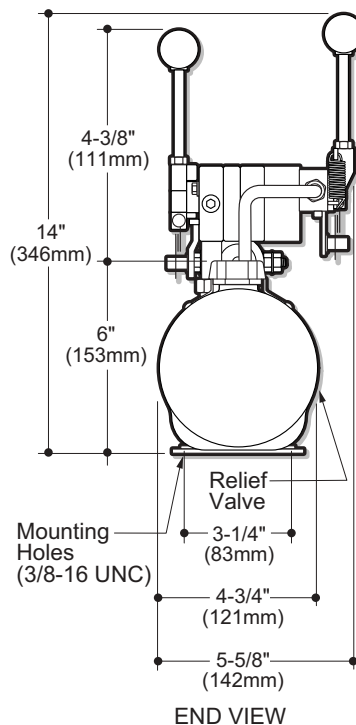

END VIEW

How to Order Your M-500-4W/3W

Comprehensive information may be found on the page referenced below each selection category.

Shown as Standard with:							
	08111	12	06105	03336	04560	HORIZ	
PUMP	MOTOR	VOLTAGE	RESERVOIR (LENGTH)	MOTOR START SWITCH	MOUNTING BRACKET	MOUNTING POSITION	OPTIONAL ACCESSORIES
Ref. Page 54.0	Ref. Page 61.0		Ref. Page 87.0-93.0	Ref. Page 96.0	Ref. Page 98.0		Ref. Page 99.0

MODEL M-683

Description:

- Pump/Motor/Reservoir/Valve
- Check Valve
- 1 4-Way/2-Position and 3 x 2-Way/2-Position N.C. Solenoid Cartridge Valves Located Inside Reservoir provide 4W/3W Function
- All Ports Filtered
- By-Pass (Also Referred to as Cross-Over) Relief Valves Are Located Between C1 and C2 Ports
- Cord with Connector Plug
- Externally Adjustable Relief Valve
- .250 Inch NPT Outlets
- Horizontal Mounting Standard

Popular Option:

- Vertical Mounting. Motor Up
- Control Box

Typical Application:

- Snow Plow. Up. Down. Float; Left. Right

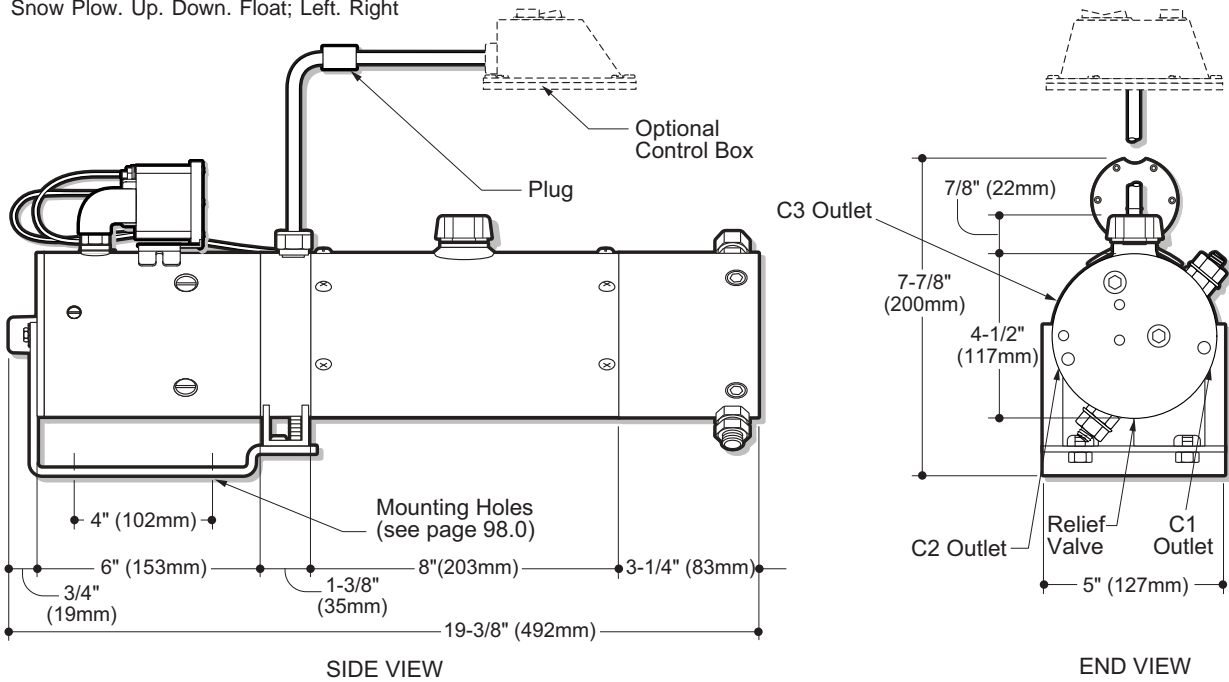
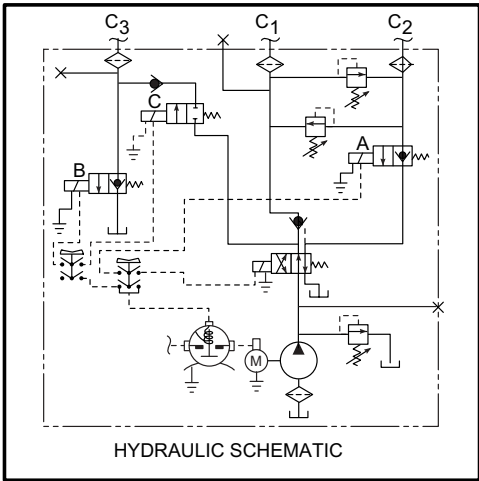

How to Order Your M-683 Dyna-Ramic®

Comprehensive information may be found on the page referenced below each selection category.

Shown as Standard with:								
	08111	12	06703	17757	03197	02238	HORIZ	
PUMP	MOTOR	VOLTAGE	RESERVOIR (LENGTH)	MOTOR START SWITCH	CONTROL STATION	MOUNTING BRACKET	MOUNTING POSITION	OPTIONAL ACCESSORIES
Ref. Page 54.0	Ref. Page 61.0		Ref. Page 87.0-93.0	Ref. Page 96.0	Ref. Page 97.0	Ref. Page 98.0		Ref. Page 99.0

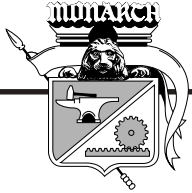

MODEL M-3528

Description:

- Pump/Motor/Reservoir/Valve
- Check Valve in "P" Port
- Externally Adjustable Relief Valve
- 2 x D03 Solenoid Valve
- #6 SAE Outlets
- Horizontal Mounting Standard

Popular Options:

- Control Box and Cord
- Vertical Mounting. Motor Up
- Large Selection of D03/CETOP Valves and Accessories

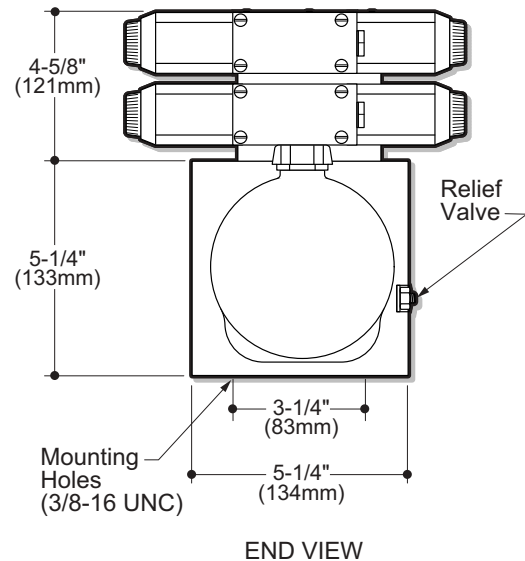
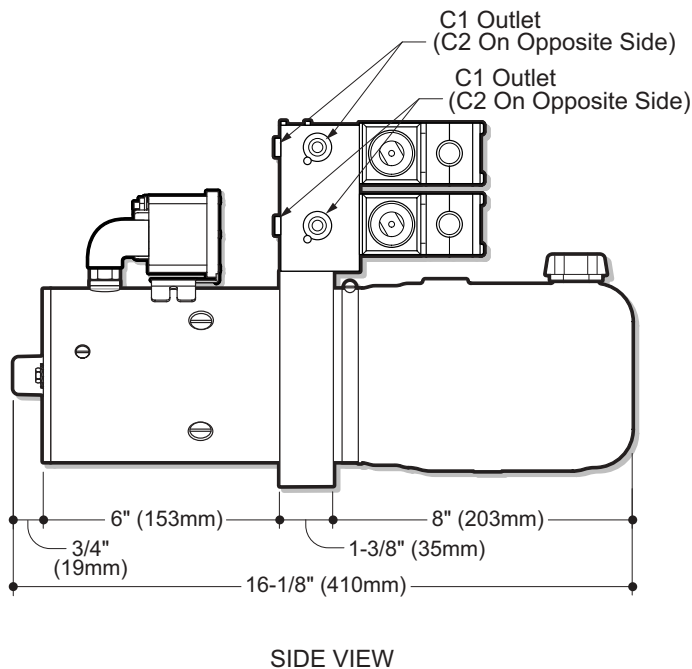
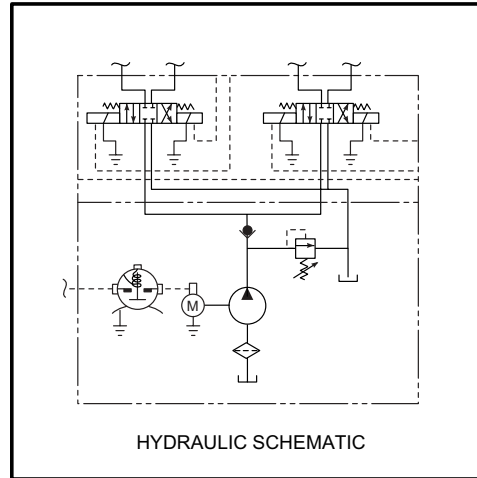

NOTE:
An Adapter May Be Required With Certain Reservoirs - Consult Factory.

How to Order Your M-3528 Dyna-Jack®

Comprehensive information may be found on the page referenced below each selection category.

Shown as Standard with:							
	08111	12	06102	17757	Horiz.		
PUMP	MOTOR	VOLTAGE	RESERVOIR (LENGTH)	MOTOR START SWITCH	MOUNTING POSITION	OPTIONAL ACCESSORIES	CONTROL STATION
Ref. Page 54.0	Ref. Page 61.0		Ref. Page 87.0-93.0	Ref. Page 96.0		Ref. Page 99.0	Ref. Page 97.0

MODEL M-3529

Description:

- Pump/Motor/Reservoir/Valve
- Check Valve in "P" Port
- Externally Adjustable Relief Valve
- #6 SAE Outlets
- Horizontal Mounting Standard

Popular Options:

- Control Box and Cord
- Vertical Mounting. Motor Up
- Large Selection of D03/CETOP Valves and Accessories

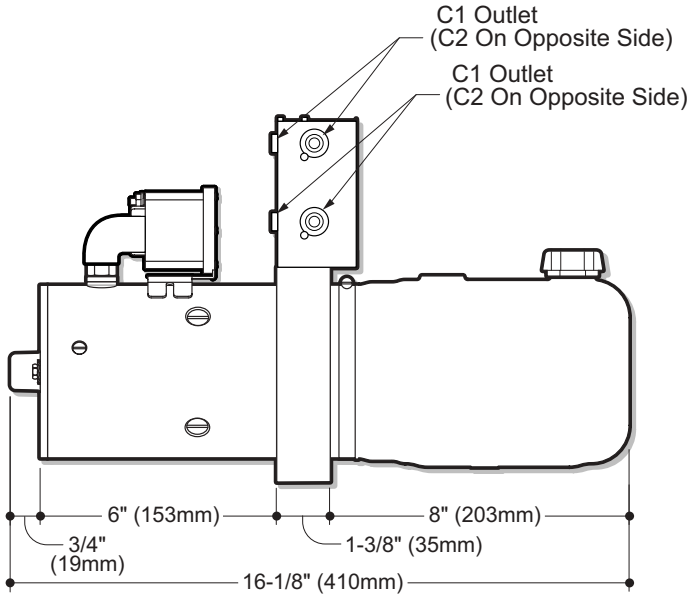
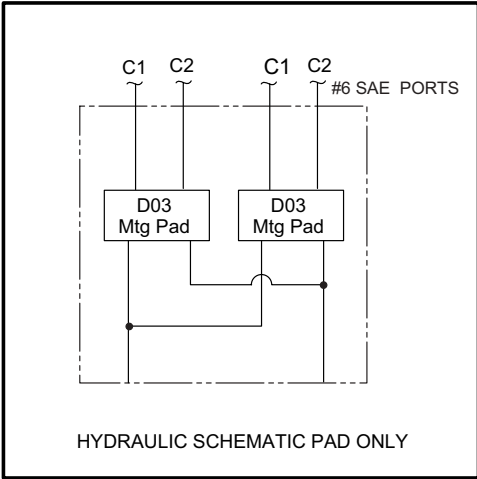

SIDE VIEW

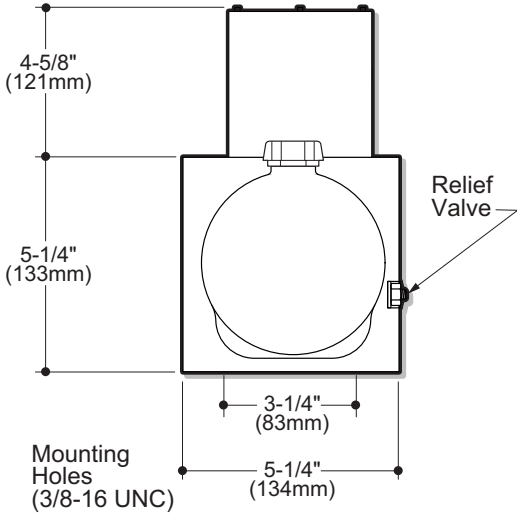

END VIEW

NOTE:
An Adapter May Be Required With Certain Reservoirs - Consult Factory.

How to Order Your M-3529 Dyna-Jack®

Comprehensive information may be found on the page referenced below each selection category.

Shown as Standard with:							
	08111	12	06102	17757	Horiz.		
PUMP	MOTOR	VOLTAGE	RESERVOIR (LENGTH)	MOTOR START SWITCH	MOUNTING POSITION	OPTIONAL ACCESSORIES	CONTROL STATION
Ref. Page 54.0	Ref. Page 61.0		Ref. Page 87.0-93.0	Ref. Page 96.0		Ref. Page 99.0	Ref. Page 97.0

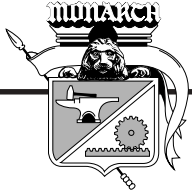

MODEL M-3593

Description:

- Pump/Motor/Reservoir/Valve
- Externally Adjustable Relief Valve
- Solenoid Cartridge Valves, Pilot Operated Check Valves and Adjustable Cross-Over Relief System Mounted In a Compact Manifold
- Ideal System For Operating a Snow Plow. Power Up, Hold, Gravity Down, Left, Right
- Horizontal Mounting Standard

Popular Option:

- Control Box and Cord
- Vertical Mounting. Motor Up

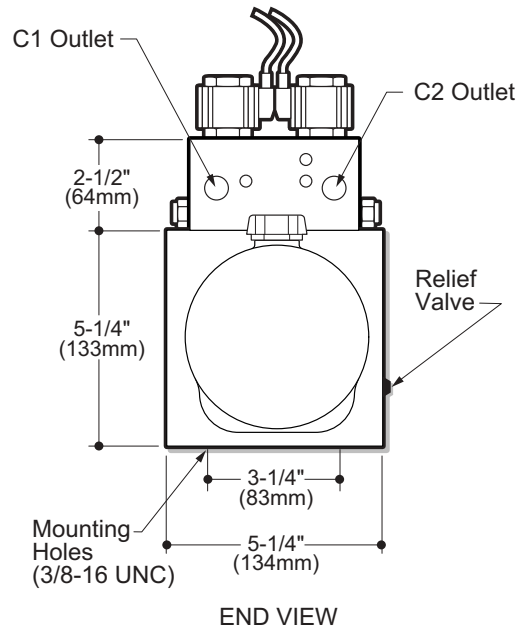
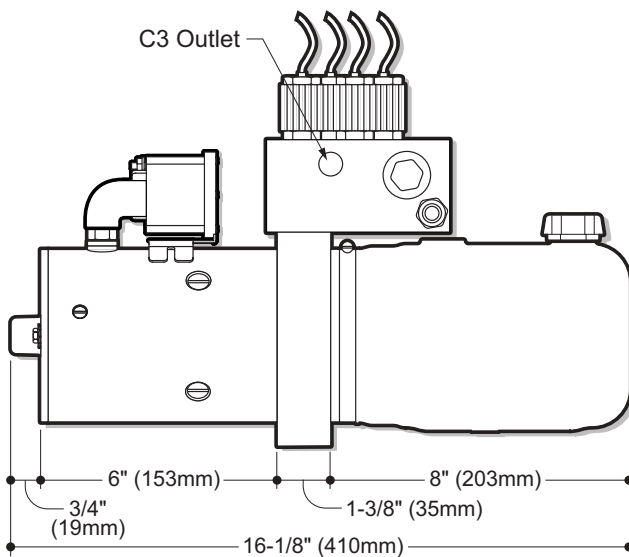
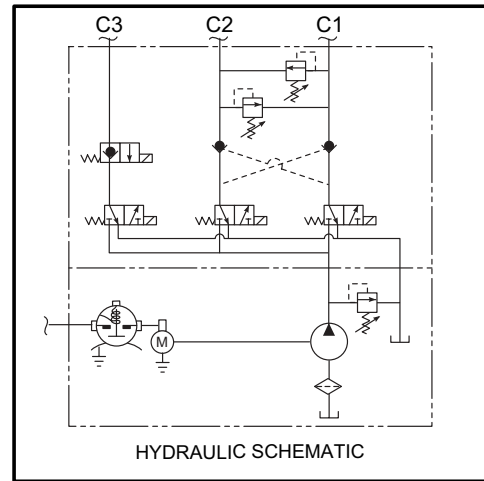

How to Order Your M-3593 Dyna-Jack®

Comprehensive information may be found on the page referenced below each selection category.

Shown as Standard with:							
	08111	12	06102	17757	Horiz.		
PUMP	MOTOR	VOLTAGE	RESERVOIR (LENGTH)	MOTOR START SWITCH	MOUNTING POSITION	OPTIONAL ACCESSORIES	CONTROL STATION
Ref. Page 54.0	Ref. Page 61.0		Ref. Page 87.0-93.0	Ref. Page 96.0		Ref. Page 99.0	Ref. Page 97.0

NOTES :

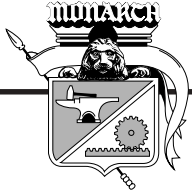

Monarch Modular Power Units

Description:

- Add Standard or Custom Manifolds to a Basic M-3598 Power Unit with "P" and "T" Ports.
- Modular Manifolds Mount to Standard Pad. Allow for a Building Block Approach to Power Unit Flexibility and Circuit Design.
- For Use With All Monarch Pumps, Motors, and Reservoirs. Note - A spacer may be required with certain reservoirs, on others the valve package may cover reservoir fill and return ports - consult factory.

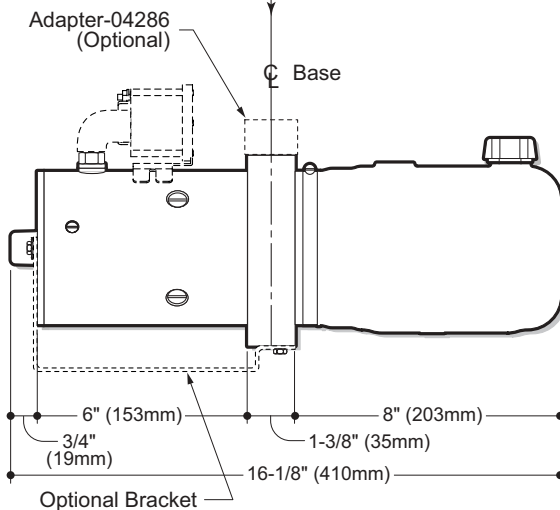
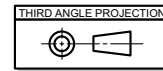
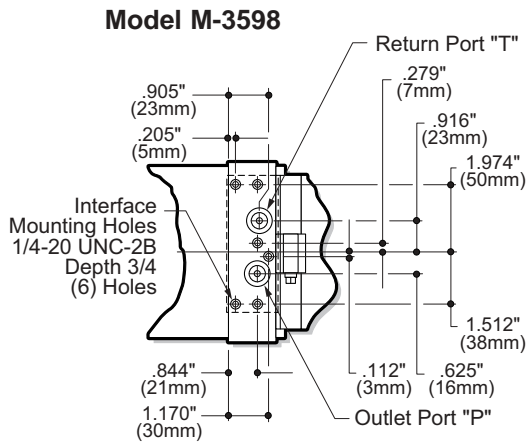
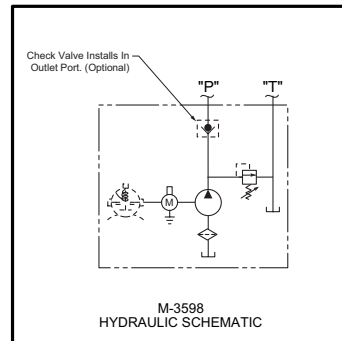

SIDE VIEW

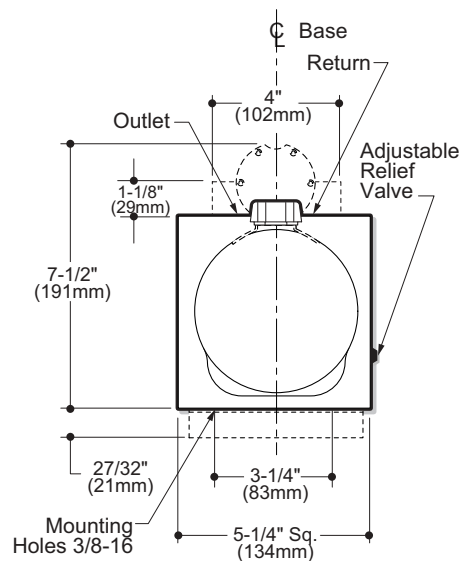

END VIEW

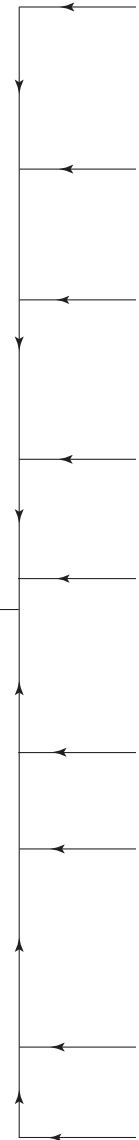

Add Any Of The Following Circuits To The M-3598 Power unit

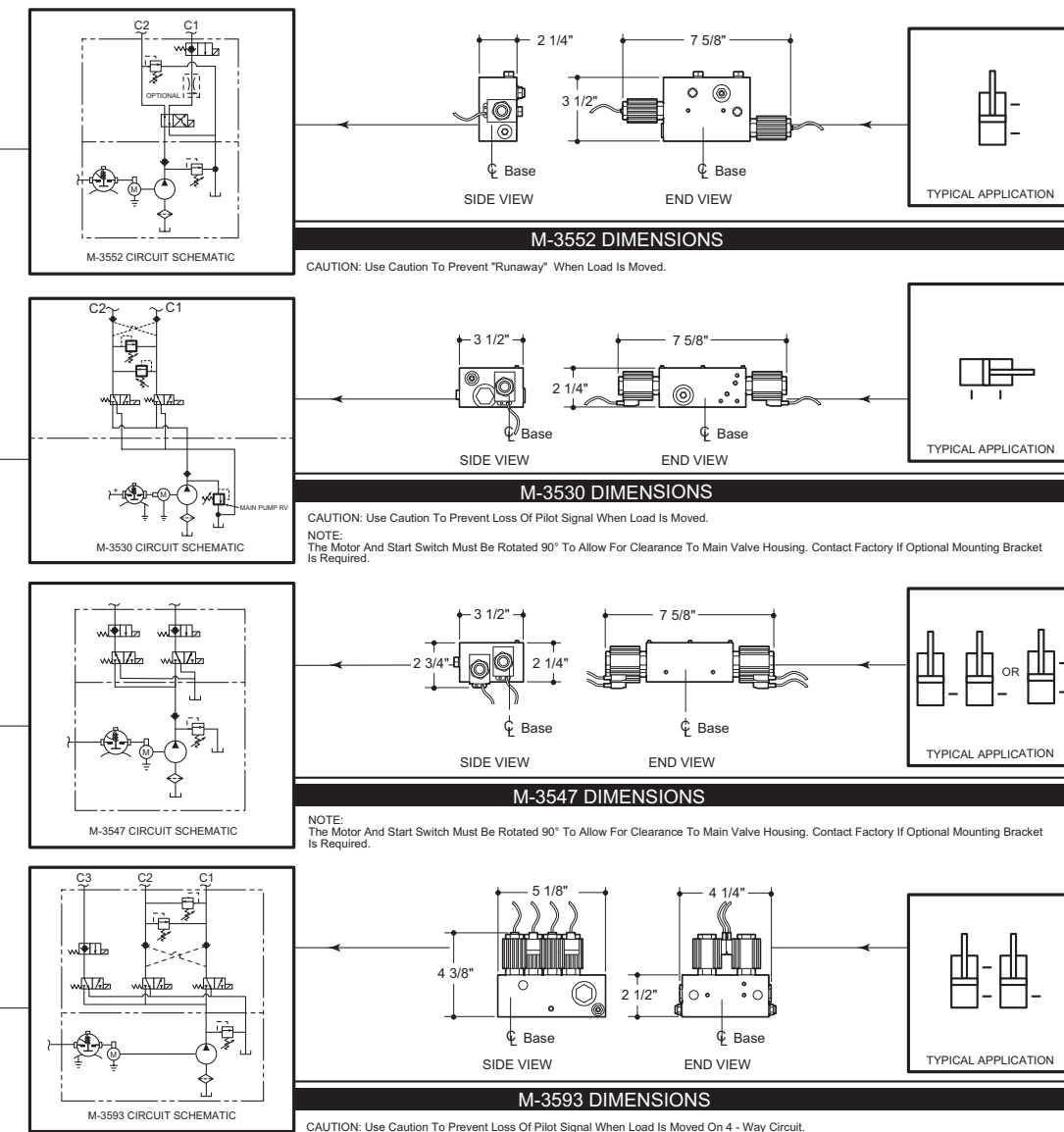
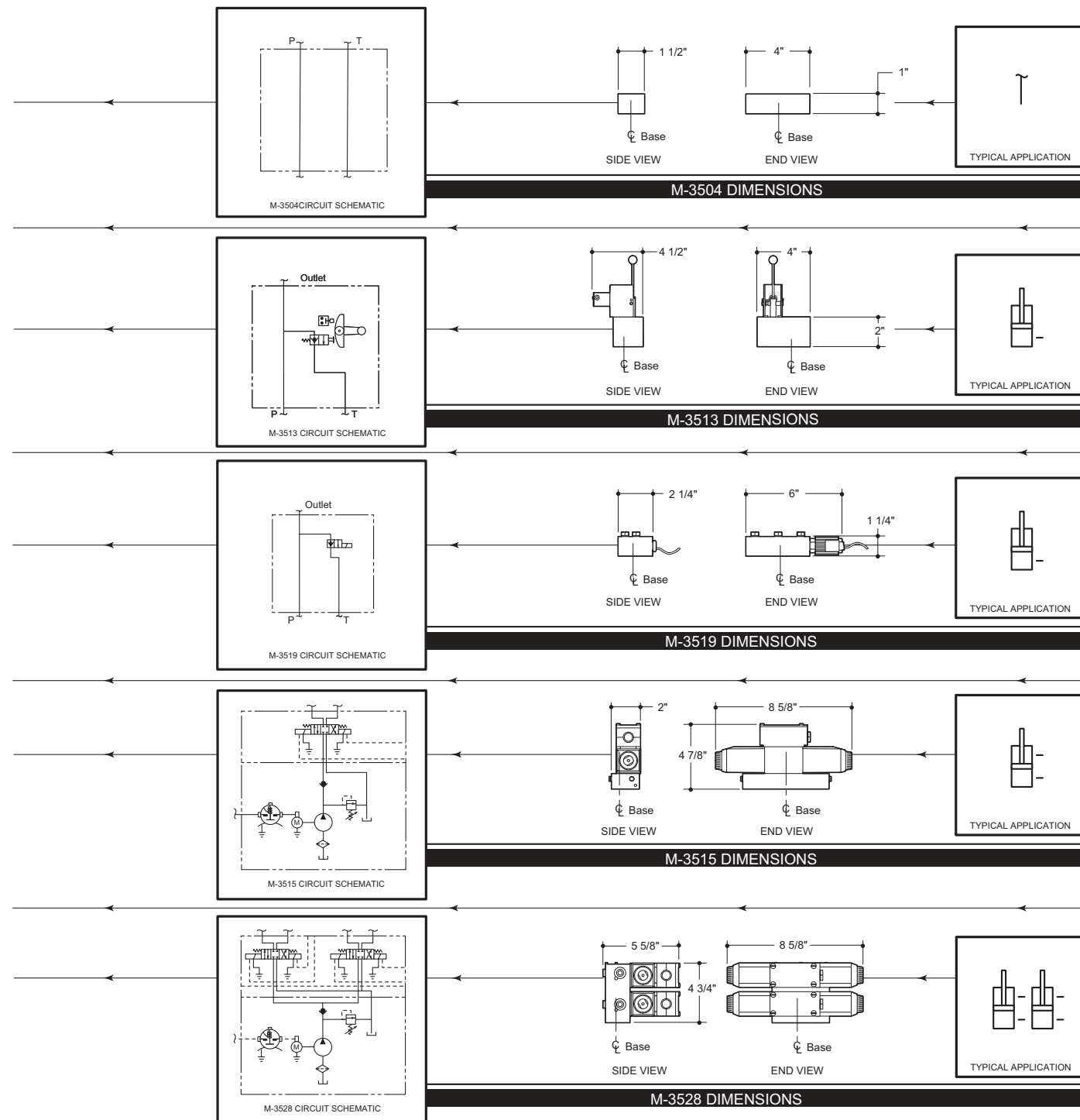



Monarch Modular Systems
Flexible Solutions As You Need Them

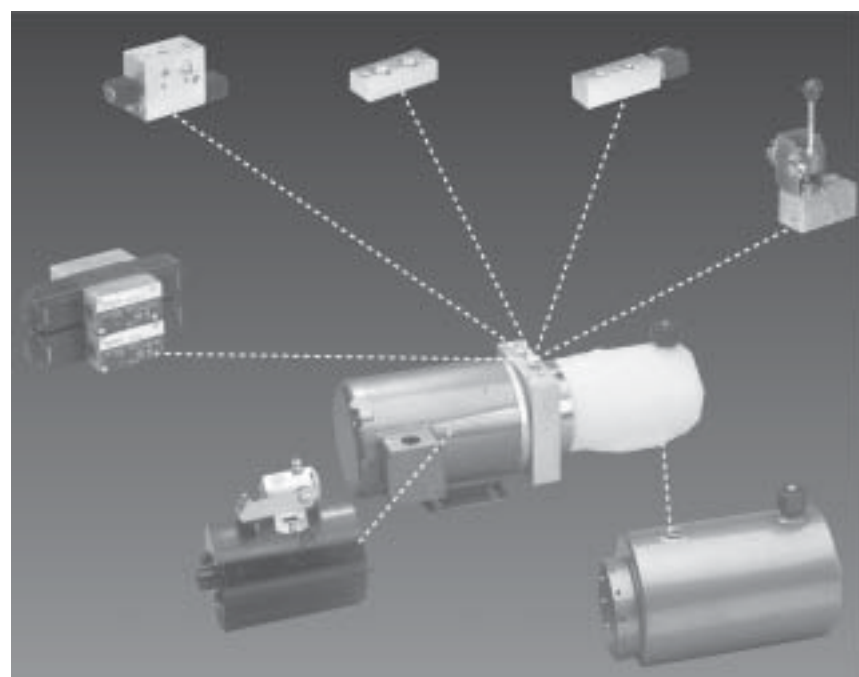

How to Order Your Monarch Modular Power Unit

Select from the following options. Comprehensive information may be found on the page referenced below each selection category.

MODEL M - - M (MODULAR)

SELECT MODEL	PUMP Ref. Page 54.0	MOTOR Ref. Page 85.0	VOLTAGE	RESERVOIR (LENGTH) Ref. Page 87.0-93.0	CONTROL STATION Ref. Page 97.0	MOTOR START SWITCH Ref. Page 96.0	MOUNTING BRACKET Ref. Page 98.0	MOUNTING POSITION
M-3598	-150	08053	12	4.5 x 8	03317	17757	Optional	Horizontal
M-3504-M	-190	08111	12	4.5 x 10	03406	03335	02238	
M-3513-M	-270	08058	12	4.5 x 12	03404	04295	01289	Vertical
M-3519-M	-150	08058	12	4.5 x 13	03453			
M-3515-M	-200	08112	12		03409	17744		
M-3528-M	-250	08092	12	6 x 9	03410			
M-3542-M*	-200	08117	12	6 x 10	03487			
M-3552-M*	-380	08056	12	6 x 13.5	03251			
M-3530-M*		08100	12	6 x 18	03451			
M-3547-M*		08050	12		07993			
M-3593M*		08163	12	5.5 x 6.5 x 10	03197			
		08051	24	5.5 x 6.5 x 13.5	03201	03467		
		08120	24	5.5 x 6.5 x 19	07995	03463		
		08057	24			04296		
		08035	24	6.25 x 7 x 7	Specify Cord Length Inches	07519		
		08055	36	6.25 x 7 x 10		07523		
		08168	36	6.25 x 7 x 12				
		08055	48	6.25 x 7 x 15		Bus Bar		
		08174	72	6.25 x 7 x 15		Start Switch to Motor Cable		
				6.25 x 7 x 21				
		Special		Special				

*Max Flow = 2.75 GPM



S-326 Pump/Motor Units

S-326 Units Feature SAE AA and SAE A Pumps and Permanent Magnet Motors.

Permanent magnet motors are typically used to operate hydraulic equipment for material handling devices, aerial platforms, and emergency back-up systems because they provide extended run times and linear pump outputs at various pressures for smooth operation. Pressure loaded pumps deliver high volumetric efficiency and are fitted with spline shafts for optimum engagement with the motor drive shaft.

Please select a motor and pump combination from the following chart and performance curves. Motor thermal data (run time) may be found on page 86.

PART NUMBER	VOLTAGE	PUMP INTERFACE	INSULATION CLASS	DIMENSIONS PAGE	PERFORMANCE CURVE	NUMBER OF TERMINALS	FRAME	UL LISTED	DESCRIPTION *SEE KEY
08164	12	SAE AA 1/2" Spline	F	45.0	AA	2	48 (5.6" Ø)	No	OFC
08166	24	SAE AA 1/2" Spline	F	45.0	AB	2	48 (5.6" Ø)	No	OFC
08167	24	SAE A 5/8" Spline	F	45.0	AD	2	48 (5.6" Ø)	No	OFC
08169	36	SAE AA 1/2" Spline	F	45.0	AF	2	48 (5.6" Ø)	No	OFC
08170	36	SAE A 5/8" Spline	F	45.0	AG	2	48 (5.6" Ø)	No	OFC
08171	48	SAE AA 1/2" Spline	F	45.0	AH	2	48 (5.6" Ø)	No	OFC
08172	48	SAE A 5/8" Spline	F	45.0	AI	2	48 (5.6" Ø)	No	OFC
08175	72	SAE AA 1/2" Spline	F	45.0	AJ	2	48 (5.6" Ø)	No	OFC
08176	72	SAE A 5/8" Spline	F	45.0	AK	2	48 (5.6" Ø)	No	OFC
08734		BAND KIT							

*Abbreviation Key:
OFC = Open Fan Cooled

A band kit is available that will convert the motor from OFC to EFC (Enclosed Fan Cooled). Use of the band reduces thermal performance. Please contact the factory for more information.

Specifications, descriptions, and illustrative material contained herein were as accurate as known at the time this publication was approved for printing. Monarch Hydraulics, Inc. reserves the right to discontinue models at any time or change specifications without notice or incurring obligation.

Dimensional Information for S-326 Pump/Motor Units

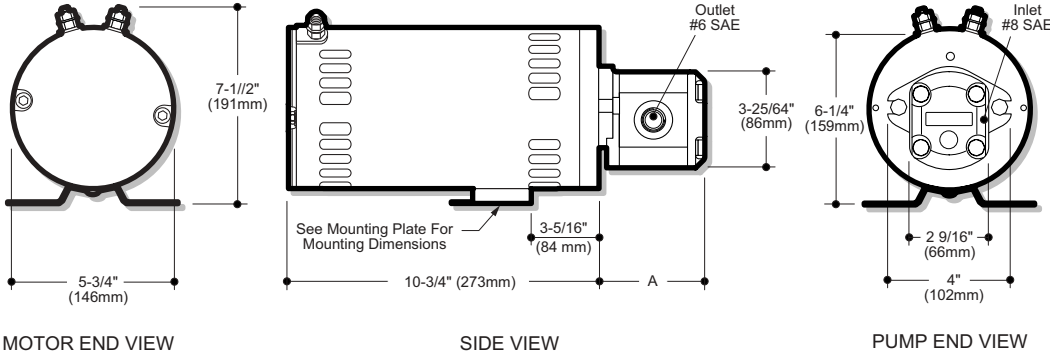

End View and Side View of Motor with SAE AA Pump

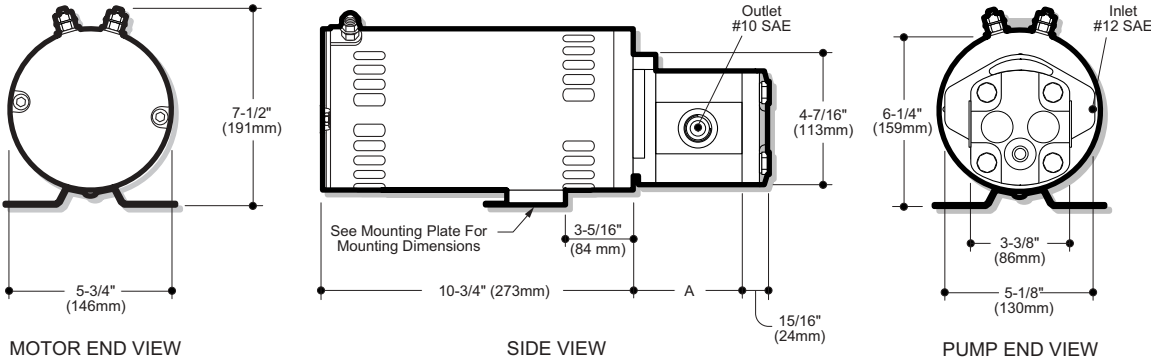

End View and Side View of Motor with SAE A Pump

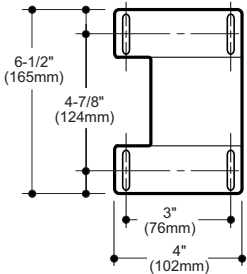

View of Mounting Plate

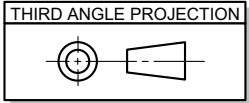



SAE AA Pump Data

PUMP CODE	DISPLACEMENT In ³ /Rev	"A" DIMENSION (Inches)
1.4	0.081	3.23
2.1	0.126	3.23
2.8	0.166	3.23
3.5	0.200	3.46
4.1	0.248	3.46
5.2	0.317	3.70
6.1	0.369	3.70

SAE A Pump Data

PUMP CODE	DISPLACEMENT In ³ /Rev	"A" DIMENSION (Inches)
4.5	0.27	1.83
6.2	0.37	1.83
8.3	0.50	2.05

12 Volt D.C. Performance Curves

$$\text{Voltage} = 12.3 - \sqrt{\frac{\text{AMP} - 70}{43}}$$

Test Fluid = Mobil D.T.E. 24
 @ 100°F (SUS 160)
 34°C (CST 34)

Performance Curve AA

SAE AA Pumps

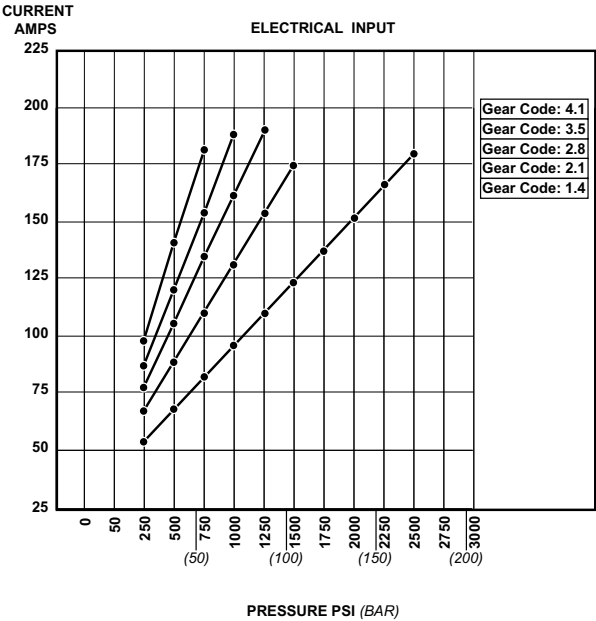
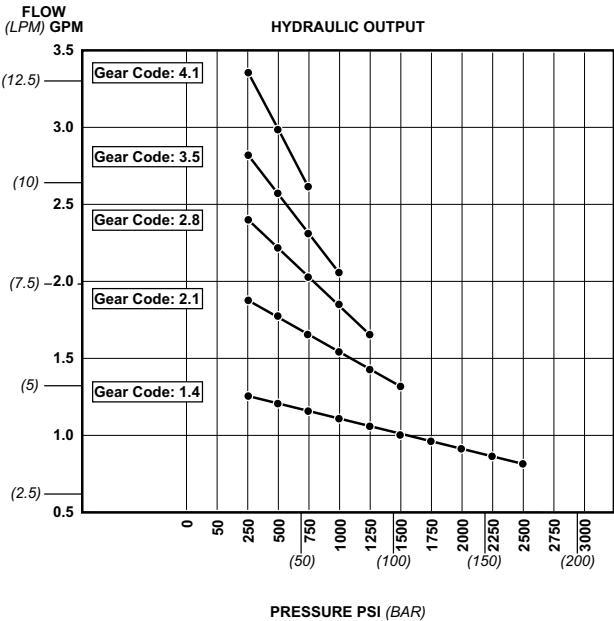

24 Volt D.C. Performance Curves

$$\text{Voltage} = 25.2 - \sqrt{\frac{\text{AMP} - 40}{10}}$$

Test Fluid = Mobil D.T.E. 24
 @ 100°F (SUS 160)
 34°C (CST 34)

Performance Curve AB

SAE AA Pumps

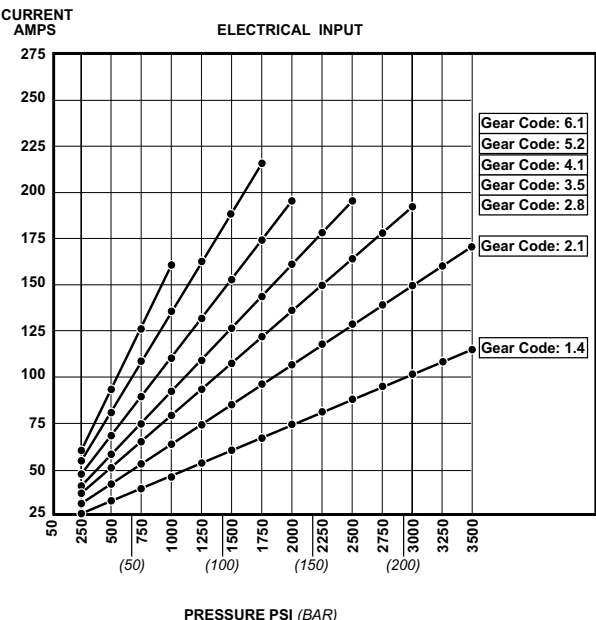
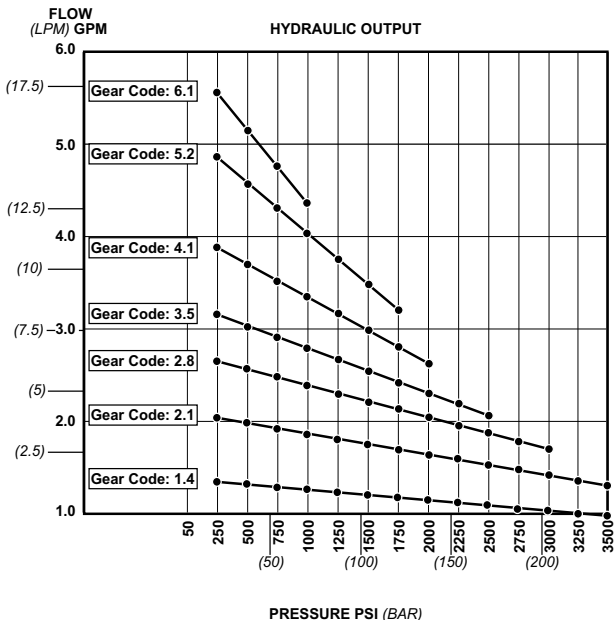



Monarch D.C. Hydraulic Power Systems

24 Volt D.C. Performance Curves

$$\text{Voltage} = 25.2 - \sqrt{\frac{\text{AMP} - 40}{10}}$$

Test Fluid = Mobil D.T.E. 24
 @ 100°F (SUS 160)
 34°C (CST 34)

Performance Curve AC

M Series Pumps

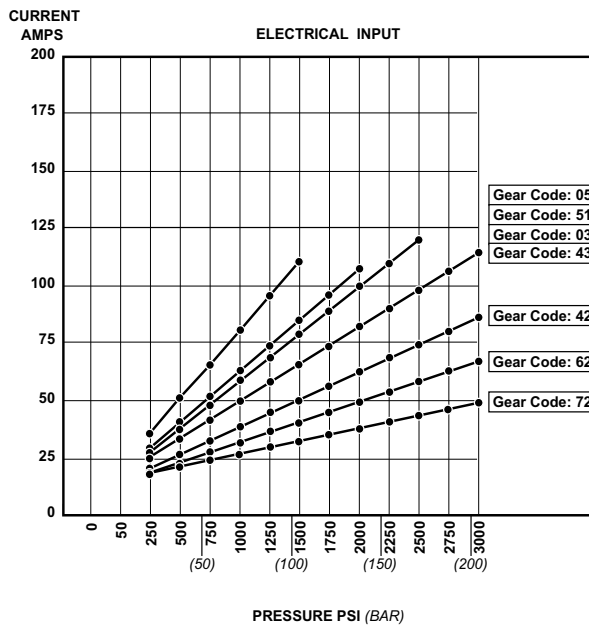
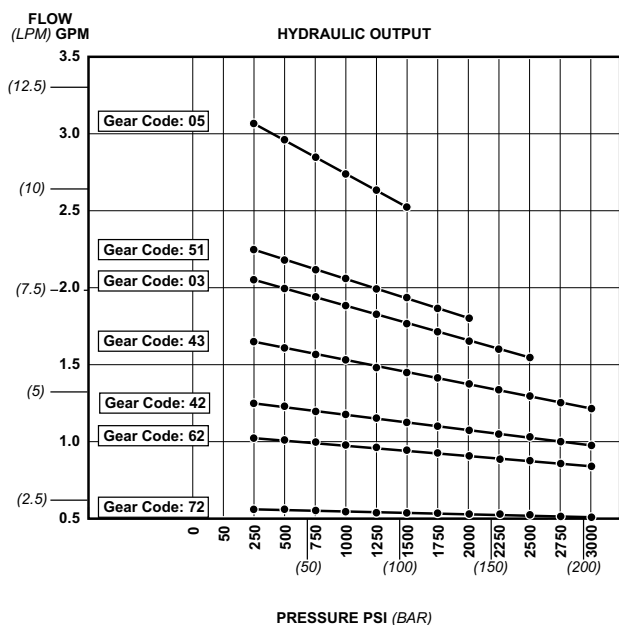

24 Volt D.C. Performance Curves

$$\text{Voltage} = 25.2 - \sqrt{\frac{\text{AMP} - 40}{10}}$$

Test Fluid = Mobil D.T.E. 24
 @ 100°F (SUS 160)
 34°C (CST 34)

Performance Curve AD

SAE A Pumps

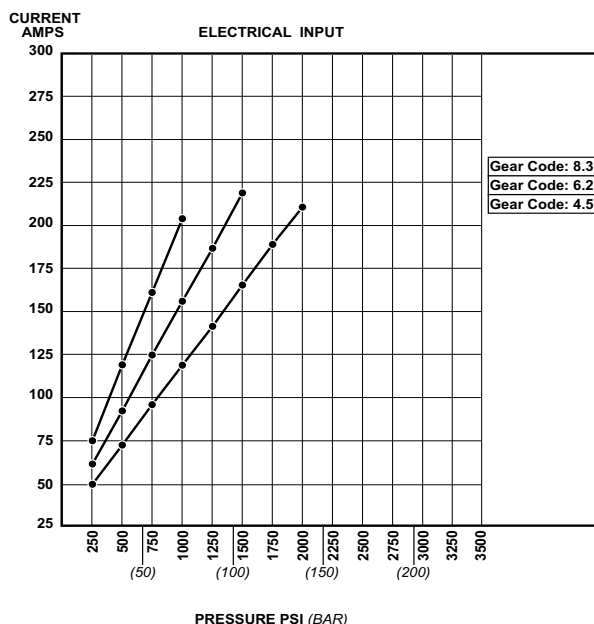
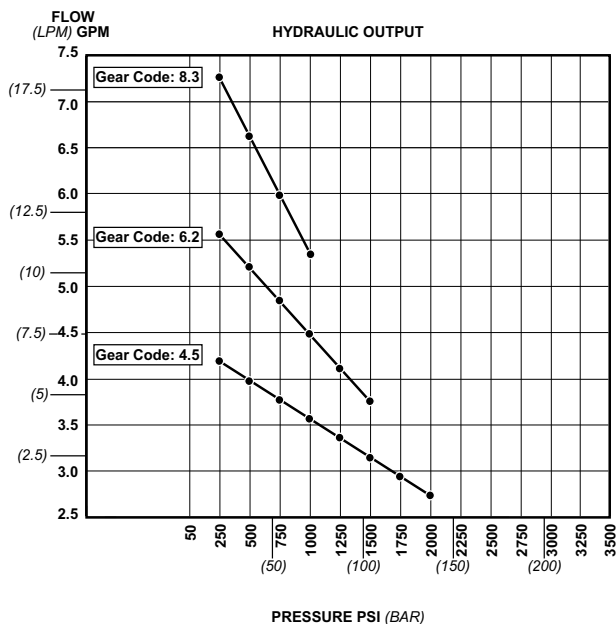

36 Volt D.C. Performance Curves

Voltage = 36.5 - .03 x AMPS

Test Fluid = Mobil D.T.E. 24
 @ 100°F (SUS 160)
 34°C (CST 34)

Performance Curve AE

M Series Pumps

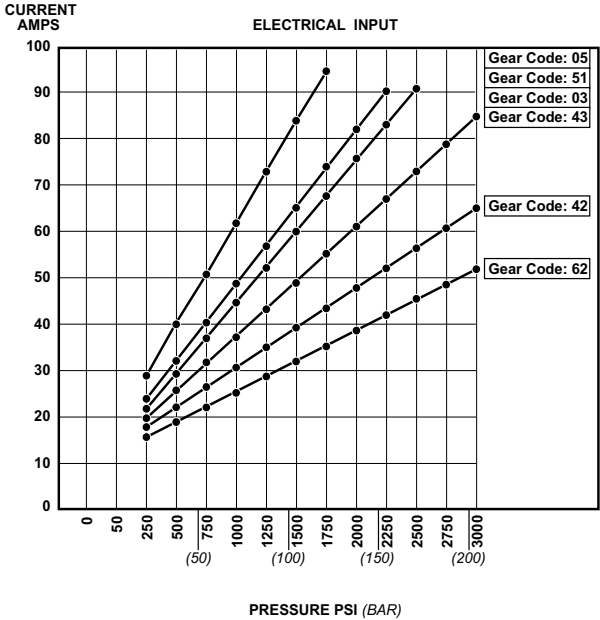
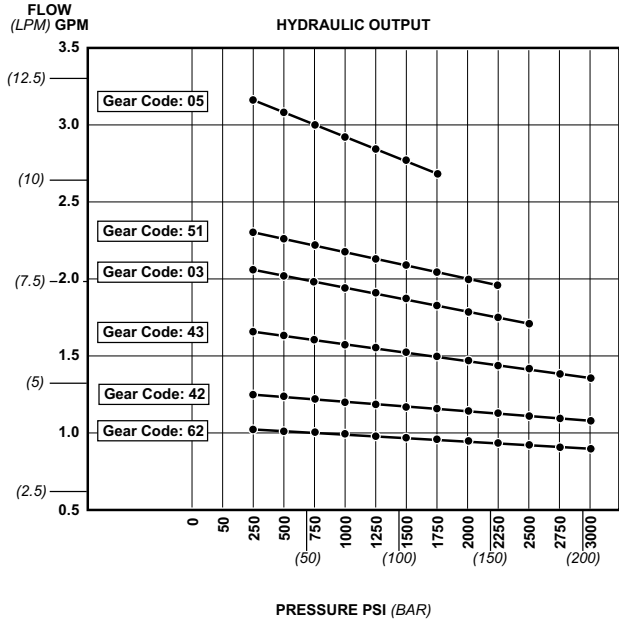

36 Volt D.C. Performance Curves

Voltage = 36.5 - .03 x AMPS

Test Fluid = Mobil D.T.E. 24
 @ 100°F (SUS 160)
 34°C (CST 34)

Performance Curve AF

SAE A Pumps

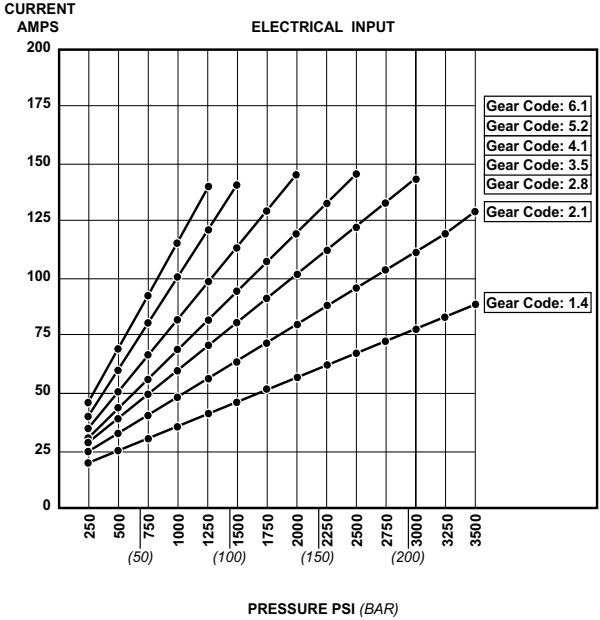
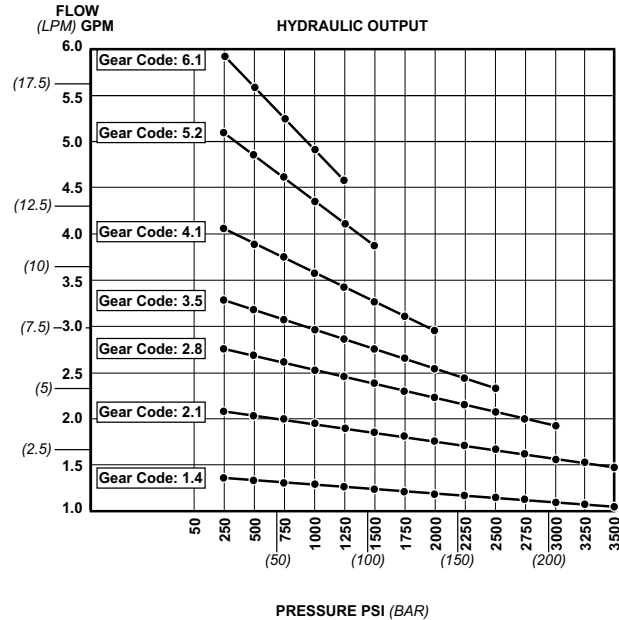



Monarch D.C. Hydraulic Power Systems

36 Volt D.C. Performance Curves

Voltage = $36.5 - .03 \times \text{AMPS}$

Test Fluid = Mobil D.T.E. 24
 @ 100°F (SUS 160)
 34°C (CST 34)

Performance Curve AG

SAE A Pumps

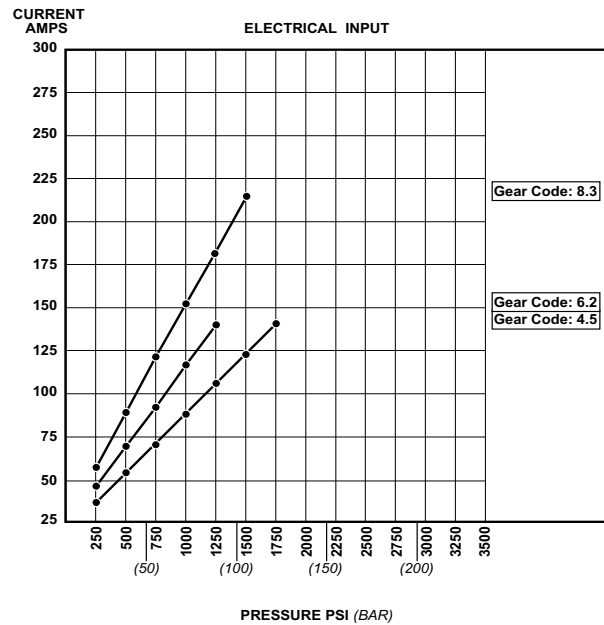
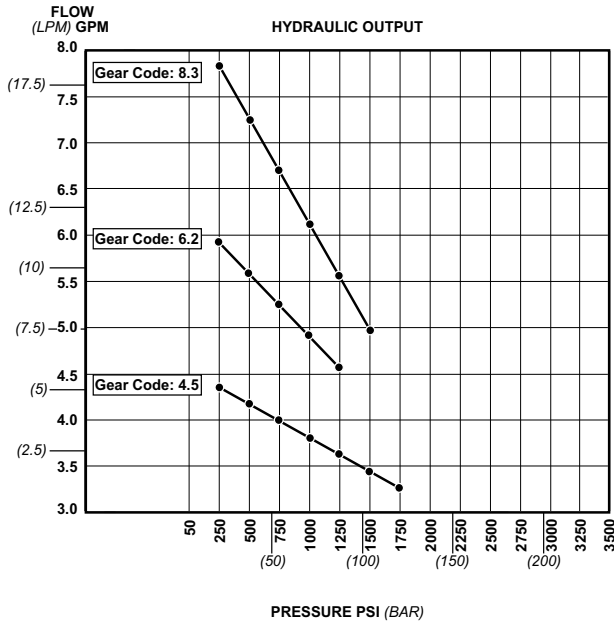

48 Volt D.C. Performance Curves

Voltage = $48.5 - .03 \times \text{AMPS}$

Test Fluid = Mobil D.T.E. 24
 @ 100°F (SUS 160)
 34°C (CST 34)

Performance Curve AH

SAE AA Pumps

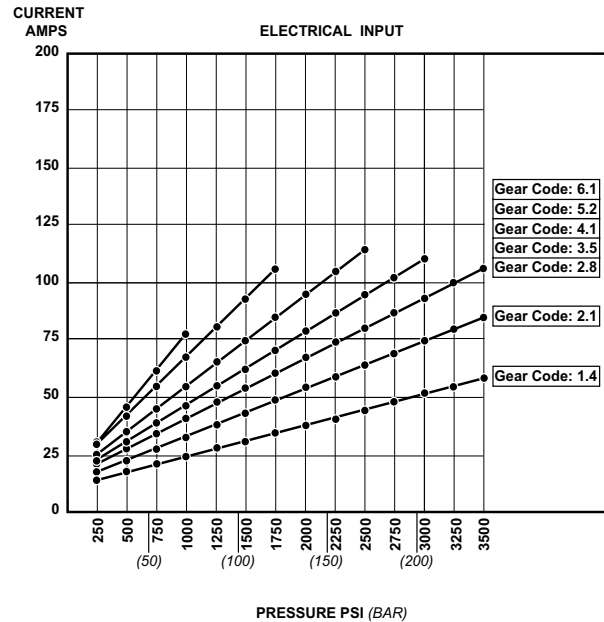
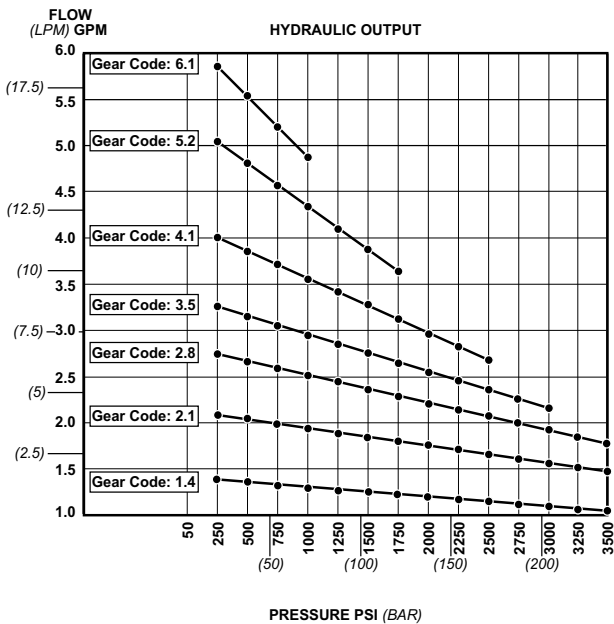

48 Volt D.C. Performance Curves

Voltage = $48.5 - .03 \times \text{AMPS}$

Test Fluid = Mobil D.T.E. 24
 @ 100°F (SUS 160)
 34°C (CST 34)

Performance Curve AI

SAE A Pumps

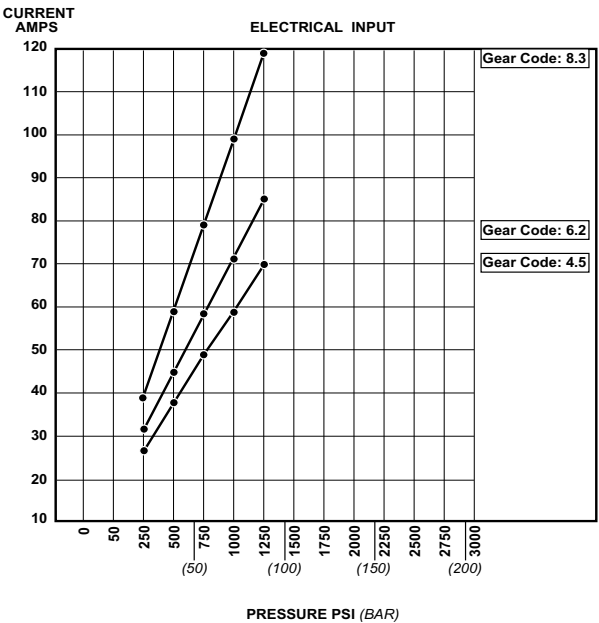
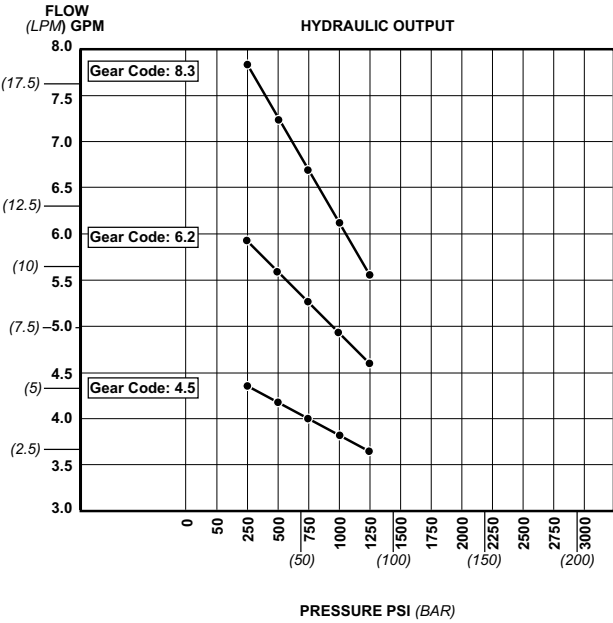

72 Volt D.C. Performance Curves

Voltage = $72.4 - .04 \times \text{AMPS}$

Test Fluid = Mobil D.T.E. 24
 @ 100°F (SUS 160)
 34°C (CST 34)

Performance Curve AJ

SAE AA Pumps

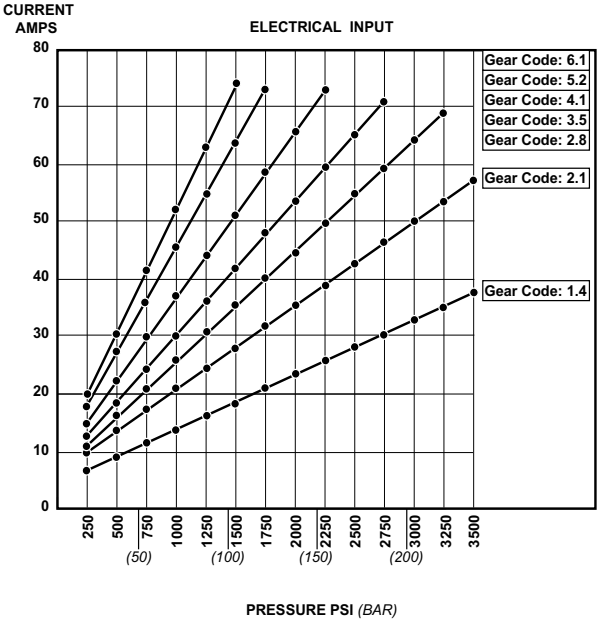
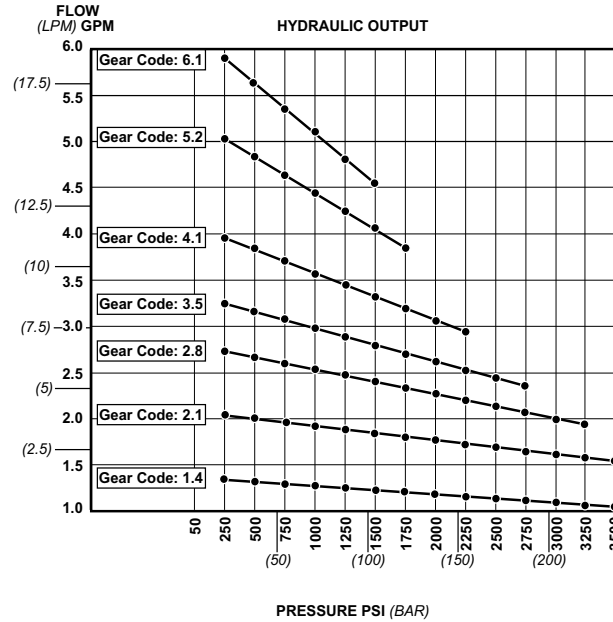



Monarch D.C. Hydraulic Power Systems

72 Volt D.C. Performance Curves

Voltage = $72.4 - .04 \times \text{AMPS}$

Test Fluid = Mobil D.T.E. 24
 @ 100°F (SUS 160)
 34°C (CST 34)

Performance Curve AK

SAE A Pumps

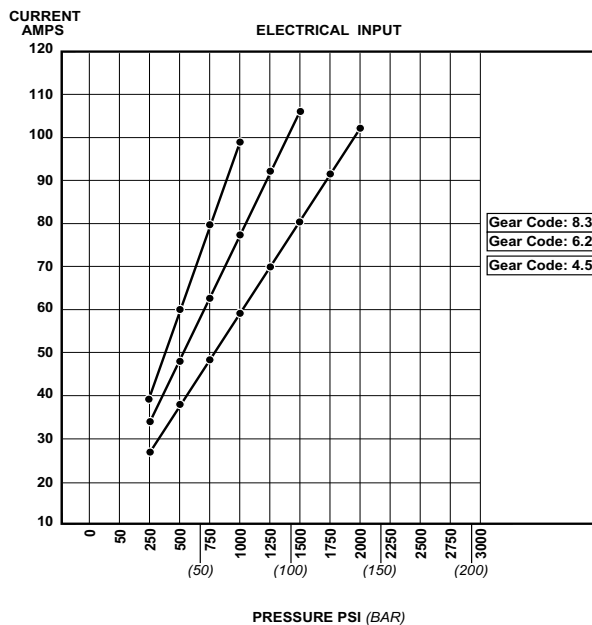
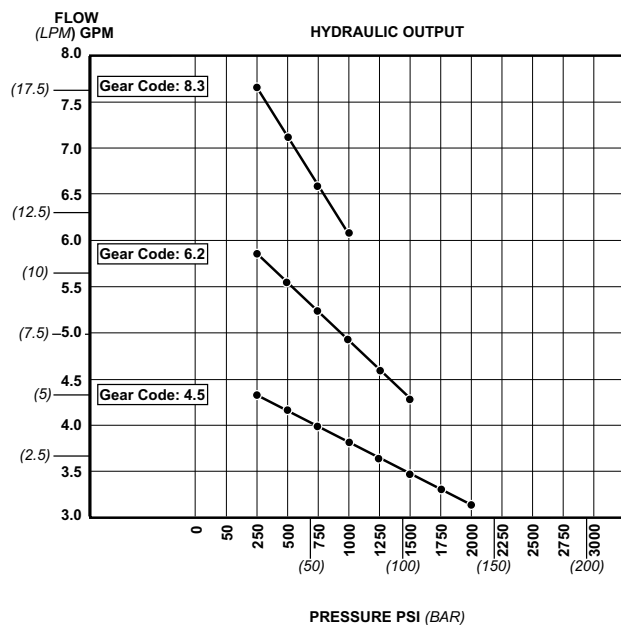

How to Order Monarch S-326 Pump/Motor Units

Please select from the following options:

MODEL S-326-			
SAE PUMP SIZE	PUMP CODE	MOTOR	VOLTAGE
AA	1.4	08164	12
	2.1	08166	24
	2.8	08169	36
	3.5	08171	48
	4.1	08175	72
	5.2		
	6.1		
A	4.5	08167	24
	6.2	08170	36
	8.3	08172	48
		08176	72

Example: **S-326-AA-2.8-08166-24** is an SAE AA 2.8 Pump (0.166 in³/rev) attached to a 24V D. C. Permanent Magnet Motor.



M Series D.C. Pump Data

PUMP CODE	DISPLACEMENT
	In ³ /Rev (Cm ³ /Rev)
12637 - 100 (New)	0.022 (0.361)
12637 - 120 (71)	0.027 (0.443)
12637 - 150 (72)*	.032 (.524)
12637 - 190 (73)*	.042 (.690)
12637 - 270 (62)*	.057 (.934)
12171 - 150 (42)	.077 (1.26)
12171 - 200 (43)	.099 (1.66)
12171 - 250 (03)	0.125 (2.13)
12171 - 270 (51)	0.137 (2.31)
12171 - 330 (New)	0.168 (2.76)
12171 - 380 (05)	0.193 (3.23)
* denotes <i>i</i> - Pump	

Recommended Operating Conditions for M Series Pumps:

Operating Temperature: -20°F to 130°F (-29°C to 54°C)

Oil Viscosity:

Optimum 100 to 350 SUS (Cst = .22 x SUS - 135/SUS)

Minimum 100 SUS at Operating
Maximum Start Up 4000 SUS

Recommended Fluid for indoor use:

Mobil DTE 24 or equal

Recommended Fluid for outdoor use:

ATF Dexron II or equal

STANDARD PUMP FEATURES:

- Fixed Displacement, External Tooth Gears
- Hardcoat Processed Internal Pump Surfaces Extend Service Life
- Extremely Tolerant of Fluid Contaminants and Resistant to Galling Caused by Low Temperature Start-up
- Wide Temperature and Viscosity Operation
- Cost Effective
- Thrust Ball on Drive Shaft Minimizes Axial Thrust Effects

Monarch Birotational Hydraulic Power Systems

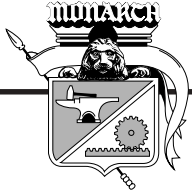

Birotational *i* - Pump

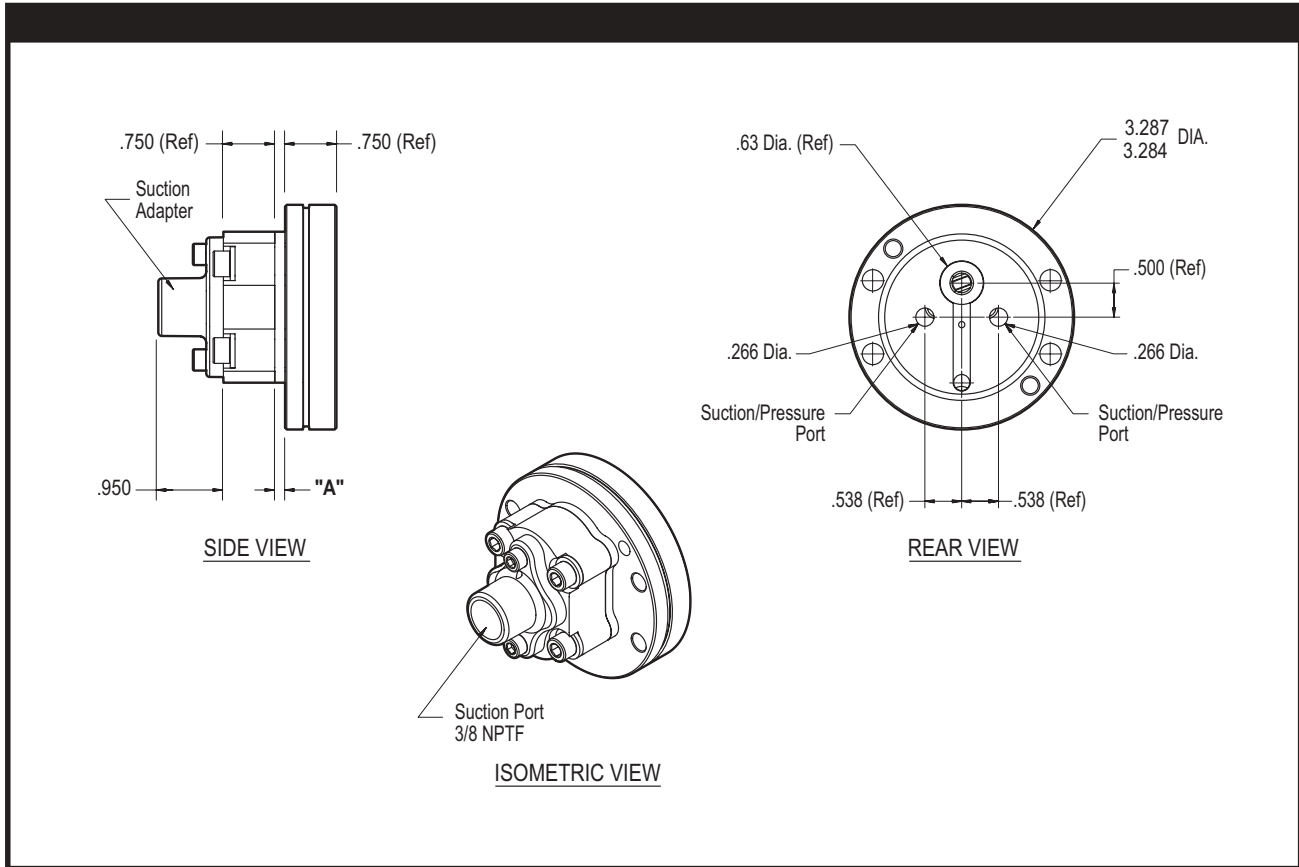

Bi-Rotational *i* - Pump Data

Pump Number	"A"	Displacement (in ³ /Rev)	Displacement (cc/Rev)	Flow @ 1800 rpm (GPM)
12818-100	.100	0.022	0.36	0.17
12818-120	.120	0.027	0.44	0.21
12818-150	.150	0.032	0.52	0.25

MODEL M-3204

Description:

- Birotational Pump and Motor/Reservoir
- Check Valves
- Externally Adjustable Relief Valves
- #6 SAE Outlets
- Horizontal Mounting

Popular Options:

- Check Valves in C1 and C2 Ports for Optional Manifold
- Vertical Mounting

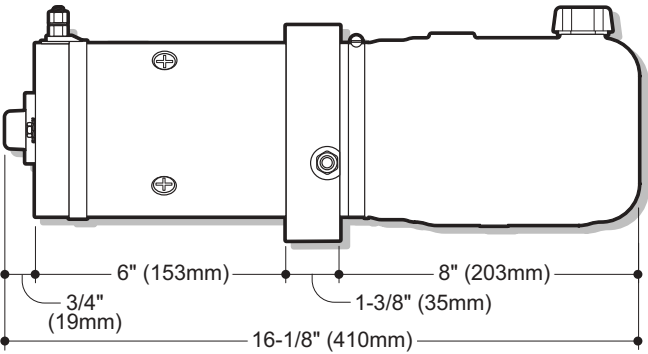
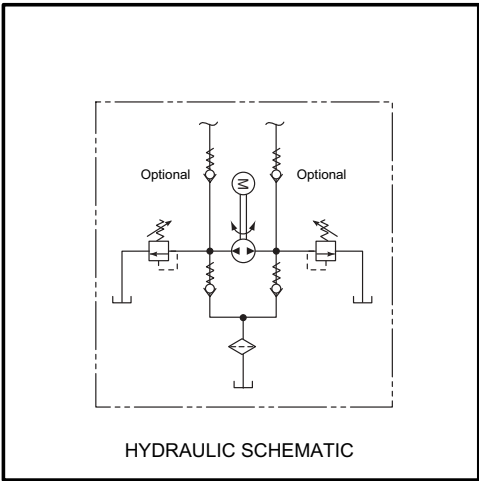

SIDE VIEW

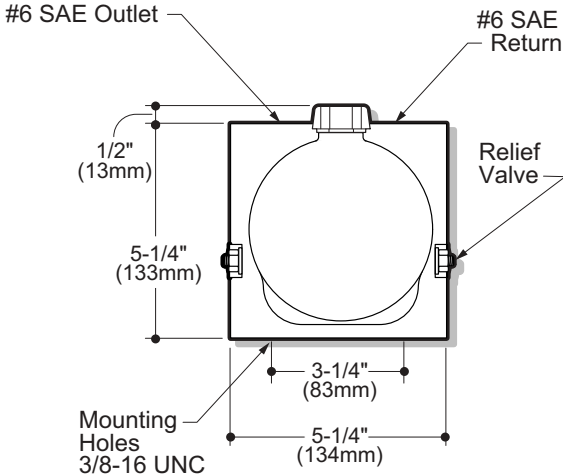

END VIEW

Consult factory for additional options and specifications.

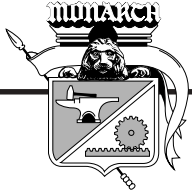

MODEL M-3230

Description:

- Birotational Pump and Motor/Reservoir
- Check Valves
- Pilot-Operated Check Valves
- Externally Adjustable Relief Valves
- #6 SAE Outlets
- Horizontal Mounting

Popular Options:

- Pressure Compensated Flow Controls
- Vertical Mounting

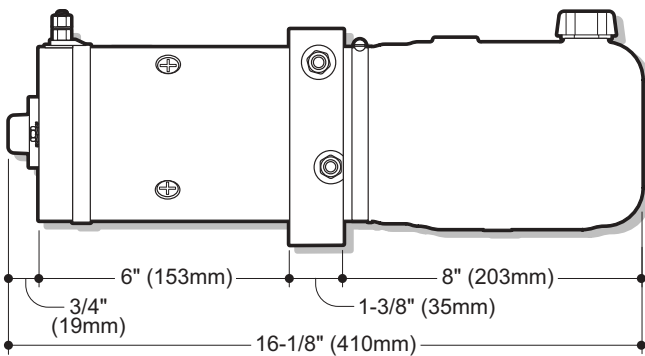
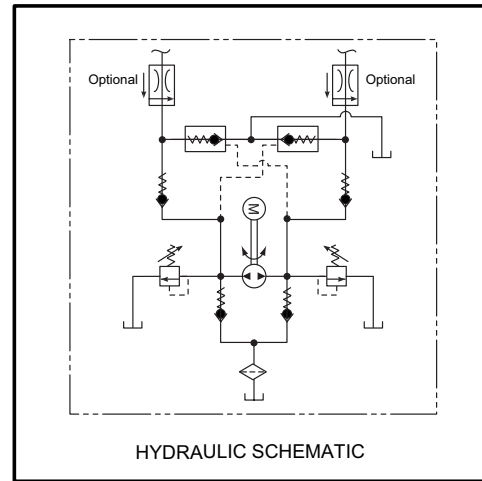

SIDE VIEW

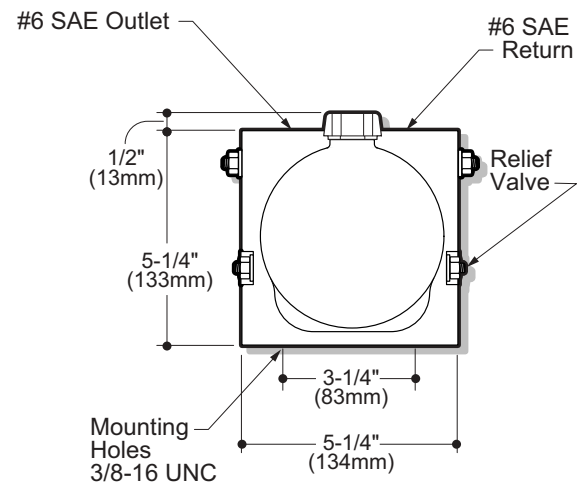

END VIEW

Consult factory for additional options and specifications.

MODEL M-3247

Description:

- Birotational Pump and Motor/Reservoir
- 2 x 2-Way/2 Position Solenoid Controlled Cartridge Valves Located Externally and Manifolded Directly to Unit.
- Check Valves
- Externally Adjustable Relief Valves
- #6 SAE Outlets
- Horizontal Mounting

Popular Options:

- Pressure Compensated Flow Controls
- Vertical Mounting

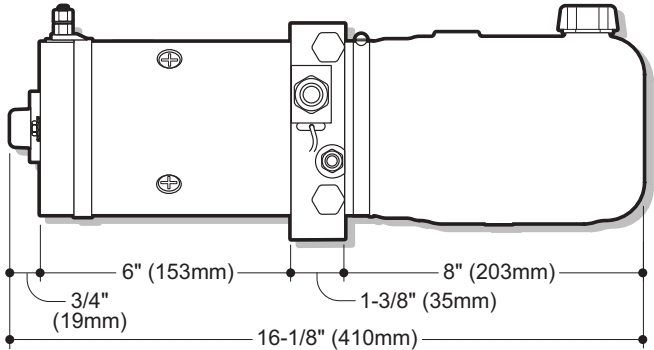
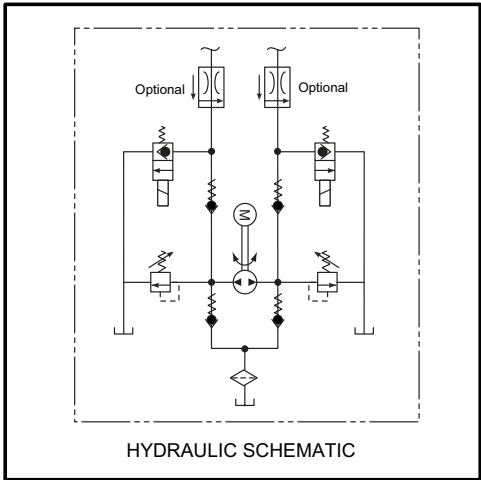

SIDE VIEW

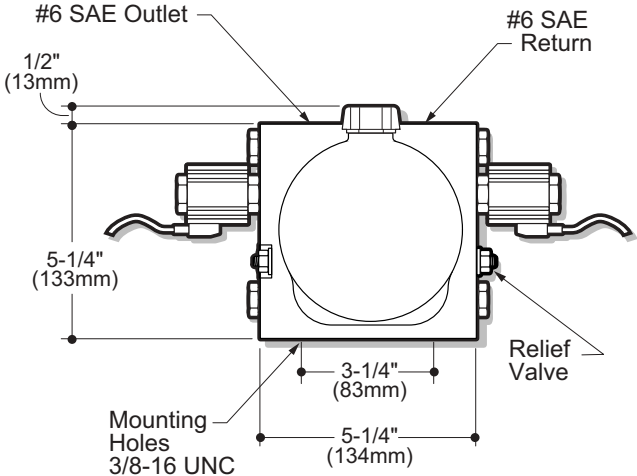

END VIEW

Consult factory for additional options and specifications.

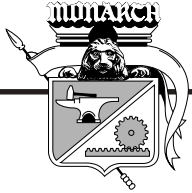

Dimensional Information for Standard D.C. Motors w/Performance Curves

M Series D.C. Motor Information

PART NUMBER	VOLTAGE	INSULATION CLASS	DIMENSIONS PAGE	NUMBER OF TERMINALS	HOUSING DIAMETER INCH (MM)	UL LISTED	DESCRIPTION *SEE KEY
08053	12	A	62.0	1	3" (77mm)	NO	PM/ID
08111-D	12	B	63.0	1	4.5" (115mm)	NO	SW/ID
08111-E	12	B	63.0	1	4.5" (115mm)	NO	SW/ID
08058	12	B	64.0	1	4.5" (115mm)	NO	SW/ID Ball Bearing Commutator End
08112	12	B	65.0	1	4.5" (115mm)	NO	CW/ID
08117	12	B	66.0	2	4.5" (115mm)	YES	SW/ID
08100	12	B	67.0	1	4.5" (115mm)	NO	SW/HD
08050	12	H	68.0	2	5.5" (140mm)	YES	SW/ED
08163	12	H	69.0	2	4.6" (117mm)	NO	PM/ID
08164	12	H	70.0	2	5.75" (146mm)	NO	PM/ID
08045	12	B	71.0	1	4.5" (115mm)	NO	SW/ID
08056	12	H	72.0	2	4.5" (115mm)	YES	SW/ID
08030	24	B	73.0	2	4.5" (115mm)	NO	SW/ID
08004	12	F	74.0	1	3.25" (83mm)	NO	PM/ID
08189	12	F	75.0	1	4.5" (115mm)	NO	SW/ID
08051	24	A	76.0	2	3" (77mm)	NO	PM/ID
08120	24	B	77.0	2	4.5" (115mm)	YES	SW/ID
08035	24	H	78.0	2	4.6" (117mm)	NO	PM/ID
08066	12	H	79.0	2	5.5" (140mm)	NO	SW/HD
08195	24	F	80.0	1	3.25" (83mm)	NO	PM/ID
08168	36	H	81.0	2	4.6" (117mm)	NO	PM/ID
08055	36	B	82.0	2	4.5" (115mm)	NO	SW/ID
08040	48	H	83.0	2	4.6" (117mm)	NO	PM/ID
08055	48	B	84.0	2	4.5" (115mm)	NO	SW/ID
08174	72	H	85.0	2	4.6" (117mm)	NO	PM/ID

Key to Abbreviations:

PM = Permanent Magnet
ID = Intermittent Duty

SW = Series Wound
ED = Extended Duty

CW = Compound Wound
HD = Heavy Duty

LD = Light Duty

A Thermal Protection Switch is available as an option on most motors and must be used with a solenoid motor start switch. Refer to the Thermal Chart on Page 86.0 for Motor Thermal Performance Data.



08053 D.C. Motor Information

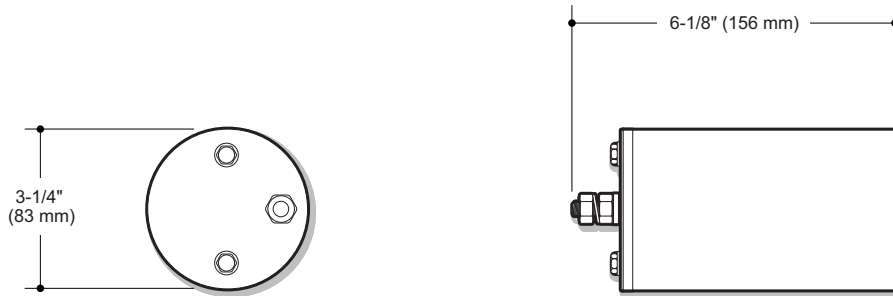

12 Volt D.C. Performance Curves Voltage = 12.3 - $\sqrt{\frac{\text{AMP} - 70}{43}}$ Test Fluid = Mobil D.T.E. 24 @ 100°F (SUS 160) 34°C (CST 34)

Performance Curves for 08053 Motor

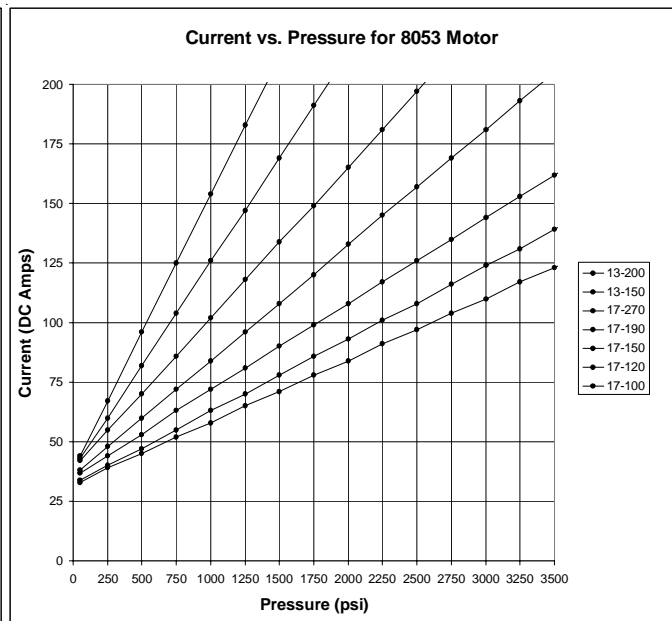
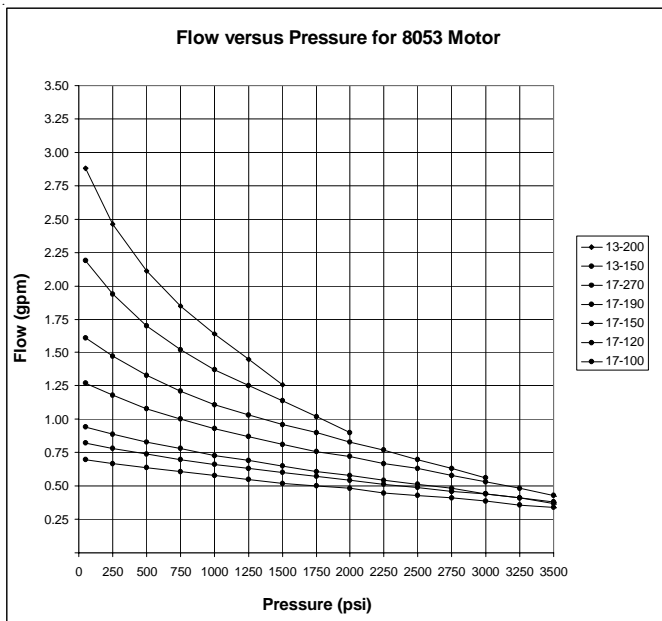

PART NUMBER	VOLTAGE	INSULATION CLASS	NUMBER OF TERMINALS	UL LISTED	DESCRIPTION *SEE KEY
08053	12	A	2	NO	PM/ID

Key to Abbreviations:

PM = Permanent Magnet
ID = Intermittent Duty

SW = Series Wound
CW = Compound Wound

ED = Extended Duty

HD = Heavy Duty

A Thermal Protection Switch is available as an option on most motors and must be used with a solenoid motor start switch. Refer to the Thermal Chart on Page 86.0 for Motor Thermal Performance Data.

08111 D.C. Motor Information

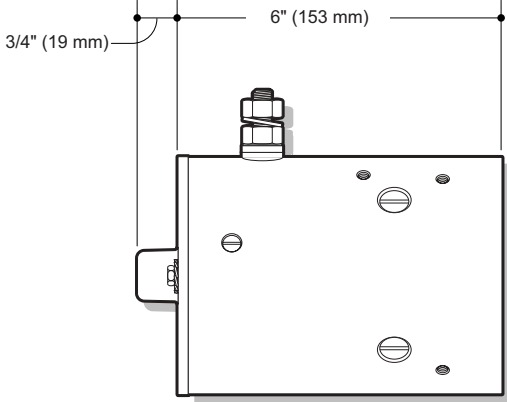
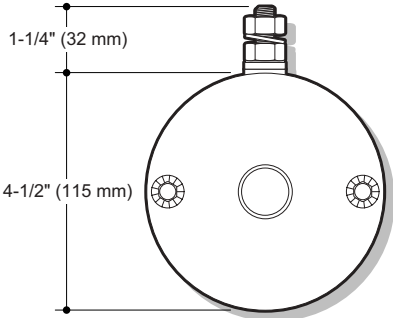

12 Volt D.C. Performance Curves

Voltage = 12.3 - $\sqrt{\frac{AMP - 70}{43}}$

Test Fluid = Mobil D.T.E. 24
@ 100°F (SUS 160)
34°C (CST 34)

Performance Curves for 08111 Motor

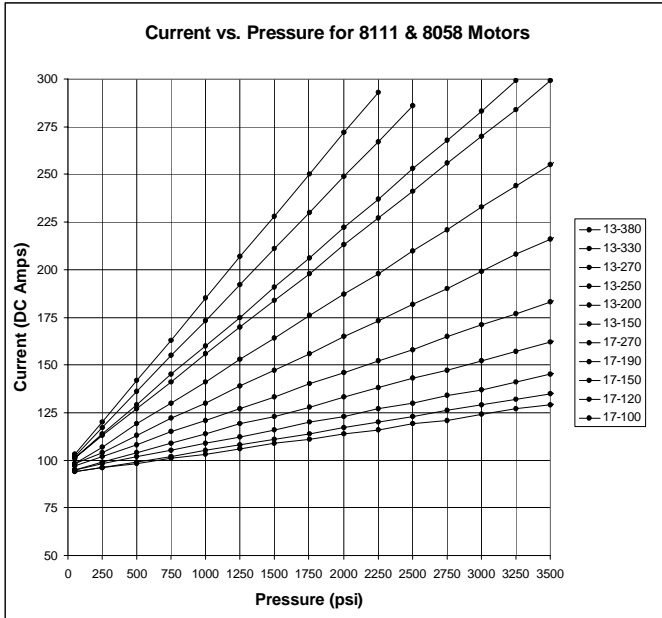
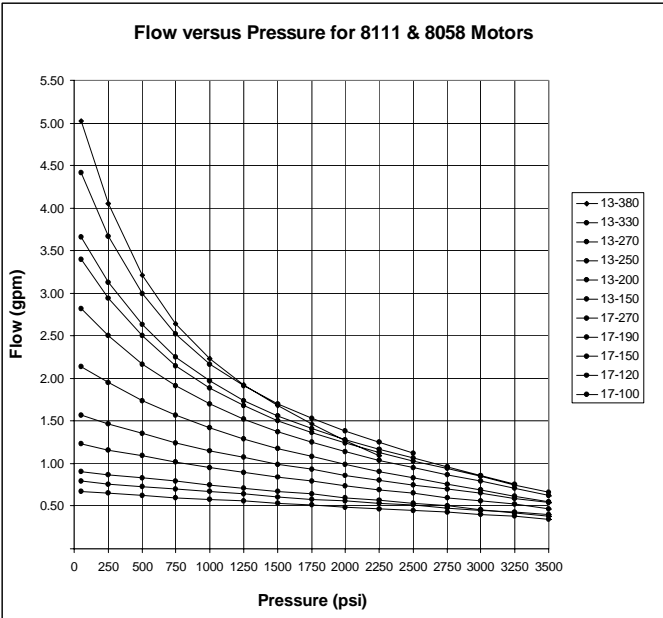

PART NUMBER	VOLTAGE	INSULATION CLASS	NUMBER OF TERMINALS	UL LISTED	DESCRIPTION *SEE KEY
08111	12	B	1	NO	SW/ID

Key to Abbreviations:
 PM = Permanent Magnet SW = Series Wound ED = Extended Duty HD = Heavy Duty
 ID = Intermittent Duty CW = Compound Wound

A Thermal Protection Switch is available as an option on most motors and must be used with a solenoid motor start switch. Refer to the Thermal Chart on Page 86.0 for Motor Thermal Performance Data.

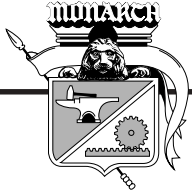

08058 D.C. Motor Information

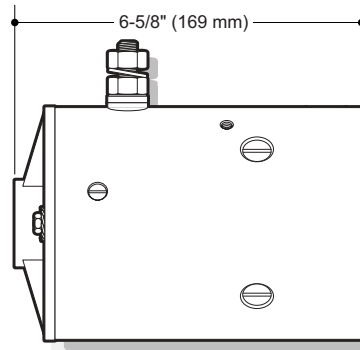
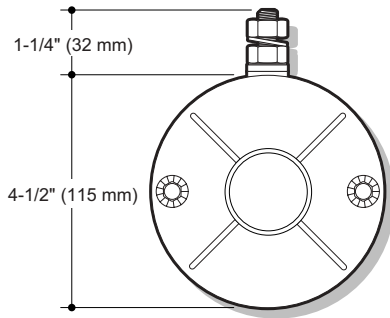

12 Volt D.C. Performance Curves

$$\text{Voltage} = 12.3 - \sqrt{\frac{\text{AMP} - 70}{43}}$$

Test Fluid = Mobil D.T.E. 24
 @ 100°F (SUS 160)
 34°C (CST 34)

Performance Curves for 08058 Motor

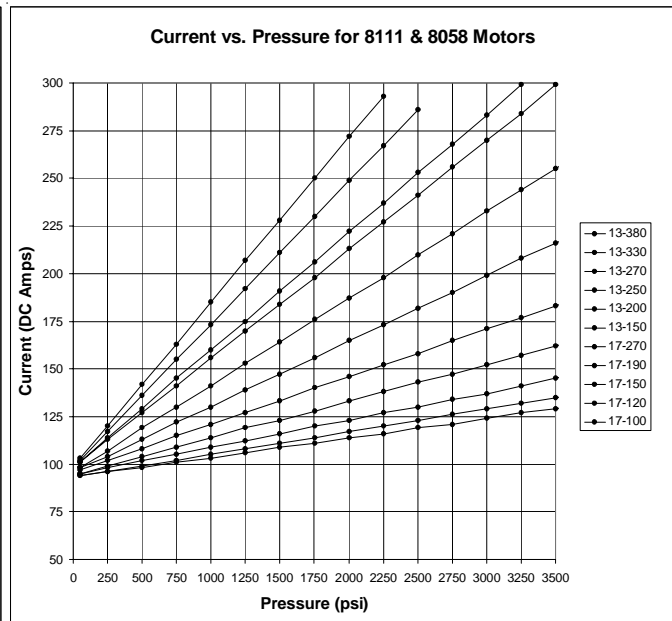
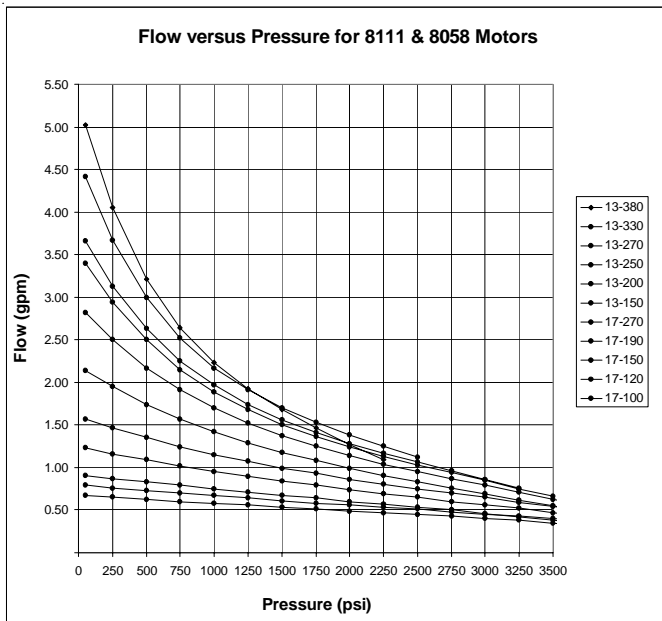

PART NUMBER	VOLTAGE	INSULATION CLASS	NUMBER OF TERMINALS	UL LISTED	DESCRIPTION *SEE KEY
08058	12	B	1	NO	SW/ID

Key to Abbreviations:

PM = Permanent Magnet
 ID = Intermittent Duty

SW = Series Wound
 CW = Compound Wound

ED = Extended Duty

HD = Heavy Duty

A Thermal Protection Switch is available as an option on most motors and must be used with a solenoid motor start switch. Refer to the Thermal Chart on Page 86.0 for Motor Thermal Performance Data.

08112 D.C. Motor Information

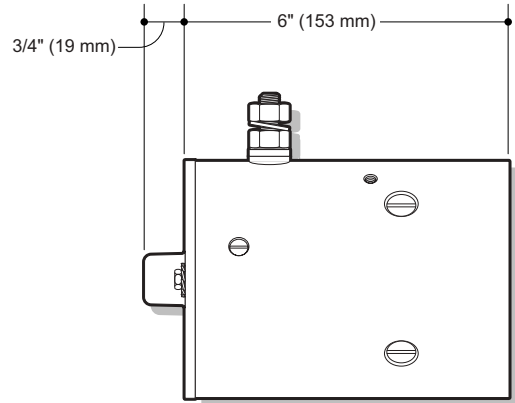
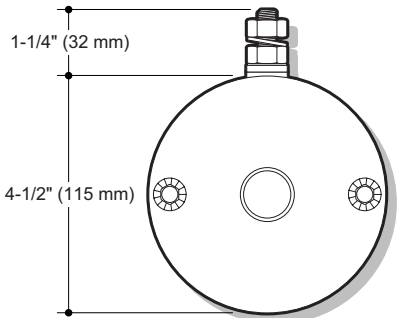

12 Volt D.C. Performance Curves Voltage = 12.3 - $\sqrt{\frac{AMP - 70}{43}}$ Test Fluid = Mobil D.T.E. 24 @ 100°F (SUS 160) 34°C (CST 34)

Performance Curves for 08112 Motor

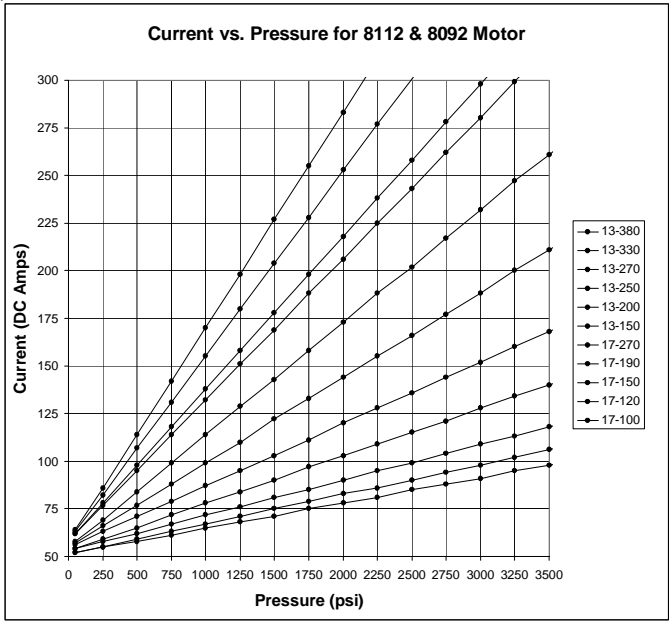
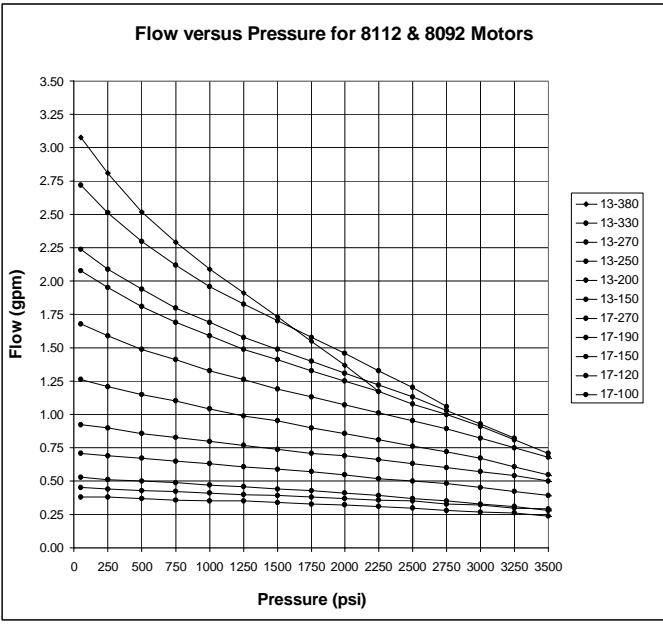

PART NUMBER	VOLTAGE	INSULATION CLASS	NUMBER OF TERMINALS	UL LISTED	DESCRIPTION *SEE KEY
08112	12	B	1	NO	CW/ID

Key to Abbreviations:
 PM = Permanent Magnet SW = Series Wound ED = Extended Duty HD = Heavy Duty
 ID = Intermittent Duty CW = Compound Wound

A Thermal Protection Switch is available as an option on most motors and must be used with a solenoid motor start switch. Refer to the Thermal Chart on Page 86.0 for Motor Thermal Performance Data.

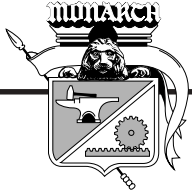

08117 D.C. Motor Information

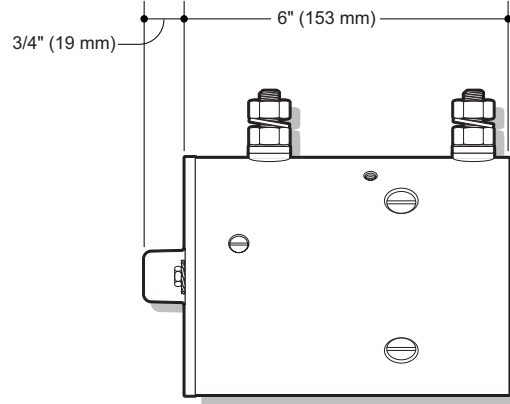
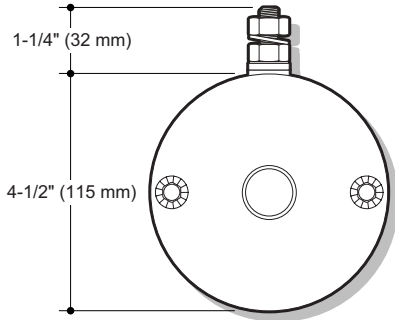

12 Volt D.C. Performance Curves

Voltage = 12.3 - $\sqrt{\frac{AMP - 70}{43}}$

Test Fluid = Mobil D.T.E. 24
@ 100°F (SUS 160)
34°C (CST 34)

Performance Curves for 08117 Motor

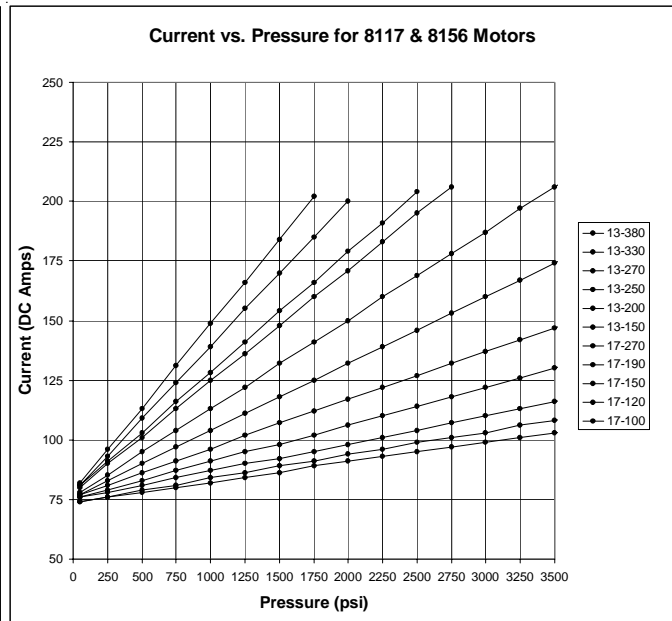
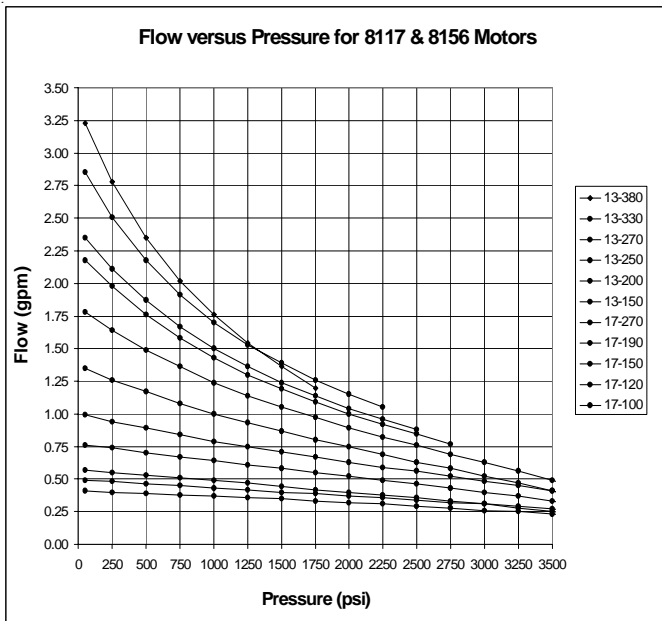

PART NUMBER	VOLTAGE	INSULATION CLASS	NUMBER OF TERMINALS	UL LISTED	DESCRIPTION *SEE KEY
08117	12	B	2	YES	SW/ID

Key to Abbreviations:

PM = Permanent Magnet
ID = Intermittent Duty

SW = Series Wound
CW = Compound Wound

ED = Extended Duty

HD = Heavy Duty

A Thermal Protection Switch is available as an option on most motors and must be used with a solenoid motor start switch. Refer to the Thermal Chart on Page 86.0 for Motor Thermal Performance Data.

08100 D.C. Motor Information

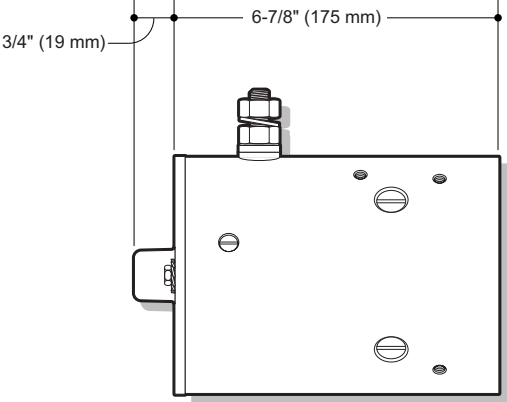
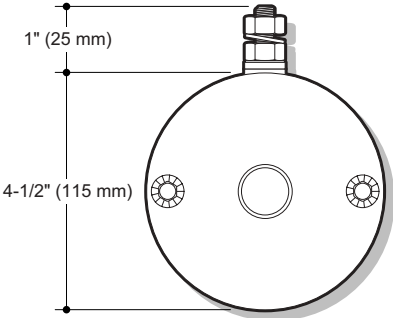

12 Volt D.C. Performance Curves

Voltage = 12.3 - $\sqrt{\frac{\text{AMP} - 70}{43}}$

Test Fluid = Mobil D.T.E. 24
@ 100°F (SUS 160)
34°C (CST 34)

Performance Curves for 08100 Motor

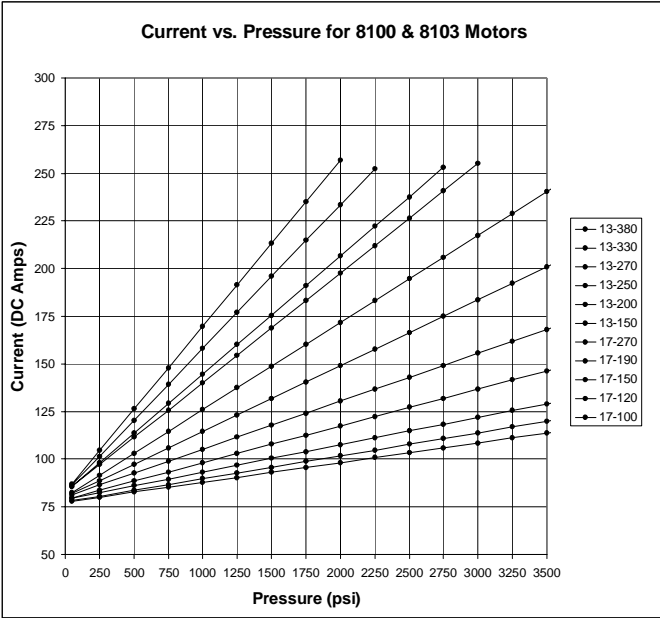
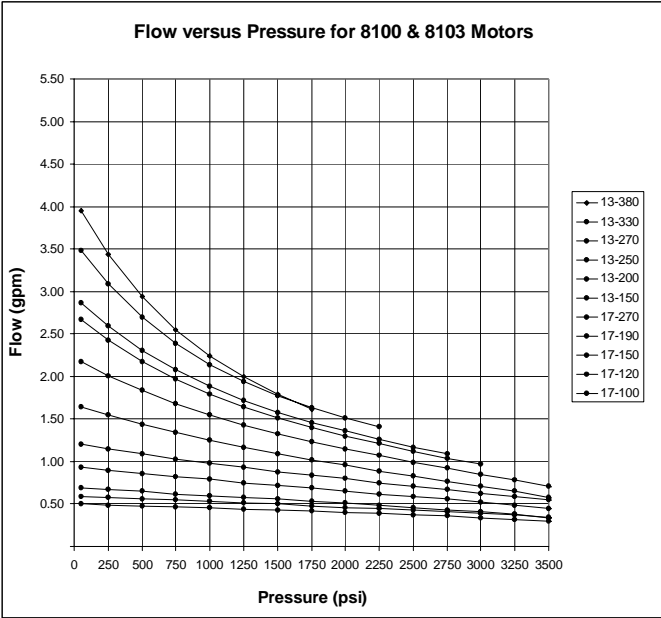

PART NUMBER	VOLTAGE	INSULATION CLASS	NUMBER OF TERMINALS	UL LISTED	DESCRIPTION *SEE KEY
08100	12	B	1	NO	SW/HD

Key to Abbreviations:
 PM = Permanent Magnet SW = Series Wound ED = Extended Duty HD = Heavy Duty
 ID = Intermittent Duty CW = Compound Wound

A Thermal Protection Switch is available as an option on most motors and must be used with a solenoid motor start switch. Refer to the Thermal Chart on Page 86.0 for Motor Thermal Performance Data.

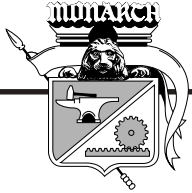

08050 D.C. Motor Information

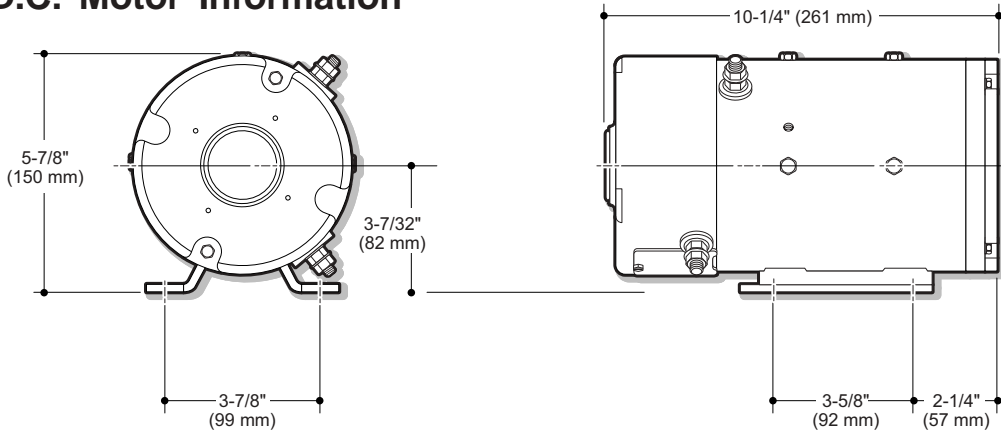

12 Volt D.C. Performance Curves

Voltage = 12.3 - $\sqrt{\frac{AMP - 70}{43}}$

Test Fluid = Mobil D.T.E. 24
 @ 100°F (SUS 160)
 34°C (CST 34)

Performance Curves for 08050 Motor

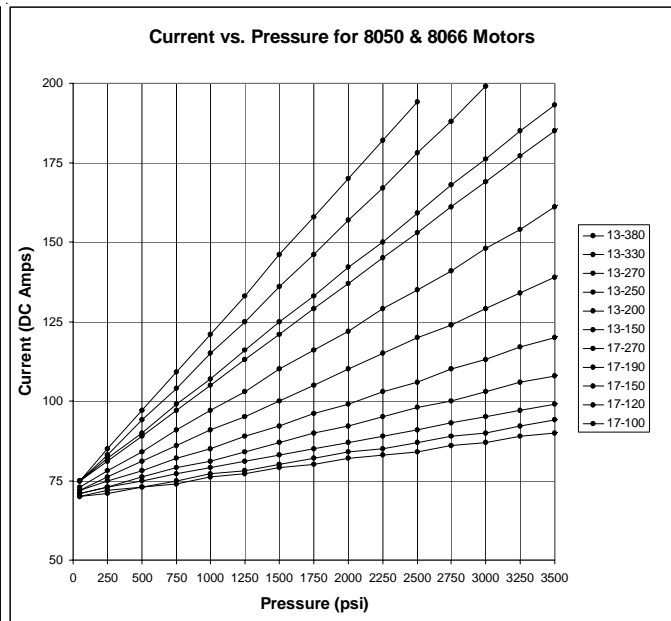
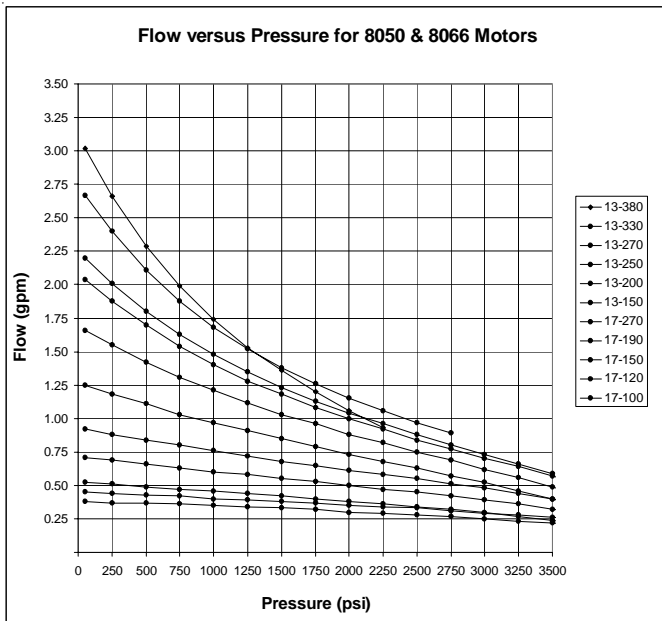

PART NUMBER	VOLTAGE	INSULATION CLASS	NUMBER OF TERMINALS	UL LISTED	DESCRIPTION *SEE KEY
08050	12	H	2	YES	SW/ED

Key to Abbreviations:

PM = Permanent Magnet
 ID = Intermittent Duty

SW = Series Wound
 CW = Compound Wound

ED = Extended Duty

HD = Heavy Duty

A Thermal Protection Switch is available as an option on most motors and must be used with a solenoid motor start switch. Refer to the Thermal Chart on Page 86.0 for Motor Thermal Performance Data.

08163 D.C. Motor Information

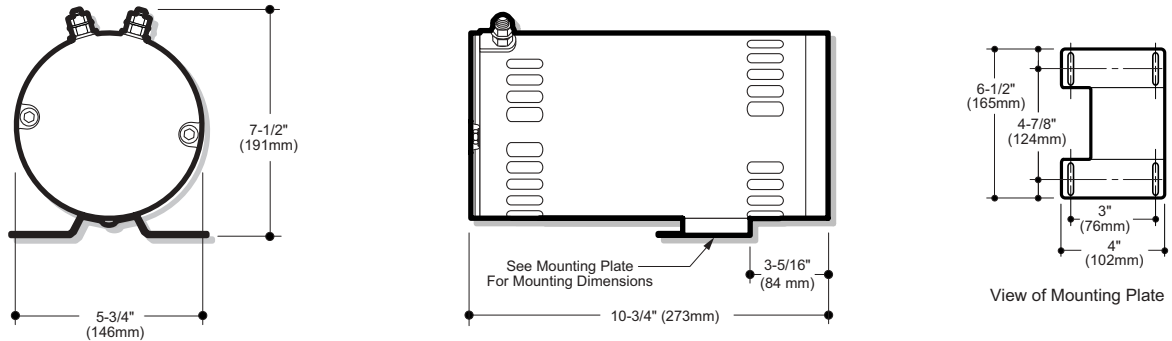

12 Volt D.C. Performance Curves

$$\text{Voltage} = 12.3 - \sqrt{\frac{\text{AMP} - 70}{43}}$$

Test Fluid = Mobil D.T.E. 24
 @ 100°F (SUS 160)
 34°C (CST 34)

Performance Curves for 08163 Motor

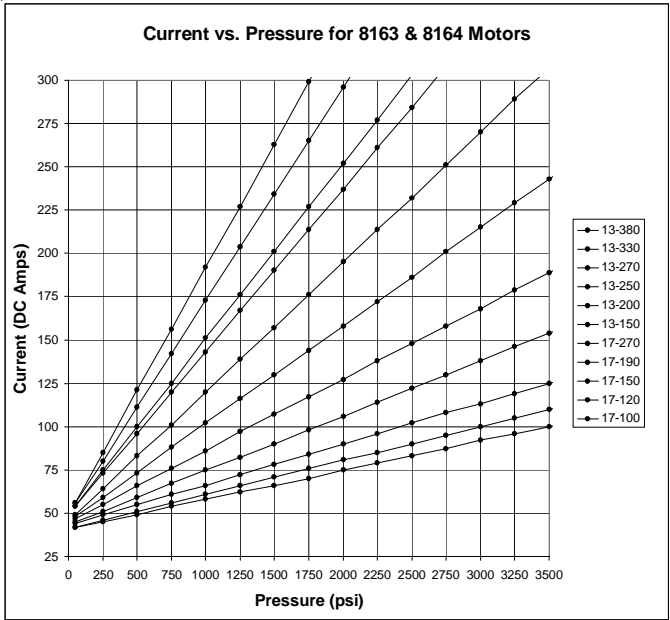
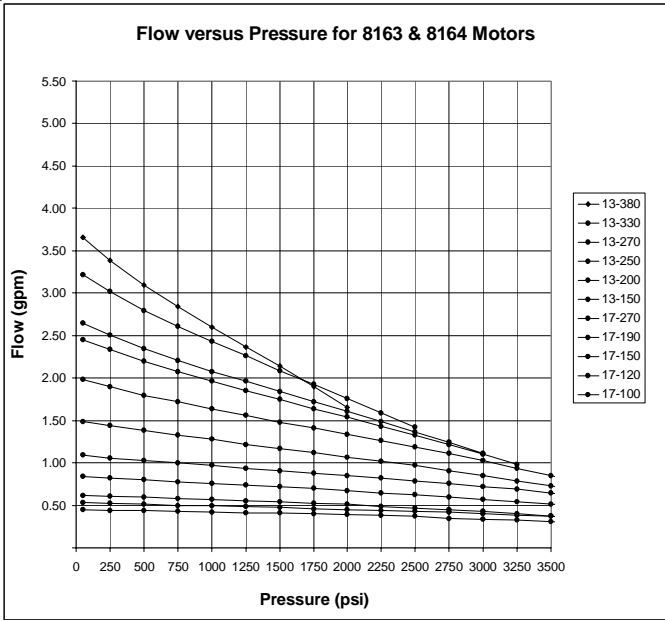

PART NUMBER	VOLTAGE	INSULATION CLASS	NUMBER OF TERMINALS	UL LISTED	DESCRIPTION *SEE KEY
08163	12	H	2	NO	PM/ID

Key to Abbreviations:
 PM = Permanent Magnet SW = Series Wound ED = Extended Duty HD = Heavy Duty
 ID = Intermittent Duty CW = Compound Wound

A Thermal Protection Switch is available as an option on most motors and must be used with a solenoid motor start switch. Refer to the Thermal Chart on Page 86.0 for Motor Thermal Performance Data.



08164 D.C. Motor Information

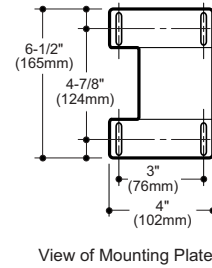
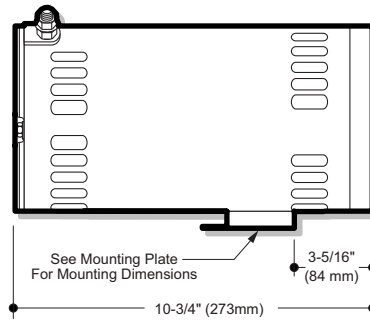
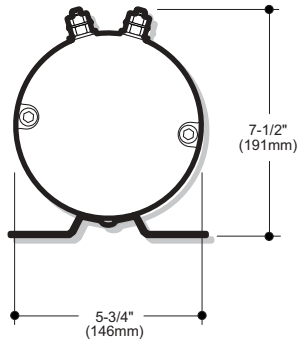

12 Volt D.C. Performance Curves

$$\text{Voltage} = 12.3 - \sqrt{\frac{\text{AMP} - 70}{43}}$$

Test Fluid = Mobil D.T.E. 24
 @ 100°F (SUS 160)
 34°C (CST 34)

Performance Curves for 08164 Motor

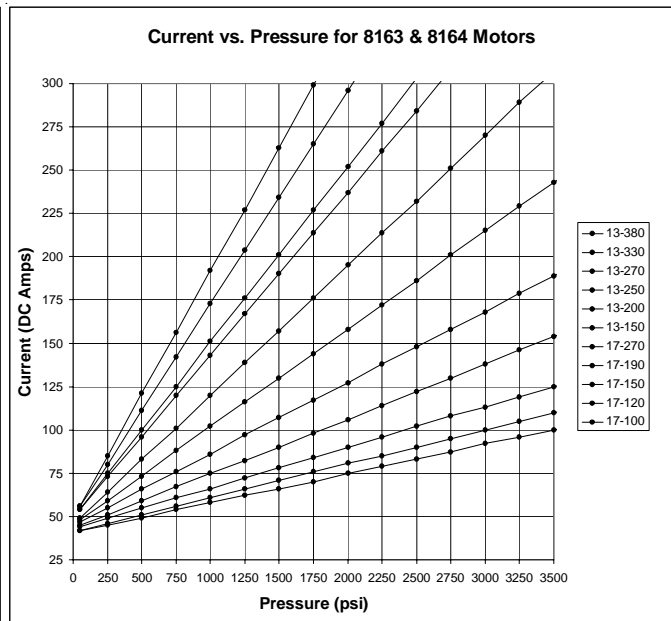
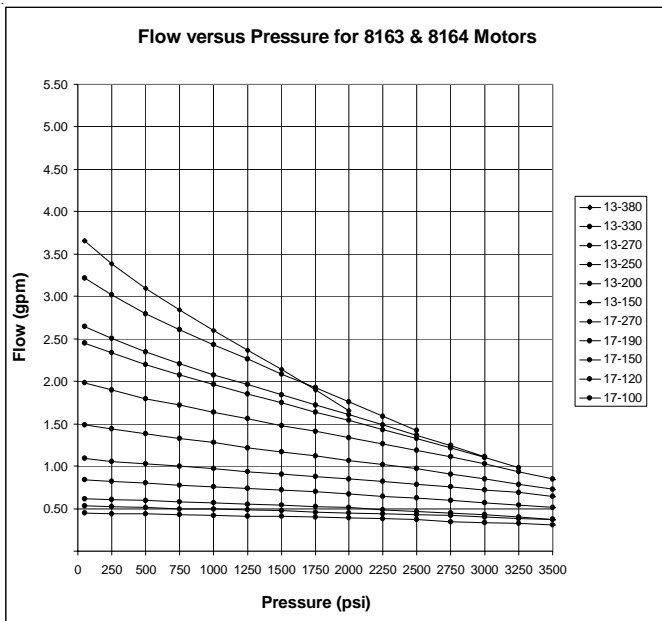

PART NUMBER	VOLTAGE	INSULATION CLASS	NUMBER OF TERMINALS	UL LISTED	DESCRIPTION *SEE KEY
08164	12	H	2	NO	PM/ID

Key to Abbreviations:

PM = Permanent Magnet
 ID = Intermittent Duty

SW = Series Wound
 CW = Compound Wound

ED = Extended Duty

HD = Heavy Duty

A Thermal Protection Switch is available as an option on most motors and must be used with a solenoid motor start switch. Refer to the Thermal Chart on Page 86.0 for Motor Thermal Performance Data.

08045 D.C. Motor Information

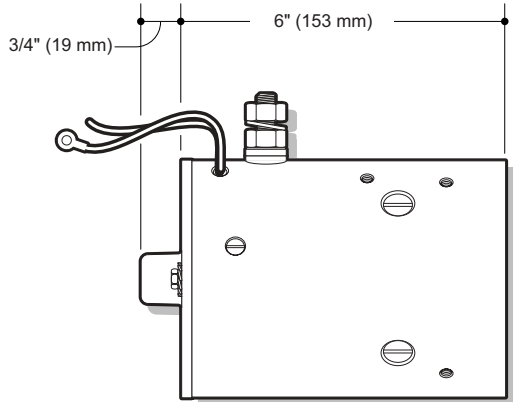
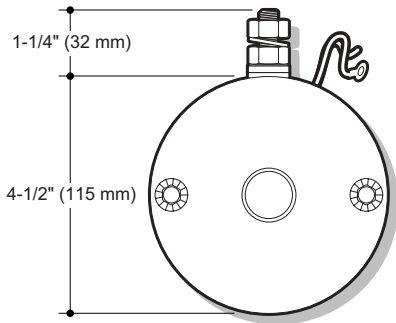

12 Volt D.C. Performance Curves Voltage = 12.3 - $\sqrt{\frac{\text{AMP} - 70}{43}}$ Test Fluid = Mobil D.T.E. 24
 @ 100°F (SUS 160)
 34°C (CST 34)

Performance Curves for 08045 Motor

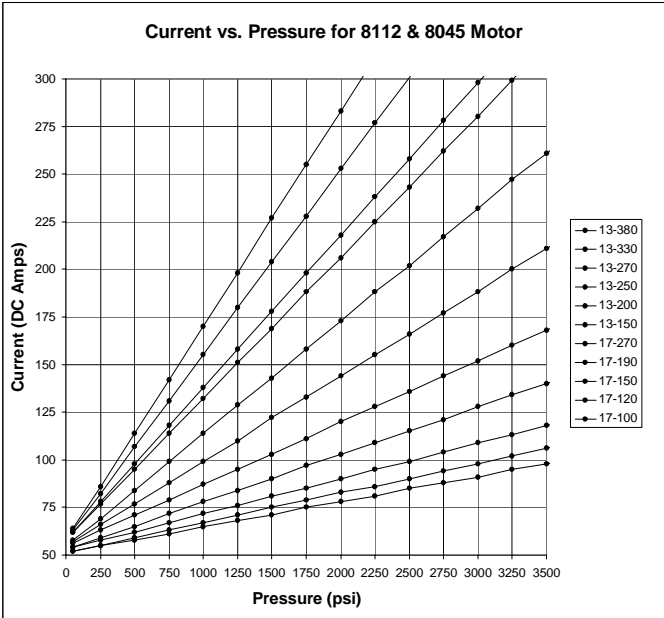
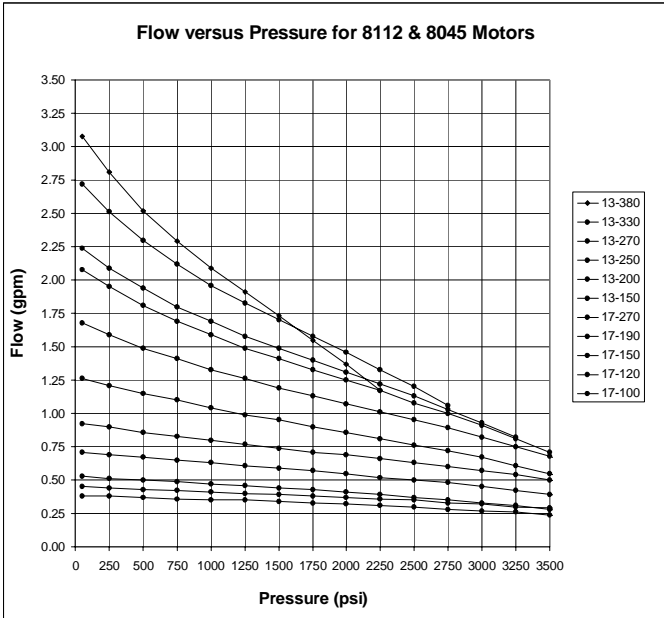

PART NUMBER	VOLTAGE	INSULATION CLASS	NUMBER OF TERMINALS	UL LISTED	DESCRIPTION *SEE KEY
08045	12	B	1	NO	SW/ID

Key to Abbreviations:
 PM = Permanent Magnet SW = Series Wound ED = Extended Duty HD = Heavy Duty
 ID = Intermittent Duty CW = Compound Wound

A Thermal Protection Switch is available as an option on most motors and must be used with a solenoid motor start switch. Refer to the Thermal Chart on Page 86.0 for Motor Thermal Performance Data.

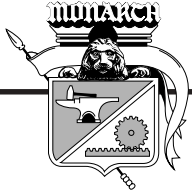

08056 D.C. Motor Information

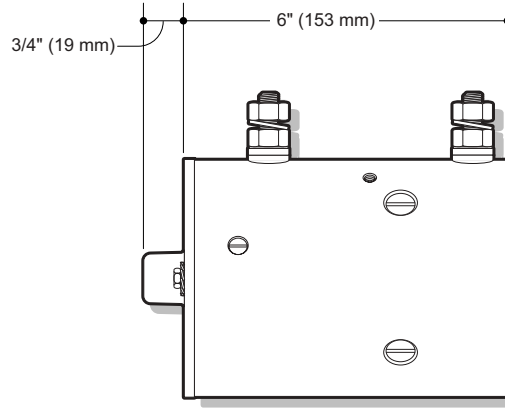
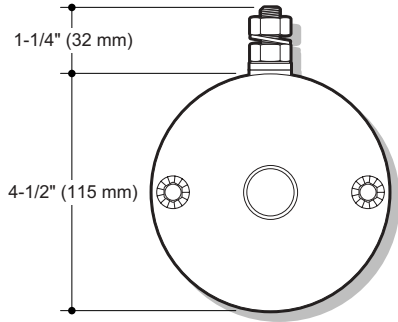

12 Volt D.C. Performance Curves

$$\text{Voltage} = 12.3 - \sqrt{\frac{\text{AMP} - 70}{43}}$$

Test Fluid = Mobil D.T.E. 24
 @ 100°F (SUS 160)
 34°C (CST 34)

Performance Curves for 08056 Motor

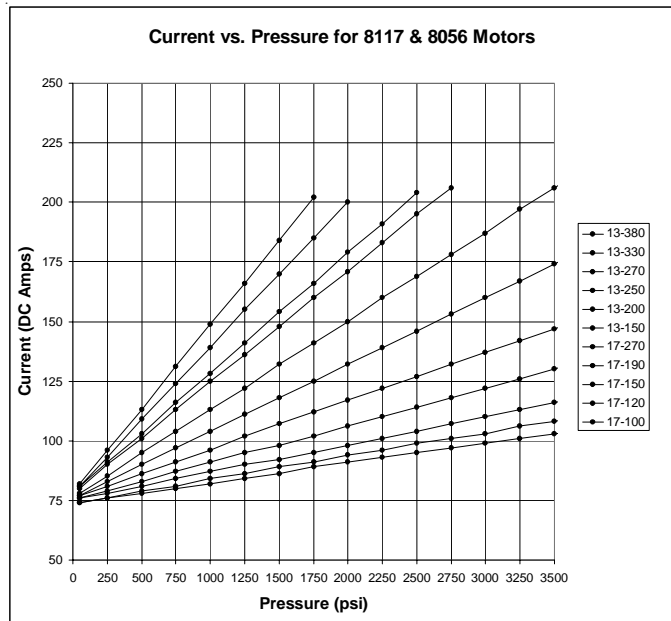
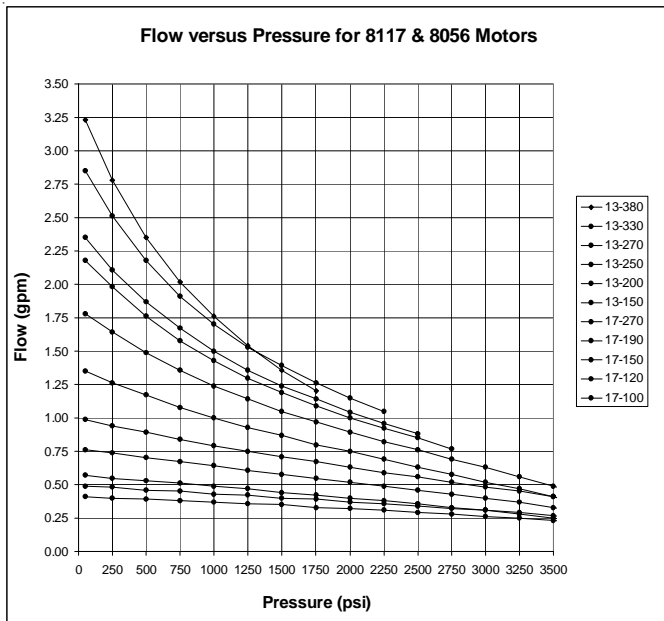

PART NUMBER	VOLTAGE	INSULATION CLASS	NUMBER OF TERMINALS	UL LISTED	DESCRIPTION *SEE KEY
08056	12	H	2	YES	SW/ID

Key to Abbreviations:

PM = Permanent Magnet
 ID = Intermittent Duty

SW = Series Wound
 CW = Compound Wound

ED = Extended Duty

HD = Heavy Duty

A Thermal Protection Switch is available as an option on most motors and must be used with a solenoid motor start switch. Refer to the Thermal Chart on Page 86.0 for Motor Thermal Performance Data.

08030 D.C. Motor Information

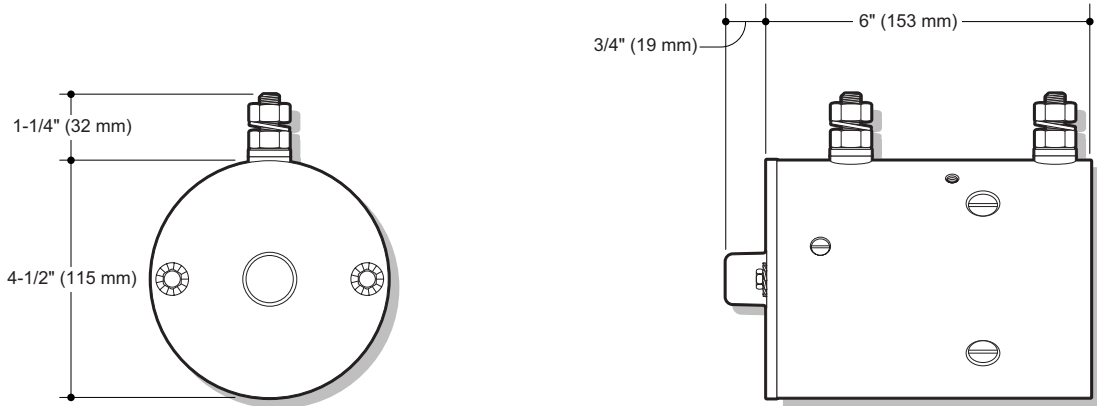

12 Volt D.C. Performance Curves

Voltage = 12.3 - $\sqrt{\frac{\text{AMP} - 70}{43}}$ Test Fluid = Mobil D.T.E. 24
 @ 100°F (SUS 160)
 34°C (CST 34)

Performance Curves for 08030 Motor

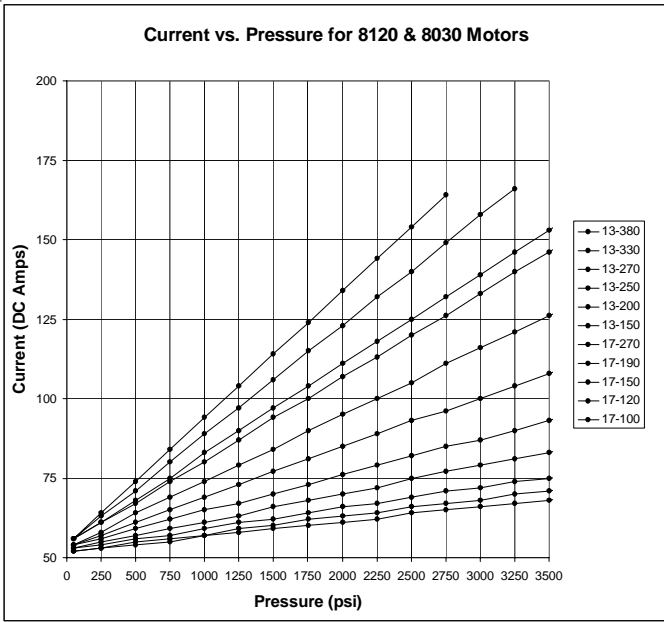
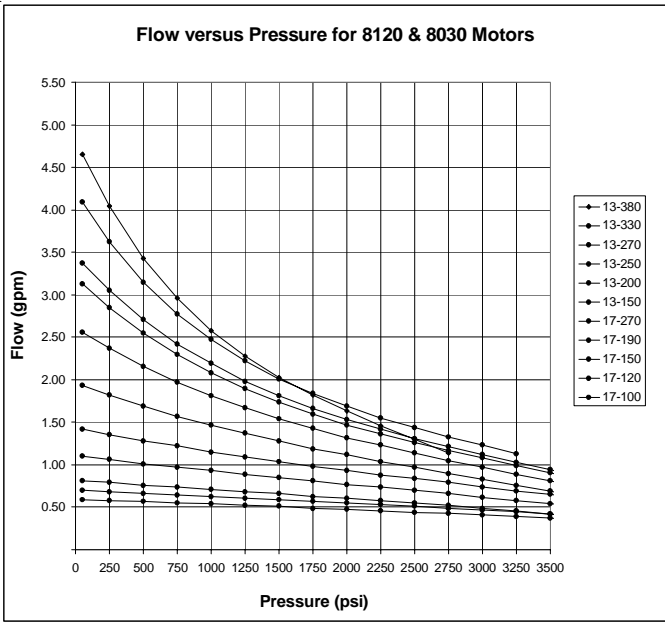

PART NUMBER	VOLTAGE	INSULATION CLASS	NUMBER OF TERMINALS	UL LISTED	DESCRIPTION *SEE KEY
08030	24	B	2	NO	SW/ID

Key to Abbreviations:
 PM = Permanent Magnet SW = Series Wound ED = Extended Duty HD = Heavy Duty
 ID = Intermittent Duty CW = Compound Wound

A Thermal Protection Switch is available as an option on most motors and must be used with a solenoid motor start switch. Refer to the Thermal Chart on Page 86.0 for Motor Thermal Performance Data.



08004 D.C. Motor Information

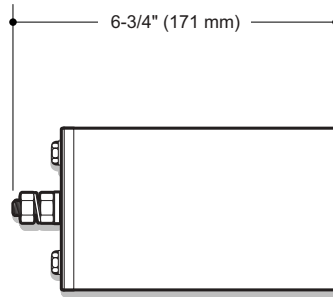
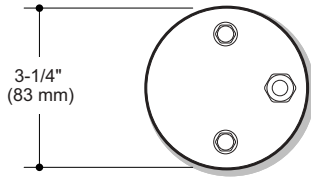

12 Volt D.C. Performance Curves

$$\text{Voltage} = 12.3 - \sqrt{\frac{\text{AMP} - 70}{43}}$$

Test Fluid = Mobil D.T.E. 24
 @ 100°F (SUS 160)
 34°C (CST 34)

Performance Curves for 08004 Motor

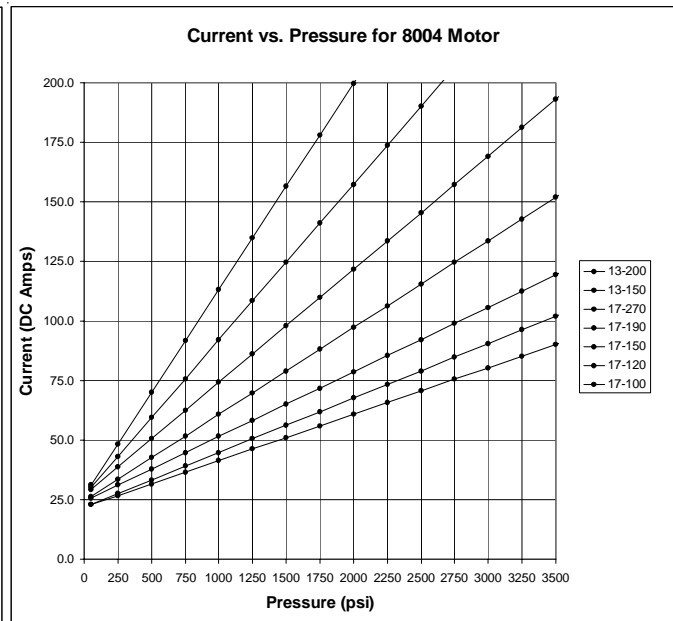
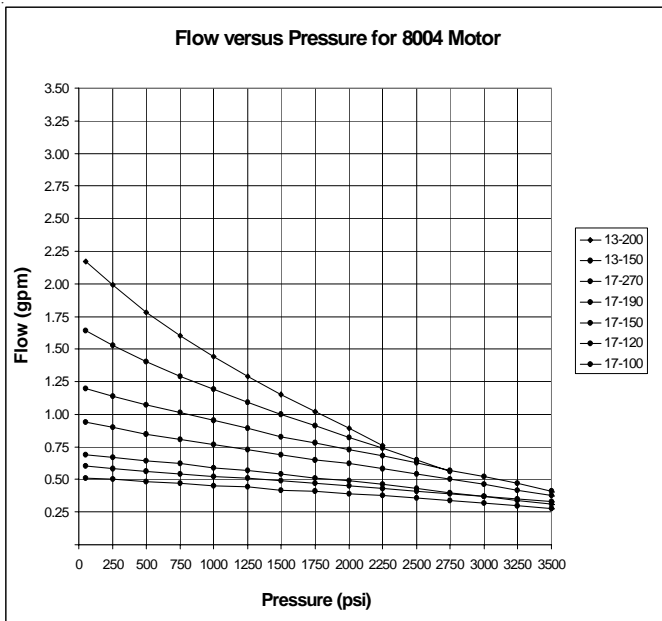

PART NUMBER	VOLTAGE	INSULATION CLASS	NUMBER OF TERMINALS	UL LISTED	DESCRIPTION *SEE KEY
08004	12	F	1	NO	PM/ID

Key to Abbreviations:

PM = Permanent Magnet
 ID = Intermittent Duty

SW = Series Wound
 CW = Compound Wound

ED = Extended Duty

HD = Heavy Duty

A Thermal Protection Switch is available as an option on most motors and must be used with a solenoid motor start switch. Refer to the Thermal Chart on Page 86.0 for Motor Thermal Performance Data.

08189 D.C. Motor Information

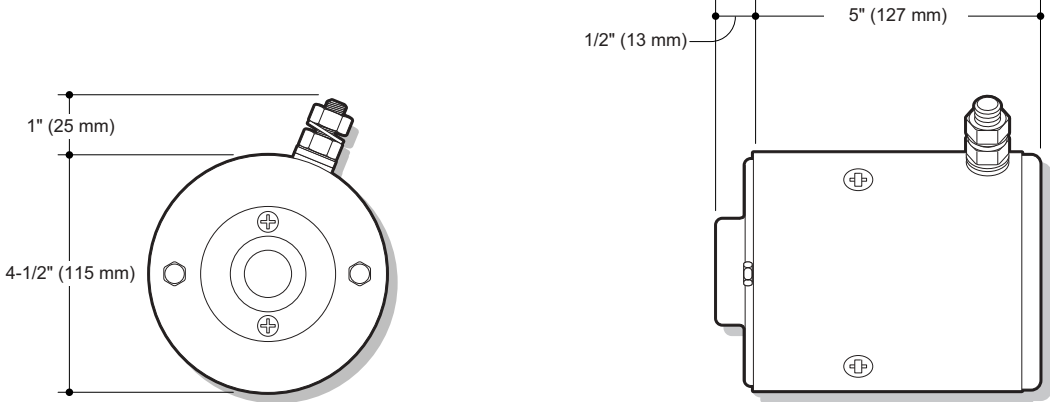

12 Volt D.C. Performance Curves Voltage = 12.3 - $\sqrt{\frac{AMP - 70}{43}}$ Test Fluid = Mobil D.T.E. 24 @ 100°F (SUS 160) 34°C (CST 34)

Performance Curves for 08189 Motor

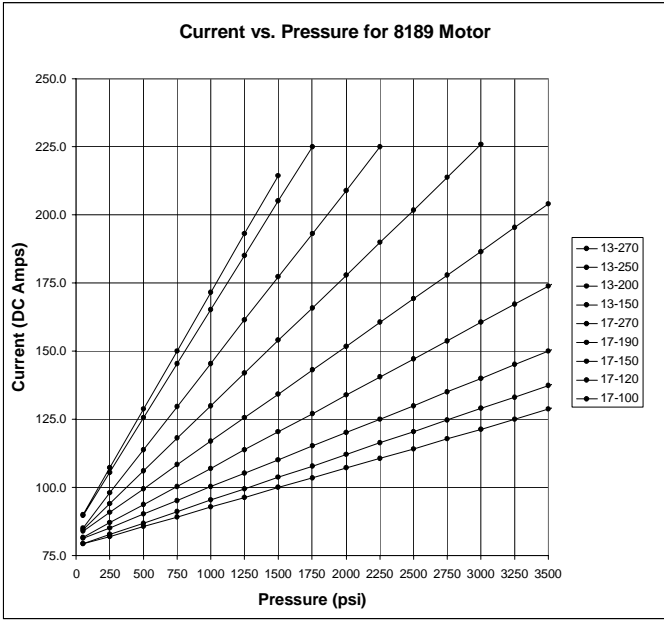
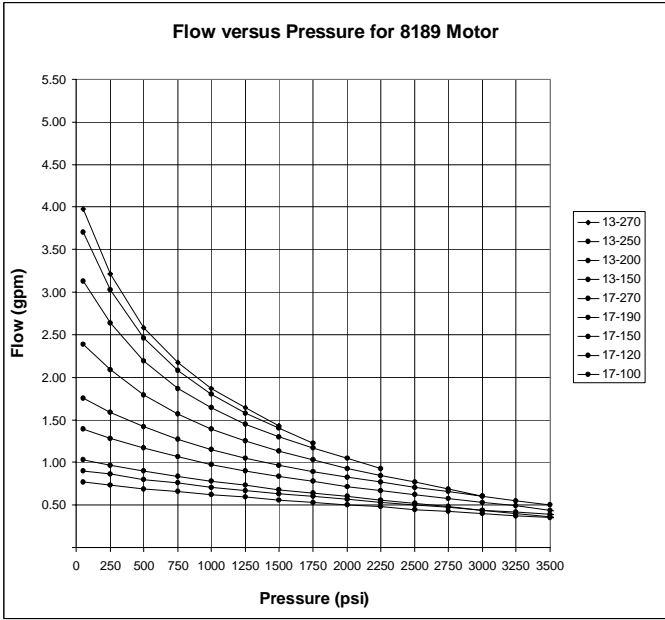

PART NUMBER	VOLTAGE	INSULATION CLASS	NUMBER OF TERMINALS	UL LISTED	DESCRIPTION *SEE KEY
08189	12	F	1	NO	SW/ID

Key to Abbreviations:
 PM = Permanent Magnet SW = Series Wound ED = Extended Duty HD = Heavy Duty
 ID = Intermittent Duty CW = Compound Wound

A Thermal Protection Switch is available as an option on most motors and must be used with a solenoid motor start switch. Refer to the Thermal Chart on Page 86.0 for Motor Thermal Performance Data.

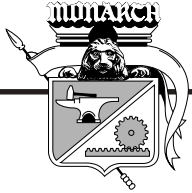

08066 D.C. Motor Information

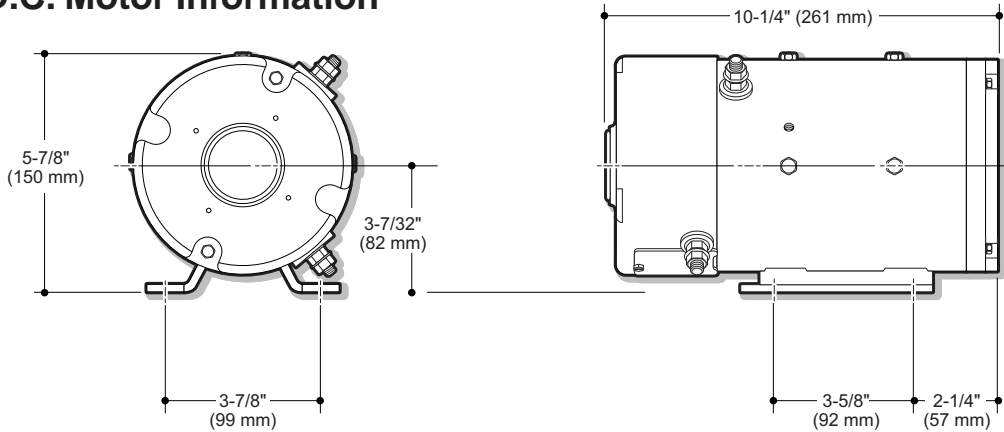

12 Volt D.C. Performance Curves

Voltage = 25.2 - $\sqrt{\frac{\text{AMP} - 40}{10}}$

Test Fluid = Mobil D.T.E. 24
 @ 100°F (SUS 160)
 34°C (CST 34)

Performance Curves for 08066 Motor

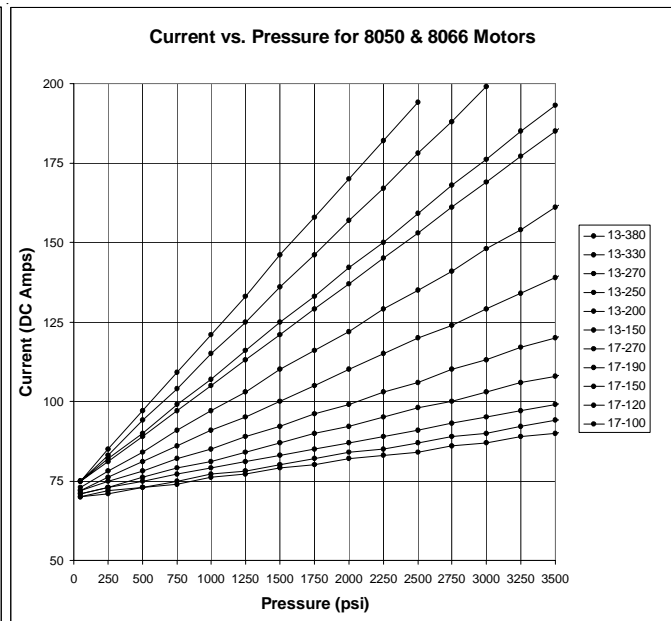
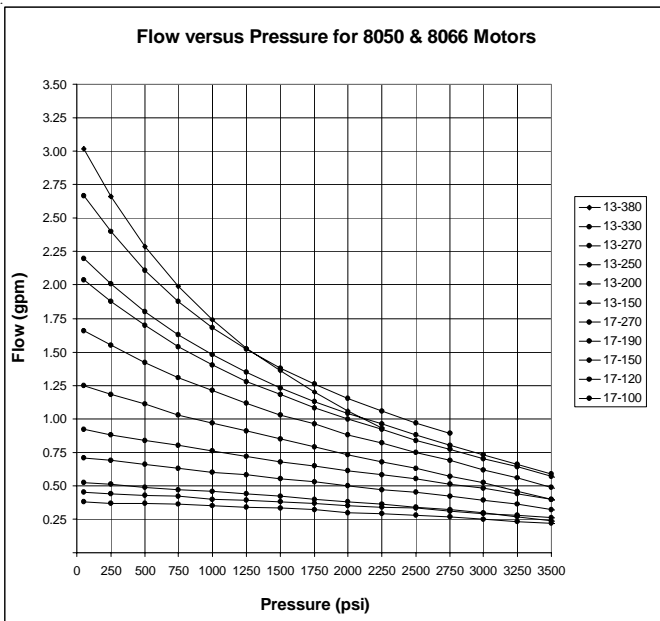

PART NUMBER	VOLTAGE	INSULATION CLASS	NUMBER OF TERMINALS	UL LISTED	DESCRIPTION *SEE KEY
08066	12	H	2	NO	SW/HD

Key to Abbreviations:

PM = Permanent Magnet
 ID = Intermittent Duty

SW = Series Wound
 CW = Compound Wound

HD = Heavy Duty

A Thermal Protection Switch is available as an option on most motors and must be used with a solenoid motor start switch. Refer to the Thermal Chart on Page 86.0 for Motor Thermal Performance Data.

08051 D.C. Motor Information

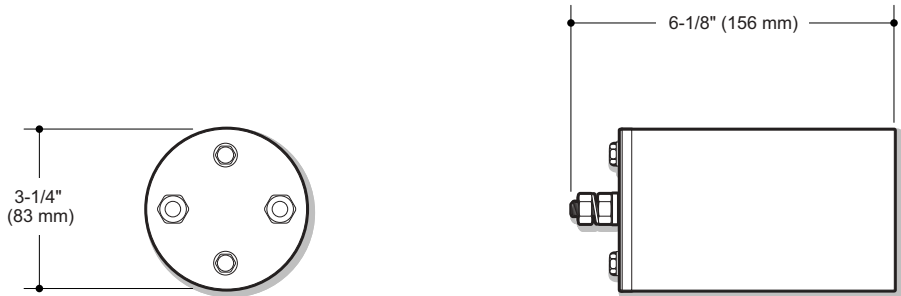

24 Volt D.C. Performance Curves Voltage = $25.2 - \sqrt{\frac{\text{AMP} - 40}{13}}$ Test Fluid = Mobil D.T.E. 24
 @ 100°F (SUS 160)
 34°C (CST 34)

Performance Curves for 08051 Motor

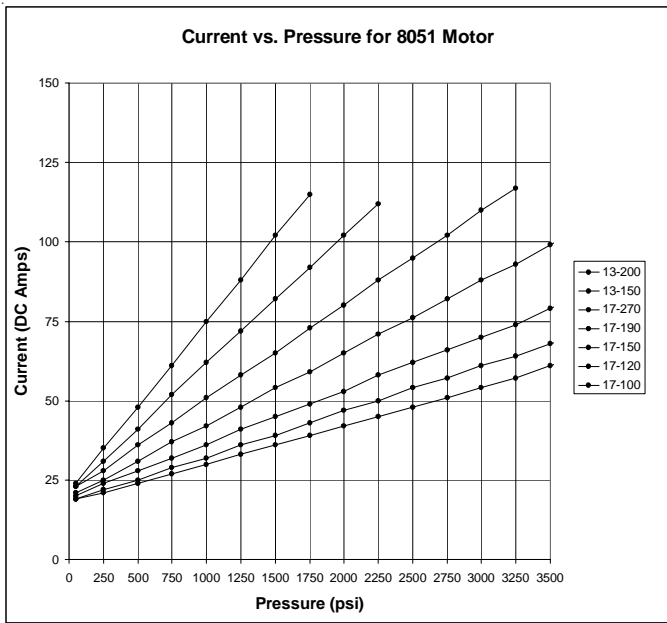
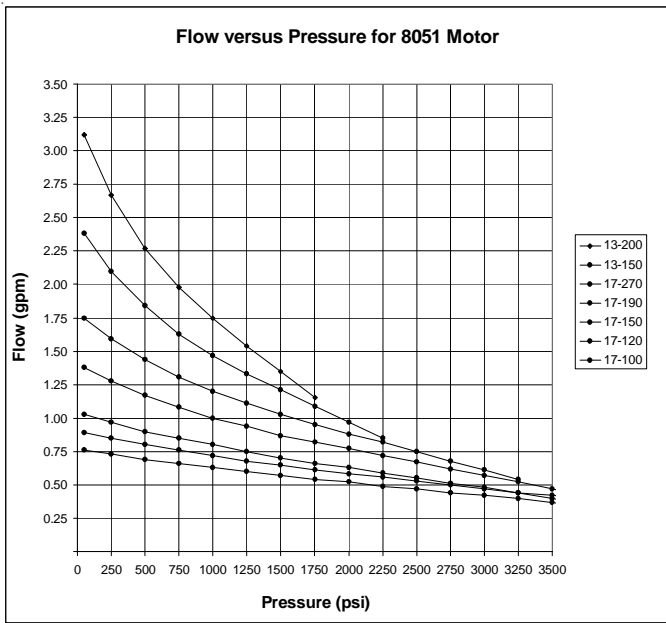

PART NUMBER	VOLTAGE	INSULATION CLASS	NUMBER OF TERMINALS	UL LISTED	DESCRIPTION *SEE KEY
08051	24	A	2	NO	PM/ID

Key to Abbreviations:
 PM = Permanent Magnet SW = Series Wound ED = Extended Duty HD = Heavy Duty
 ID = Intermittent Duty CW = Compound Wound

A Thermal Protection Switch is available as an option on most motors and must be used with a solenoid motor start switch. Refer to the Thermal Chart on Page 86.0 for Motor Thermal Performance Data.



08120 D.C. Motor Information

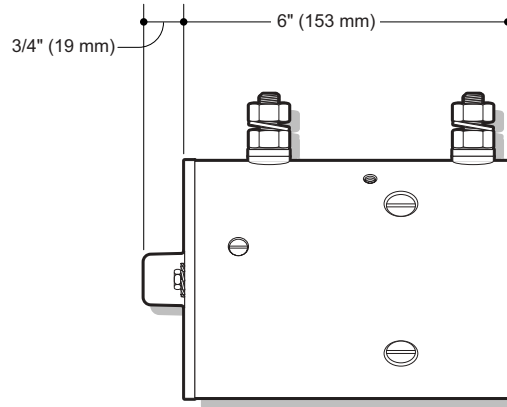
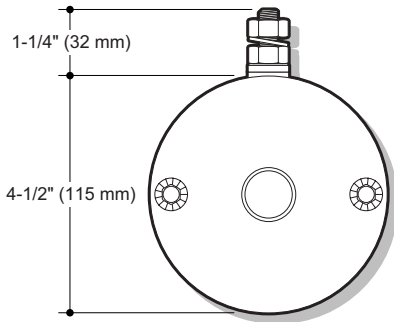

24 Volt D.C. Performance Curves

Voltage = 25.2 - $\sqrt{\frac{\text{AMP} - 40}{10}}$

Test Fluid = Mobil D.T.E. 24
@ 100°F (SUS 160)
34°C (CST 34)

Performance Curves for 08120 Motor

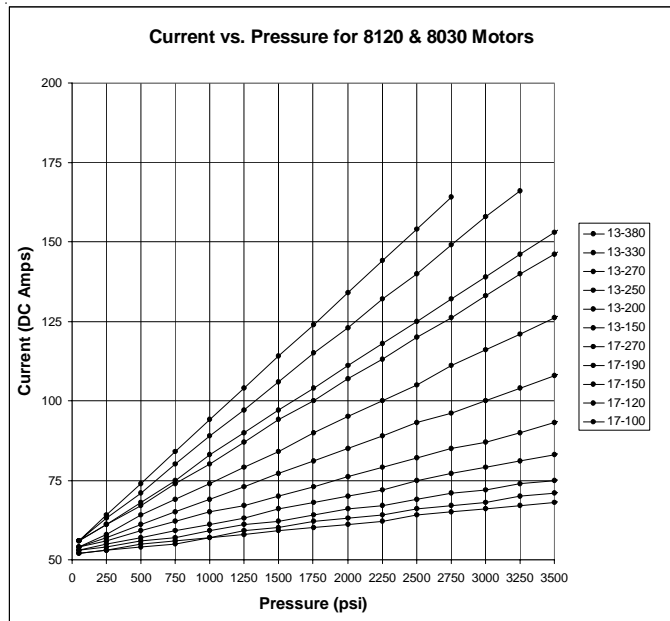
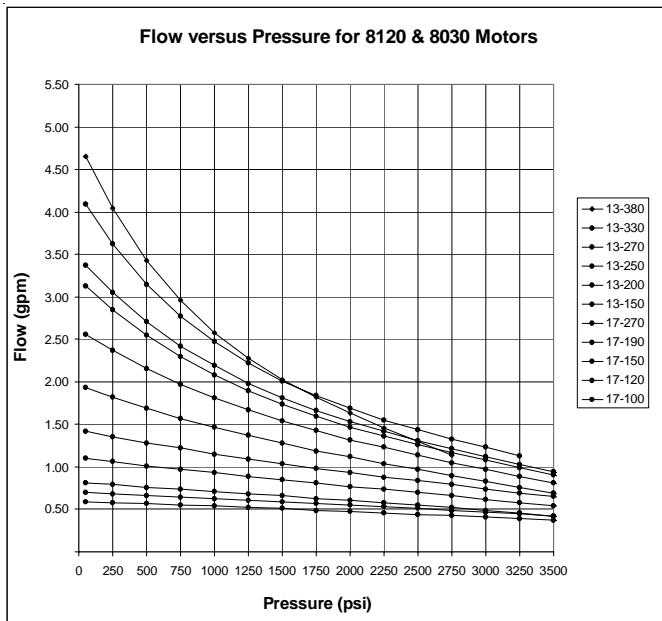

PART NUMBER	VOLTAGE	INSULATION CLASS	NUMBER OF TERMINALS	UL LISTED	DESCRIPTION *SEE KEY
08120	24	B	2	YES	SW/ID

Key to Abbreviations:

PM = Permanent Magnet
ID = Intermittent Duty

SW = Series Wound
CW = Compound Wound

ED = Extended Duty

HD = Heavy Duty

A Thermal Protection Switch is available as an option on most motors and must be used with a solenoid motor start switch. Refer to the Thermal Chart on Page 86.0 for Motor Thermal Performance Data.

08035 D.C. Motor Information

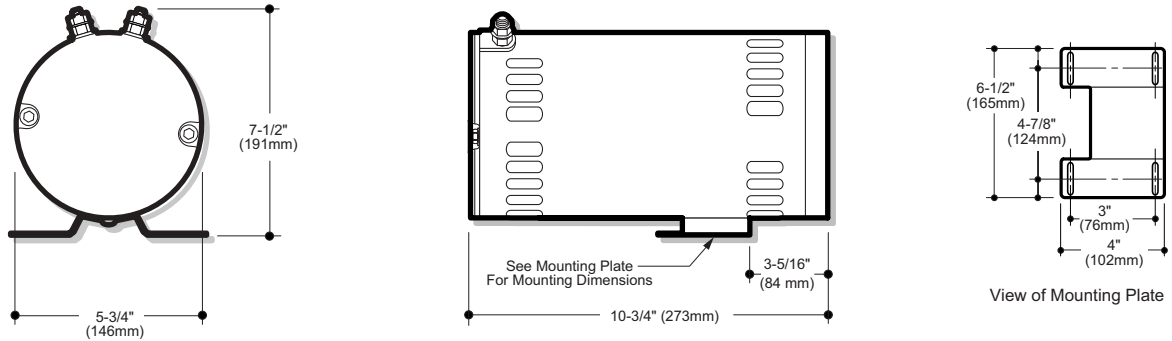

24 Volt D.C. Performance Curves Voltage = $25.2 - \sqrt{\frac{\text{AMP} - 40}{10}}$ Test Fluid = Mobil D.T.E. 24
 @ 100°F (SUS 160)
 34°C (CST 34)

Performance Curves for 08035 Motor

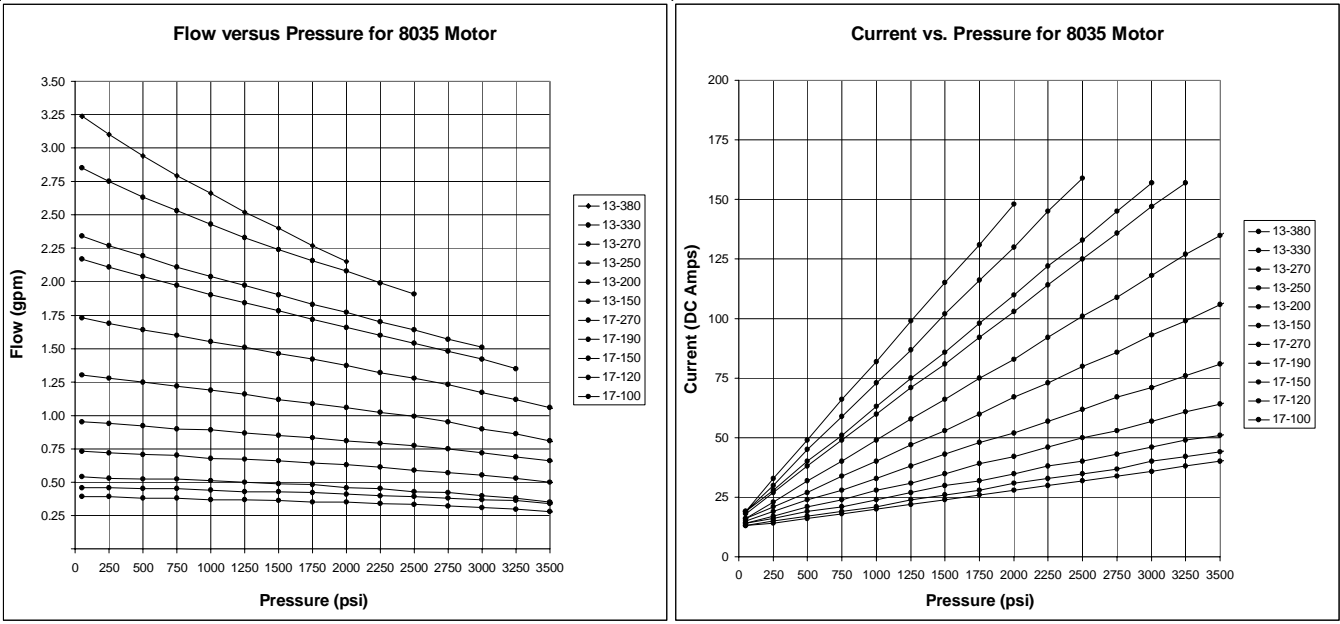

PART NUMBER	VOLTAGE	INSULATION CLASS	NUMBER OF TERMINALS	UL LISTED	DESCRIPTION *SEE KEY
08035	24	H	2	NO	PM/ID

Key to Abbreviations:
 PM = Permanent Magnet SW = Series Wound HD = Heavy Duty
 ID = Intermittent Duty CW = Compound Wound

A Thermal Protection Switch is available as an option on most motors and must be used with a solenoid motor start switch. Refer to the Thermal Chart on Page 86.0 for Motor Thermal Performance Data.



08195 D.C. Motor Information

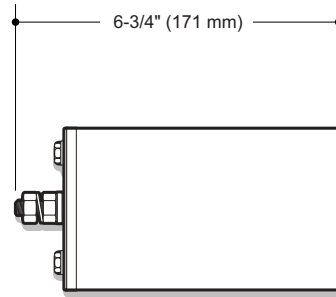
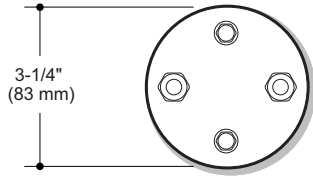

24 Volt D.C. Performance Curves

$$\text{Voltage} = 25.2 - \sqrt{\frac{\text{AMP} - 40}{10}}$$

Test Fluid = Mobil D.T.E. 24
 @ 100°F (SUS 160)
 34°C (CST 34)

Performance Curves for 08195 Motor

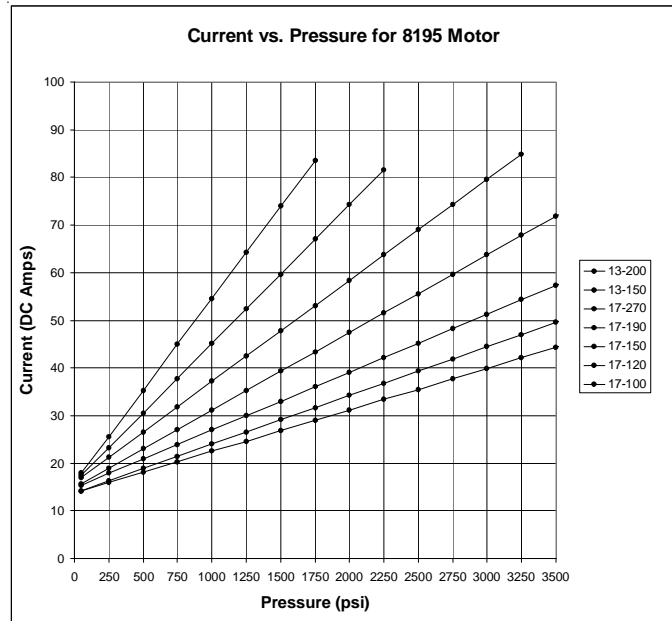
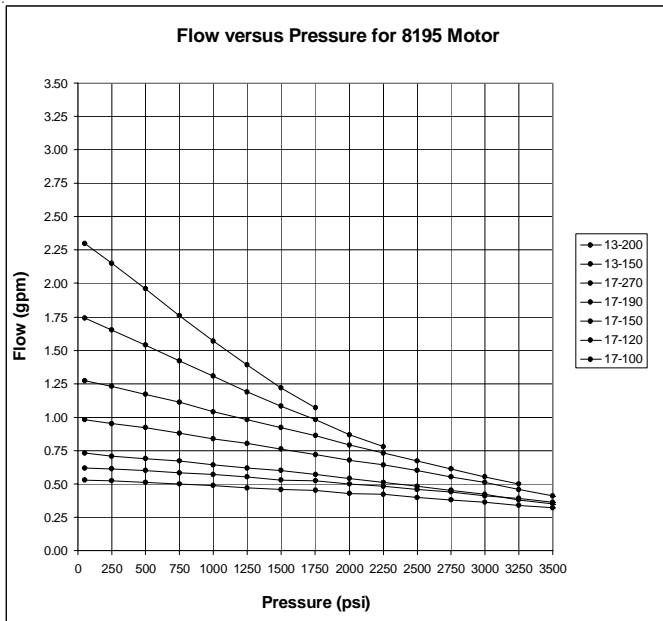

PART NUMBER	VOLTAGE	INSULATION CLASS	NUMBER OF TERMINALS	UL LISTED	DESCRIPTION *SEE KEY
08195	24	F	1	NO	PM/ID

Key to Abbreviations:

PM = Permanent Magnet
 ID = Intermittent Duty

SW = Series Wound
 CW = Compound Wound

ED = Extended Duty

HD = Heavy Duty

A Thermal Protection Switch is available as an option on most motors and must be used with a solenoid motor start switch. Refer to the Thermal Chart on Page 86.0 for Motor Thermal Performance Data.

08168 D.C. Motor Information

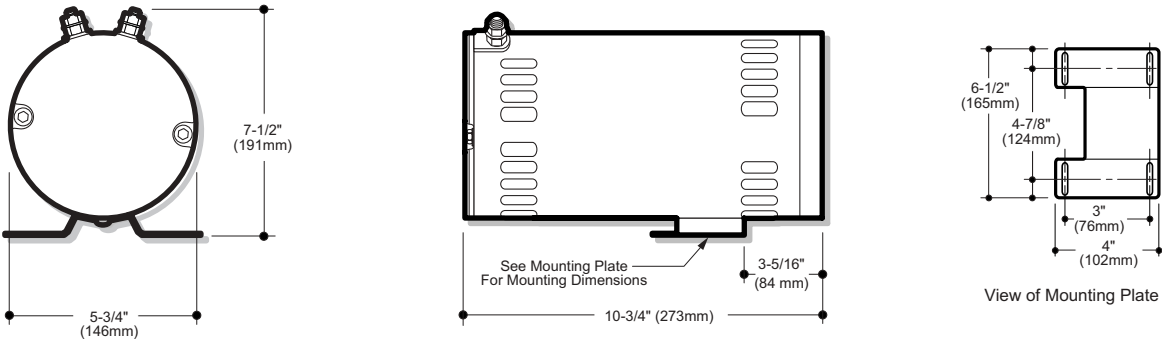

36 Volt D.C. Performance Curves Voltage = 36.5 - .03 x AMPS Test Fluid = Mobil D.T.E. 24
 @ 100°F (SUS 160)
 34°C (CST 34)

Performance Curves for 08168 Motor

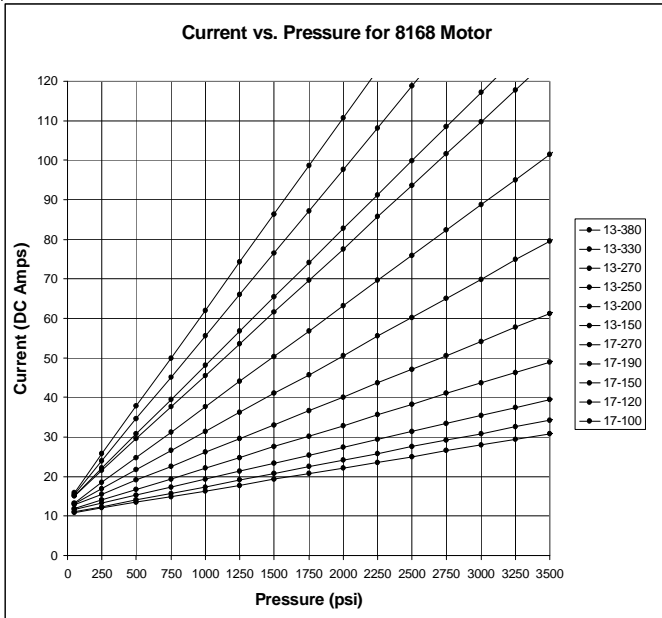
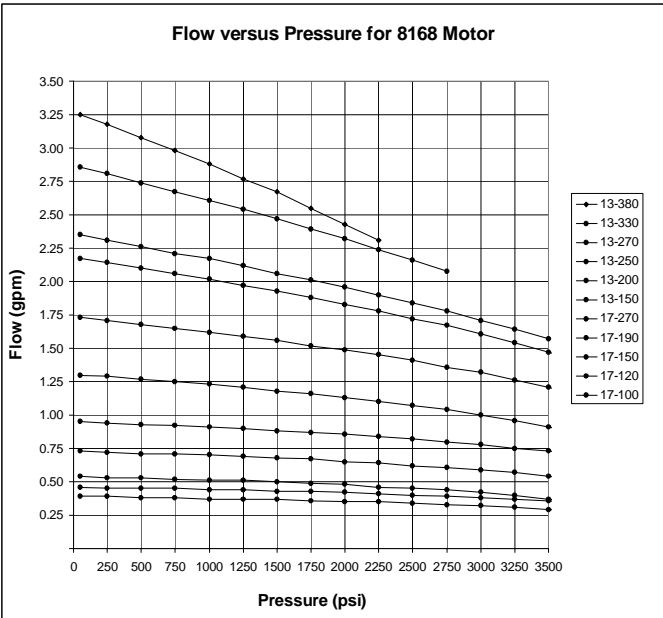

PART NUMBER	VOLTAGE	INSULATION CLASS	NUMBER OF TERMINALS	UL LISTED	DESCRIPTION *SEE KEY
08168	36	H	2	NO	SW/HD

Key to Abbreviations:
 PM = Permanent Magnet SW = Series Wound ED = Extended Duty HD = Heavy Duty
 ID = Intermittent Duty CW = Compound Wound

A Thermal Protection Switch is available as an option on most motors and must be used with a solenoid motor start switch. Refer to the Thermal Chart on Page 86.0 for Motor Thermal Performance Data.



08055 D.C. Motor Information

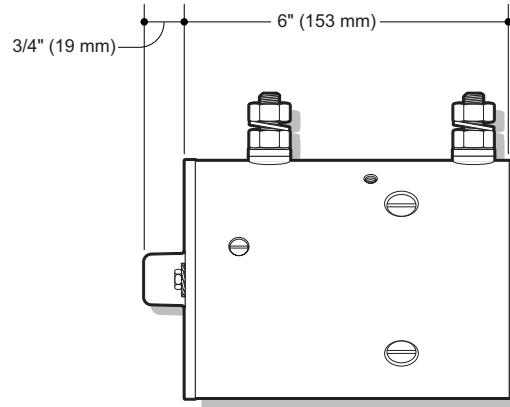
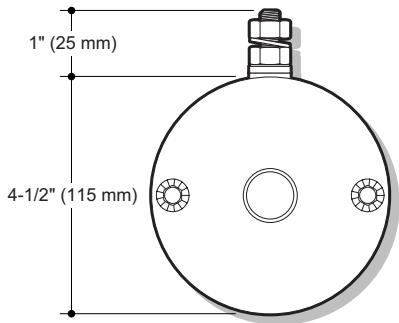

36 Volt D.C. Performance Curves

Voltage = $36.5 - .03 \times \text{AMPS}$

Test Fluid = Mobil D.T.E. 24
 @ 100°F (SUS 160)
 34°C (CST 34)

Performance Curves for 08055 Motor

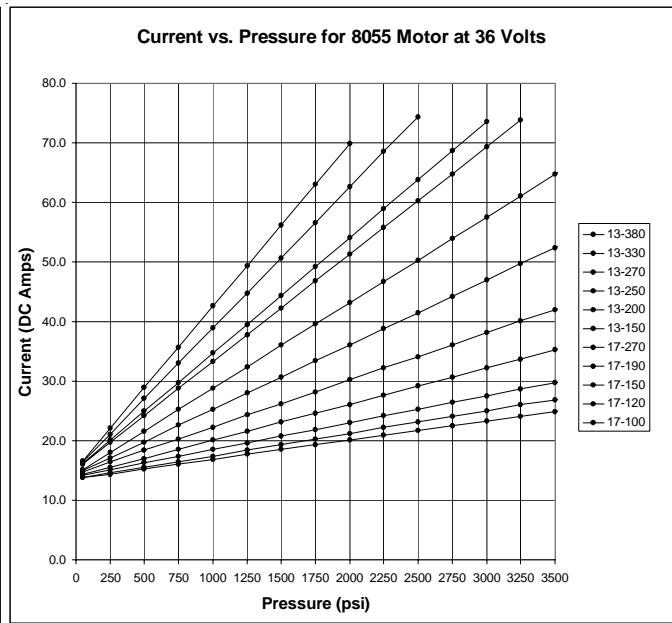
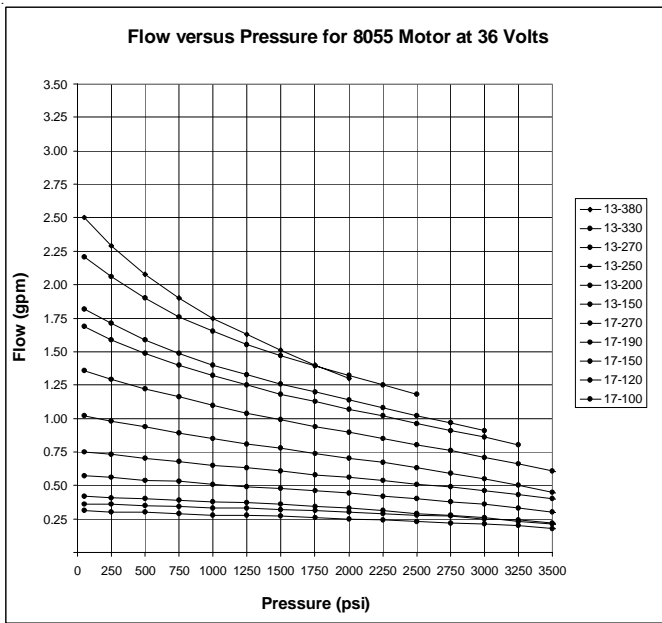

PART NUMBER	VOLTAGE	INSULATION CLASS	NUMBER OF TERMINALS	UL LISTED	DESCRIPTION *SEE KEY
08055	36	B	2	NO	SW/ID

Key to Abbreviations:

PM = Permanent Magnet
 ID = Intermittent Duty

SW = Series Wound
 CW = Compound Wound

ED = Extended Duty

HD = Heavy Duty

A Thermal Protection Switch is available as an option on most motors and must be used with a solenoid motor start switch. Refer to the Thermal Chart on Page 86.0 for Motor Thermal Performance Data.

08040 D.C. Motor Information

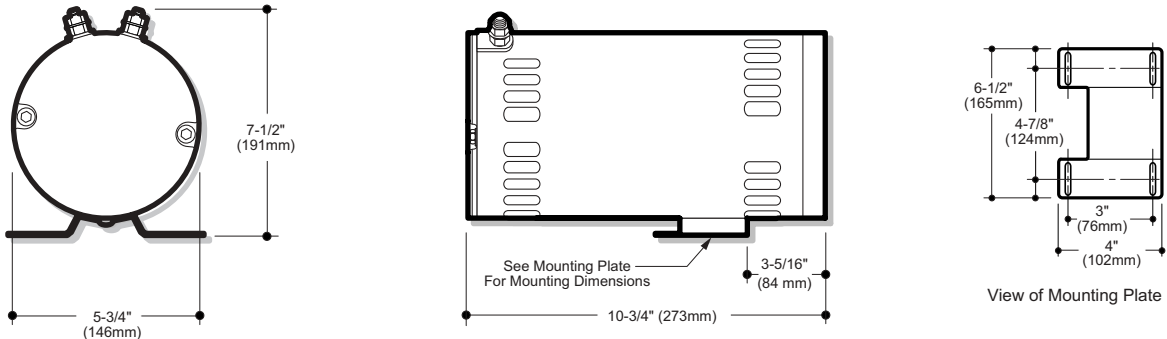

48 Volt D.C. Performance Curves Voltage = 48.5 - .03 x AMPS Test Fluid = Mobil D.T.E. 24
 @ 100°F (SUS 160)
 34°C (CST 34)

Performance Curves for 08040 Motor

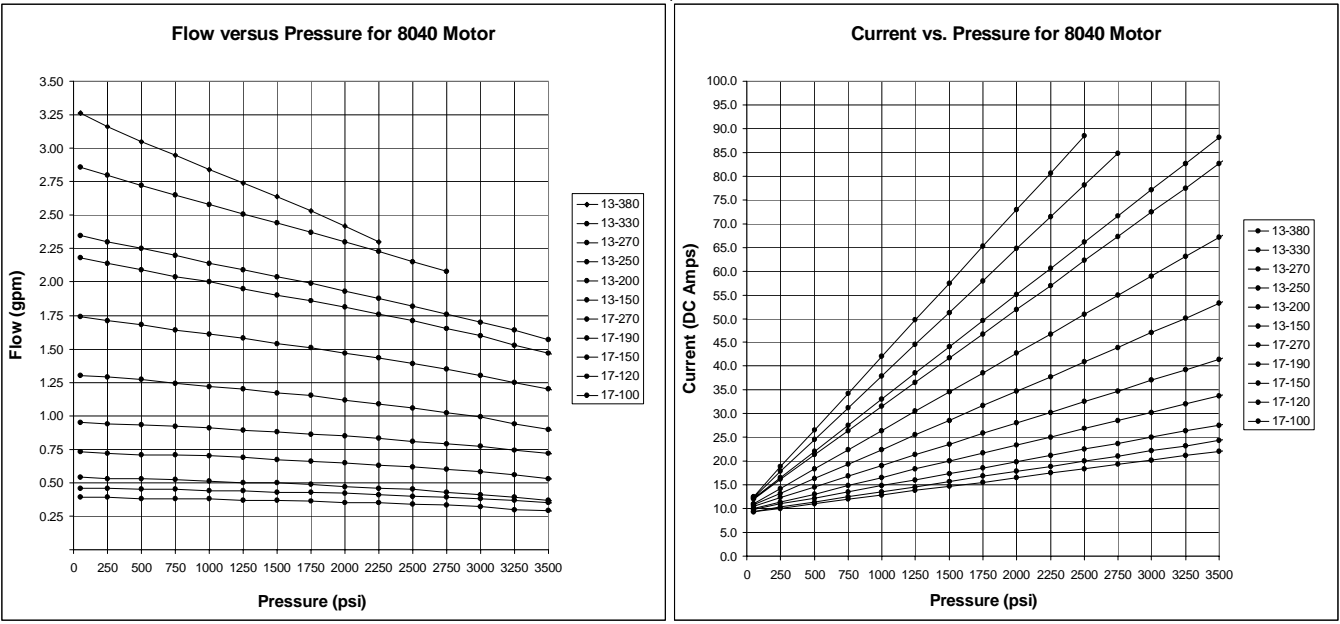

PART NUMBER	VOLTAGE	INSULATION CLASS	NUMBER OF TERMINALS	UL LISTED	DESCRIPTION *SEE KEY
08040	48	H	2	NO	PM/ID

Key to Abbreviations:
 PM = Permanent Magnet SW = Series Wound ED = Extended Duty HD = Heavy Duty
 ID = Intermittent Duty CW = Compound Wound

A Thermal Protection Switch is available as an option on most motors and must be used with a solenoid motor start switch. Refer to the Thermal Chart on Page 86.0 for Motor Thermal Performance Data.



08055 D.C. Motor Information

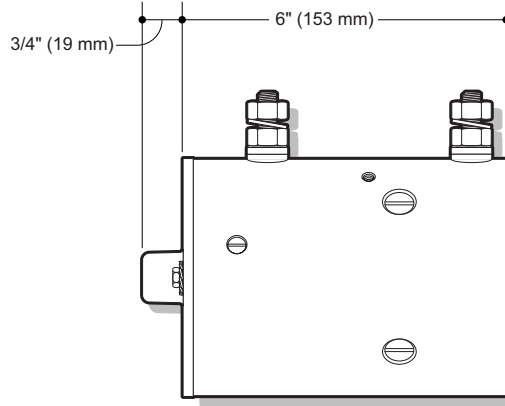
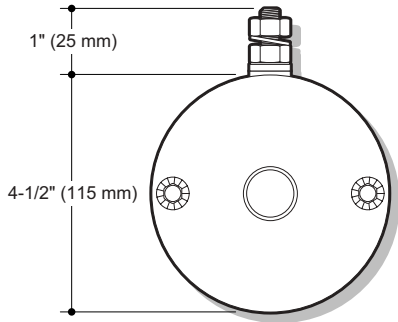

48 Volt D.C. Performance Curves

Voltage = $48.5 - .03 \times \text{AMPS}$

Test Fluid = Mobil D.T.E. 24

@ 100°F (SUS 160)

34°C (CST 34)

Performance Curves for 08055 Motor

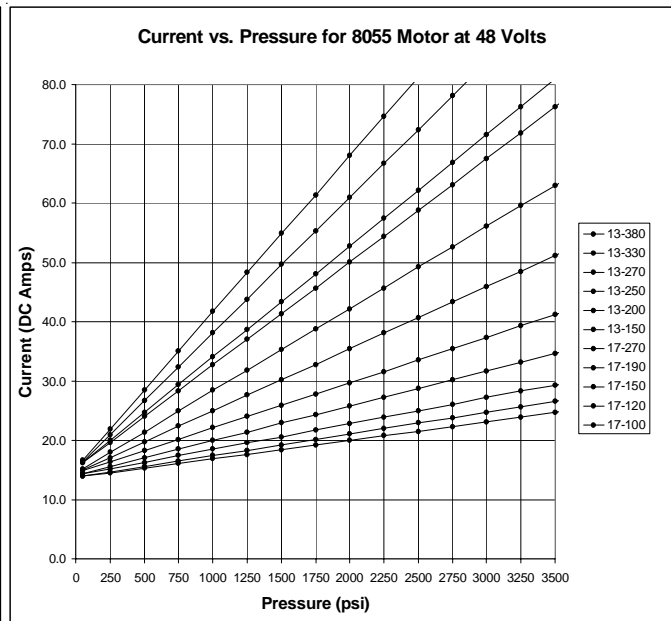
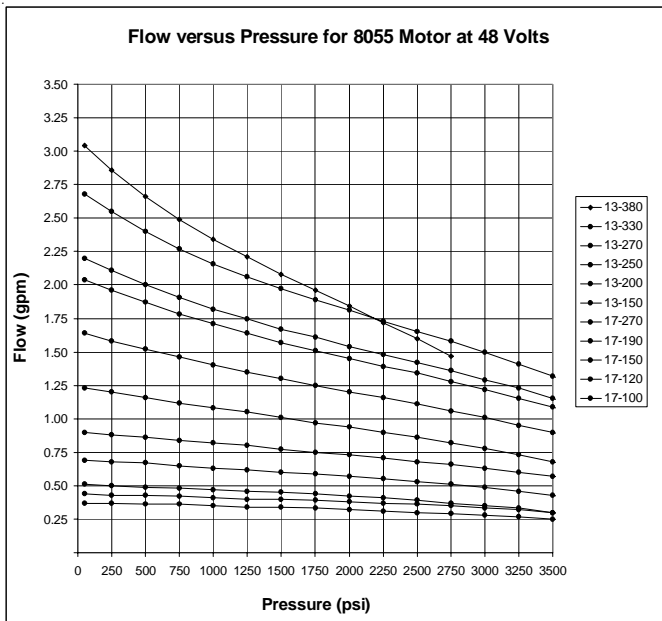

PART NUMBER	VOLTAGE	INSULATION CLASS	NUMBER OF TERMINALS	UL LISTED	DESCRIPTION *SEE KEY
08055	48	B	2	NO	SW/ID

Key to Abbreviations:

PM = Permanent Magnet

SW = Series Wound

ED = Extended Duty

HD = Heavy Duty

ID = Intermittent Duty

CW = Compound Wound

A Thermal Protection Switch is available as an option on most motors and must be used with a solenoid motor start switch. Refer to the Thermal Chart on Page 86.0 for Motor Thermal Performance Data.

08174 D.C. Motor Information

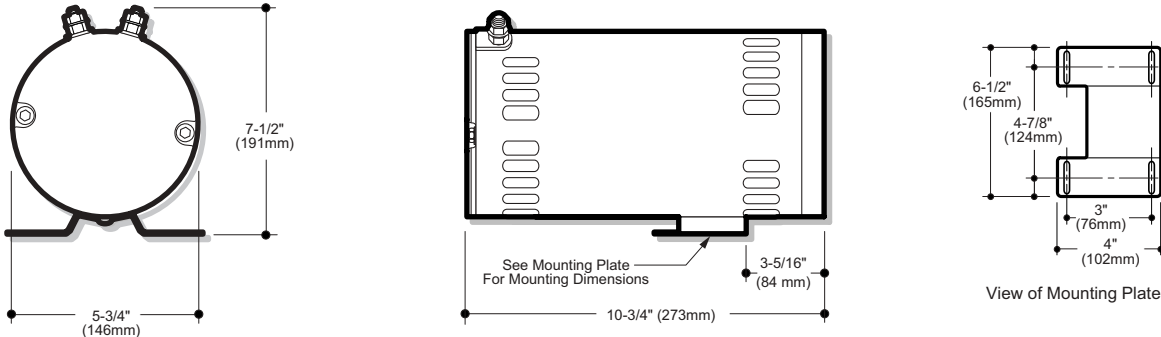

72 Volt D.C. Performance Curves Voltage = 72.4 - .04 x AMPS Test Fluid = Mobil D.T.E. 24
 @ 100°F (SUS 190)
 34°C (CST 34)

Performance Curves for 08174 Motors

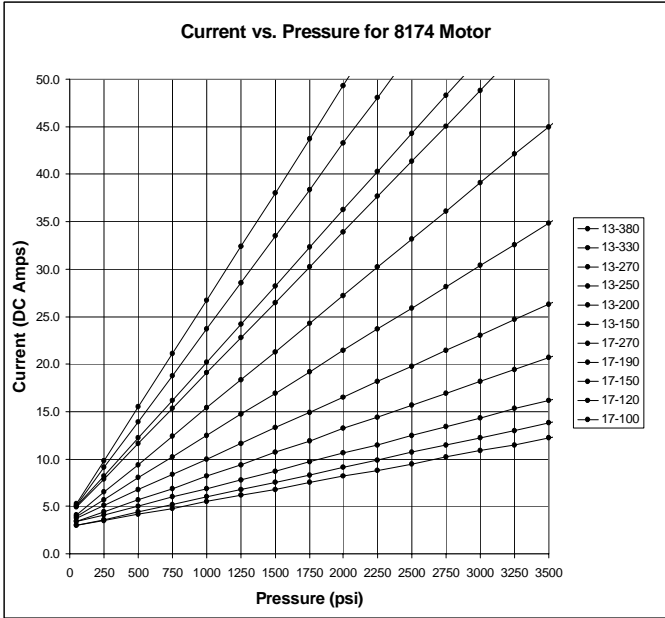
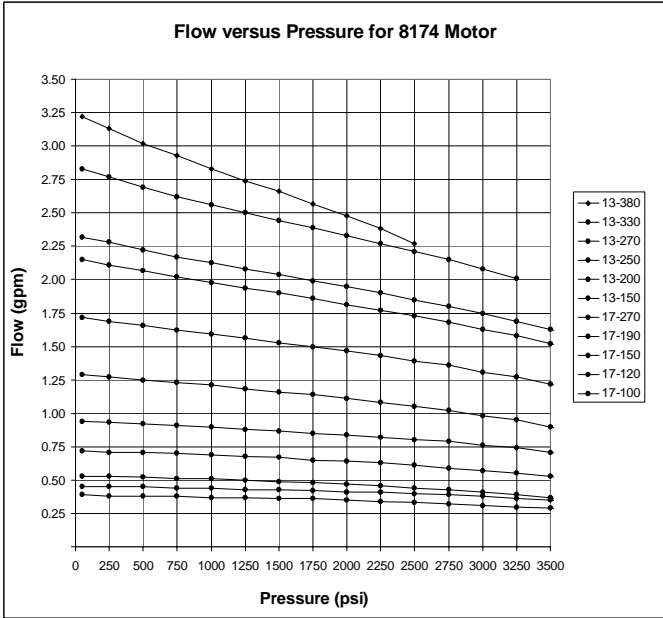

PART NUMBER	VOLTAGE	INSULATION CLASS	NUMBER OF TERMINALS	UL LISTED	DESCRIPTION *SEE KEY
08174	72	H	2	NO	PM/ID

Key to Abbreviations:
 PM = Permanent Magnet SW = Series Wound ED = Extended Duty HD = Heavy Duty
 ID = Intermittent Duty CW = Compound Wound

A Thermal Protection Switch is available as an option on most motors and must be used with a solenoid motor start switch. Refer to the Thermal Chart on Page 86.0 for Motor Thermal Performance Data.



Motor Thermal Performance Data

Monarch offers a comprehensive line of D.C. motors that will operate from light intermittent through extended duty cycles. It is very important to specify the correct motor for your application.

Most D.C. power units operate intermittently and the thermal heat rise is negligible. However, climate, duty cycle, enclosure and the ambient working temperature must all be considered for proper motor selection.

The following charts show the average allowable operating times for our most popular D.C. motors. Initially, it is recommended that you determine the amperage required at the peak working pressure of the pump and motor combination selected and then decide if the motor has the required thermal capacity for your duty cycle. Actual field testing should be performed to confirm that the motor is thermally adequate.

KEY

- A = Amps
- T = Single Maximum run time allowed in minutes. Frequently referred to as S2.
- % = Maximum allowable run time for a repeating 10* minute cycle. Frequently referred to as S3. Note. Some motors are rated for a 5 minute cycle and are so noted on the chart.
- * = No data available.

Example: 08111 Motor. At 100 Amps the motor may be operated continuously for 9.5 minutes after which it must be allowed to completely cool to ambient temperature before the cycle can be repeated. Alternatively, at 100 Amps the motor may be operated for repeating cycles of 150 seconds on and 450 seconds off.

Thermal protection switches are also available on many models that will protect motors from overheating. Contact factory.

08053	12V	A	0	50	100	150	200						
08004		T	*	*	11.0	6.0	3.0	2.0	*	*	*	*	*
		%	*	45%	25%	12%	8%	5%	*	*	*	*	*
08111	12V	A	0	75	100	150	225	300					
08058		T	*	*	9.5	6.0	*	3.0	*	*	*	*	2.0
		%	*	*	25%	20%	*	12%	*	*	*	*	7%
08112	12V	A	0	75	100	150	200	225	300				
08092		T	*	*	12.5	7.5	*	4.0	3.0	*	*	*	1.7
		%	*	*	25%	19%	*	13%	11%	*	*	*	7%
08117	12V	A	0	75	100	150	200	225	300				
08056		T	*	*	17.0	9.0	*	5.0	4.0	*	*	*	2.0
		%	*	*	29%	23%	*	15%	12%	*	*	*	7%
08100	12V	A	0	75	100	150	200	225	300				
		T	*	*	*	15.0	*	10.0	8.0	*	*	*	5.0
		%	*	*	*	30%	*	23%	18%	*	*	*	14%
08050	12V	A	0	75	100	150	200	225	300				
08066		T	*	*	Cont.	Cont.	40.0	20.0	15.0	*	*	*	4.0
	(5 Minute Cycle)	%	*	*	*	*	*	20%	*	*	*	*	*
08163	12V	A	0	75	100	150	200	225	300				
08164		T	*	*	Cont.	Cont.	Cont.	25.0	15.0	*	*	*	1.0
		%	*	*	*	*	*	50%	35%	*	*	*	10%
08051	24V	A	0	25	40	50	60	75	100				
		T	*	*	*	9.0	*	3.0	*	2.0	*	*	*
		%	*	*	*	20%	*	8%	*	5%	*	*	*
08120	24V	A	0	75	100	150	200	225	250	300			
08030		T	*	*	8.0	5.5	3.5	2.0	1.5	1.0	*	*	*
		%	*	*	20%	18%	12%	7%	6%	5%	*	*	*
08035	24V	A	0	75	110	150	200						
08166		T	*	*	Cont.	20	*	10	*	*	*	*	*
08167		%	*	*	Cont.	45%	*	20%	*	*	*	*	5%
08168	36V	A	0	50	80	100	120	150					
08169		T	*	*	CONT.	60.0	10.0	4.0	*	*	*	*	*
08170		%	*	*	100%	55%	23%	10%	*	*	*	*	*
08040	48V	A	0	50	75	100							
08171		T	*	*	CONT.	30.0	*	*	*	*	*	*	8.0
08172		%	*	*	CONT.	40%	*	*	*	*	*	*	15%
08174	72V	A	0	25	40	50	60	75					
08175		T	*	*	CONT.	90.0	20.0	5.0	*	*	*	*	*
08176		%	*	*	CONT.	95%	35%	18%	*	*	*	*	8%

M Series Reservoirs

Steel and Poly



M-Series Reservoirs

Part No.	Length In(mm)	Useable Capacity			
		Horizontal		Vertical	
		In ³	Liter	In ³	Liter
06042	9.00 (229 mm)	190	3.10	168	2.75
06043	10.00 (254 mm)	217	3.56	194	3.20
06044	13.50 (343 mm)	292	4.80	285	4.70
06045	18.00 (458 mm)	394	6.45	405	6.65

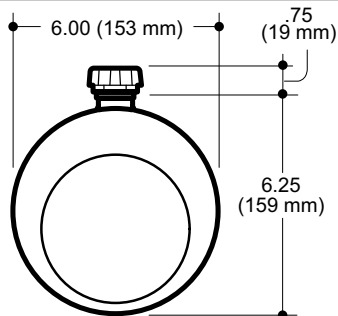

Steel

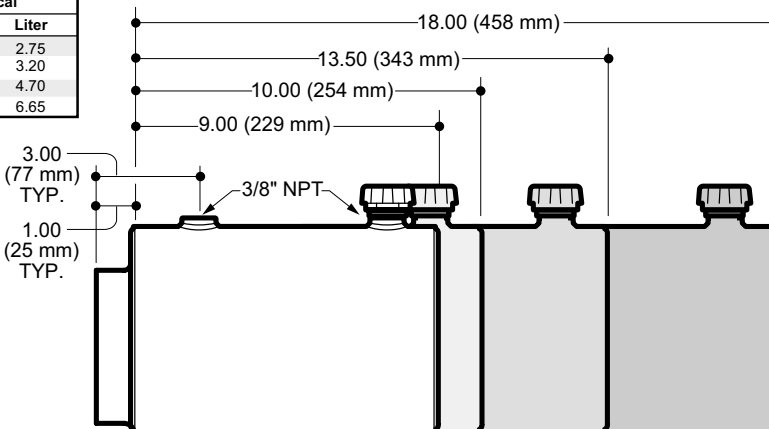

Steel

Part No.	Length In(mm)	Useable Capacity	
		In ³	Liter
06661	8.00 (204 mm)	60	1.00
06663	10.00 (254 mm)	85	1.40
06664	11.00 (280 mm)	98	1.60
06665	12.00 (305 mm)	111	1.80

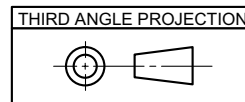
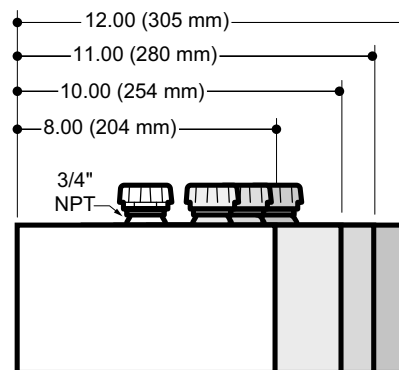
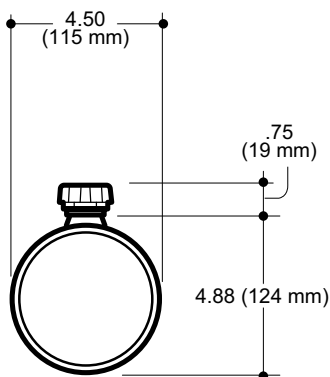

M-Series Reservoirs

Vertical Mounting. Motor Up - Optional.

Part No.	Length In(mm)	Useable Capacity	
		In ³	Liter
06861	7.00 (178 mm)	236	3.86
06862	10.00 (254 mm)	348	5.70
06328	12.00 (305 mm)	406	6.65
06864	15.00 (381 mm)	510	8.36
06888	21.00 (534 mm)	715	11.72

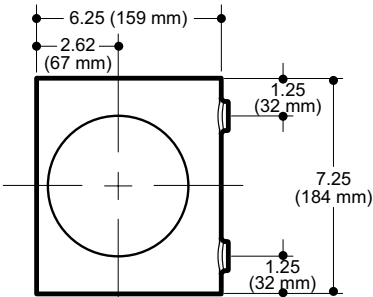

Steel

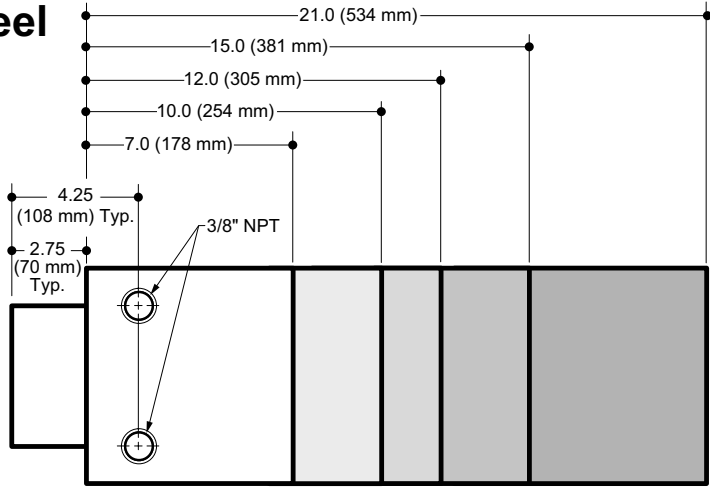

Part No.	Length In(mm)	Useable Capacity	
		In ³	Liter
06982	21.00 (533 mm)	1193	19.55
06397	23.00 (584 mm)	1302	21.33

Steel

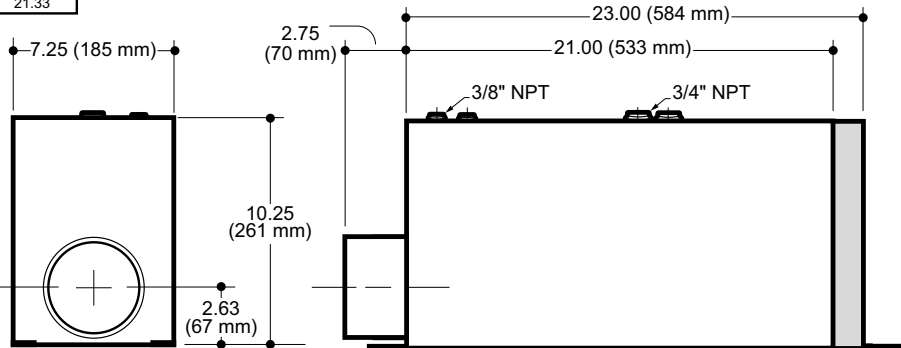

Steel

Useable Capacity		
Part No.	In ³	Liter
06681	1155	18.92

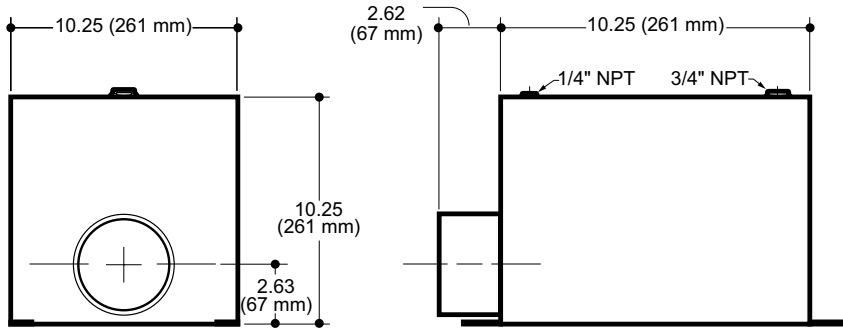

This reservoir is not suitable for modular power units.

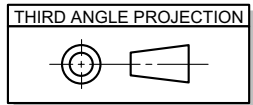

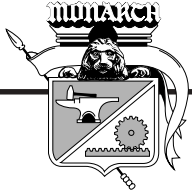

M-Series Reservoirs

Horizontal Mounting			
Part No.	Length In(mm)	Useable Capacity	
		In ³	Liter
06102	8.00 (204 mm)	79	1.3
06103	10.00 (254 mm)	106	1.75
06104	12.00 (305 mm)	134	2.20
06105	13.00 (331 mm)	148	2.40

Vertical Mounting			
Part No.	Length In(mm)	Useable Capacity	
		In ³	Liter
06102	8.00 (204 mm)	55	.90
06103	10.00 (254 mm)	90	1.50
06104	12.00 (305 mm)	125	2.05
06105	13.00 (331 mm)	140	2.30

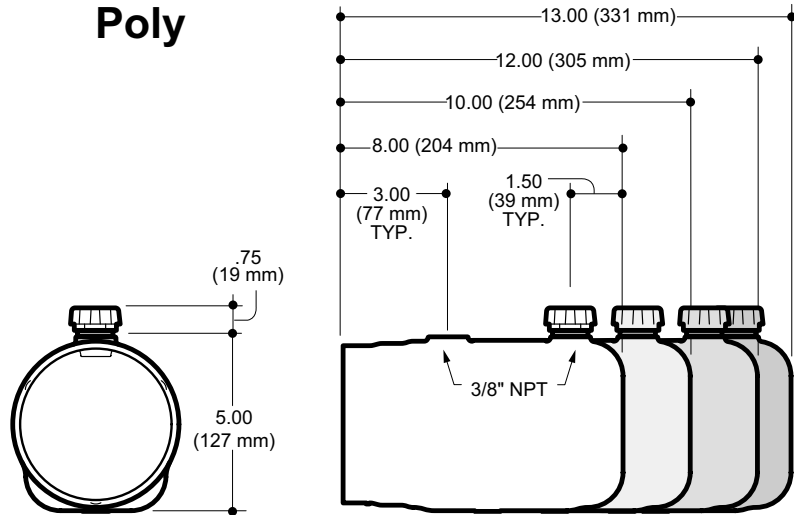

Horizontal Mounting			
Part No.	Length In(mm)	Useable Capacity	
		In ³	Liter
14157	10.00 (254 mm)	199	3.2
14158	13.50 (343 mm)	290	4.7
14159	19.00 (483 mm)	432	7.0

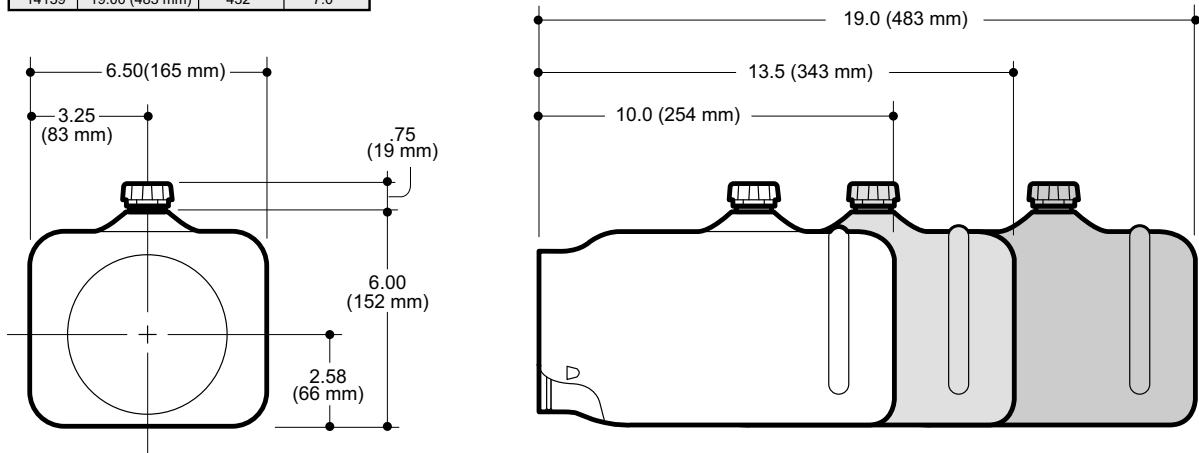

These reservoirs are not suitable for some modular power units. Consult factory for optional reservoirs for your application.

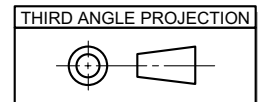

M-Series Reservoirs

Horizontal Mounting			
Part No.	Length In(mm)	Useable Capacity	
		In ³	Liter
14001	9.00 (229 mm)	141	2.3
14002	10.00 (254 mm)	161	2.6
14003	11.00 (279 mm)	183	3.0
14004	13.00 (330 mm)	225	3.6
14005	15.50 (394 mm)	278	4.5
14006	19.00 (483 mm)	352	5.6
14007	22.00 (559 mm)	415	6.7
14008	24.00 (610 mm)	458	7.4

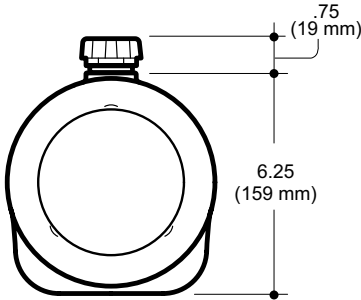

Poly

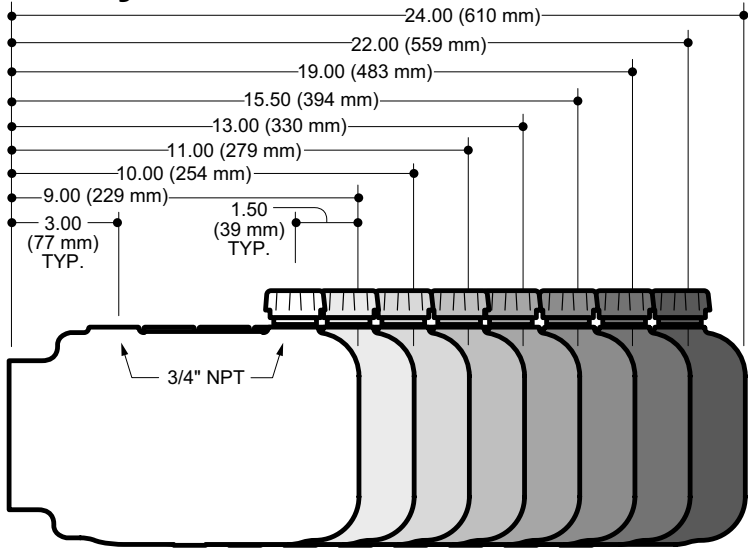

Horizontal Mounting			
Part No.	Length In(mm)	Useable Capacity	
		In ³	Liter
14009	9.00 (229 mm)	160	2.6
14010	10.00 (254 mm)	184	3.0
14011	11.00 (279 mm)	208	3.3
14012	13.00 (330 mm)	256	4.1
14013	15.50 (394 mm)	316	5.1
14014	19.00 (483 mm)	398	6.4
14015	22.00 (559 mm)	471	7.6
14016	24.00 (610 mm)	519	8.4

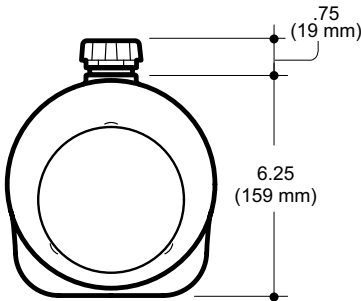

Poly

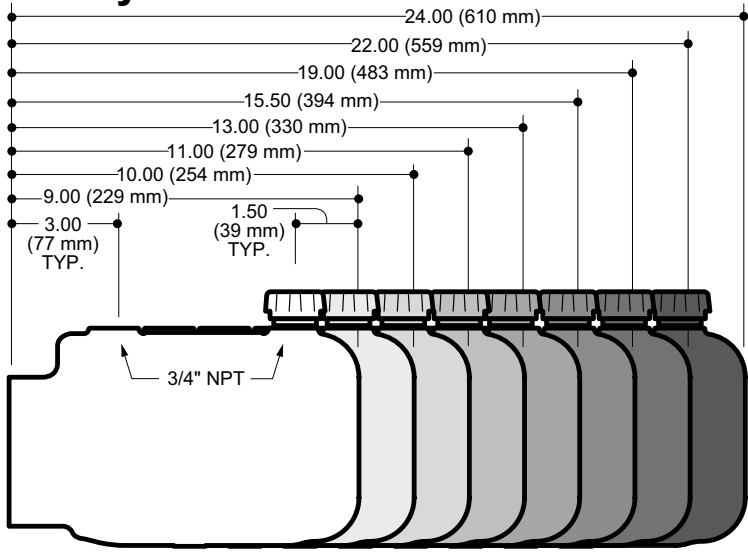

These reservoirs are not suitable for some modular power units. Consult factory for optional reservoirs for your application.

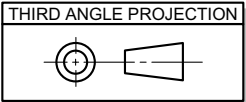

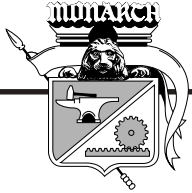

M-Series Reservoirs

Horizontal Mounting			
Part No.	Length In(mm)	Useable Capacity	
		In ³	Liter
14164	7.5 (191 mm)	139	3.1
14165	9.00 (229 mm)	173	3.8
14166	11.00 (279 mm)	217	4.7
14167	13.00 (330 mm)	264	5.6
14168	15.00 (381 mm)	309	6.6
14169	20.00 (508 mm)	423	8.8
14170	26.00 (660 mm)	559	11.7

Vertical Mounting			
Part No.	Length In(mm)	Useable Capacity	
		In ³	Liter
14183	7.5 (191 mm)	85	1.9
14184	9.00 (229 mm)	148	2.9
14185	11.00 (279 mm)	232	4.3
14186	13.00 (330 mm)	316	5.6
14187	15.00 (381 mm)	402	6.9
14188	20.00 (508 mm)	612	10.2
14189	26.00 (660 mm)	872	14.1

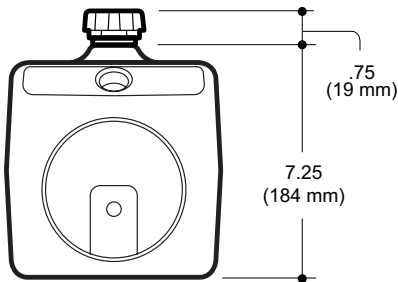

Poly

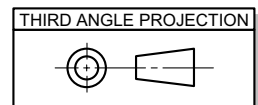
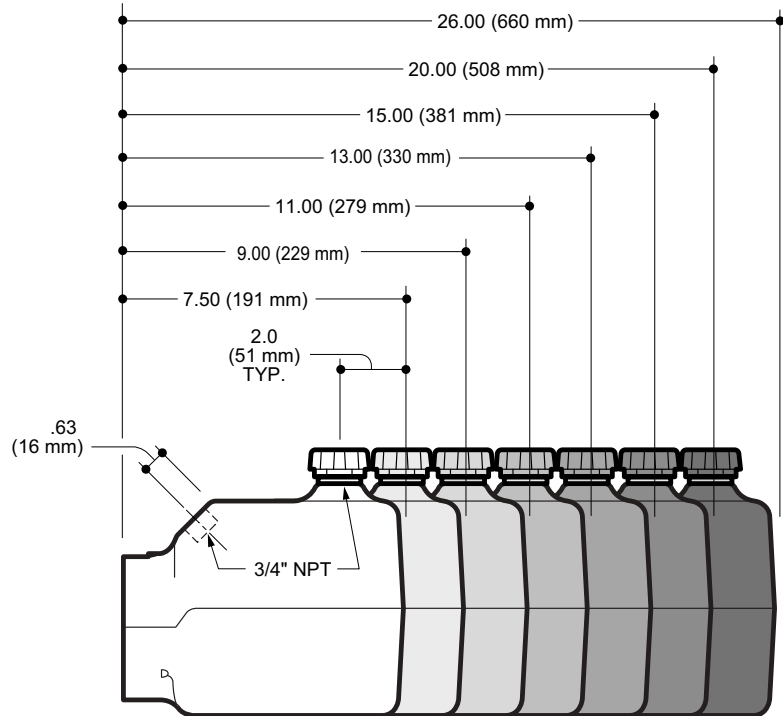

Reservoirs for Mini Units

Part No.	Length	Useable Capacity			
		Horizontal		Vertical	
		In ³	Liter	In ³	Liter
06230	6.46	.31	.50	.27	.45
06231	11.08	.61	1.00	.73	1.21
06233	20.32	1.22	2.00	1.68	2.72

Poly

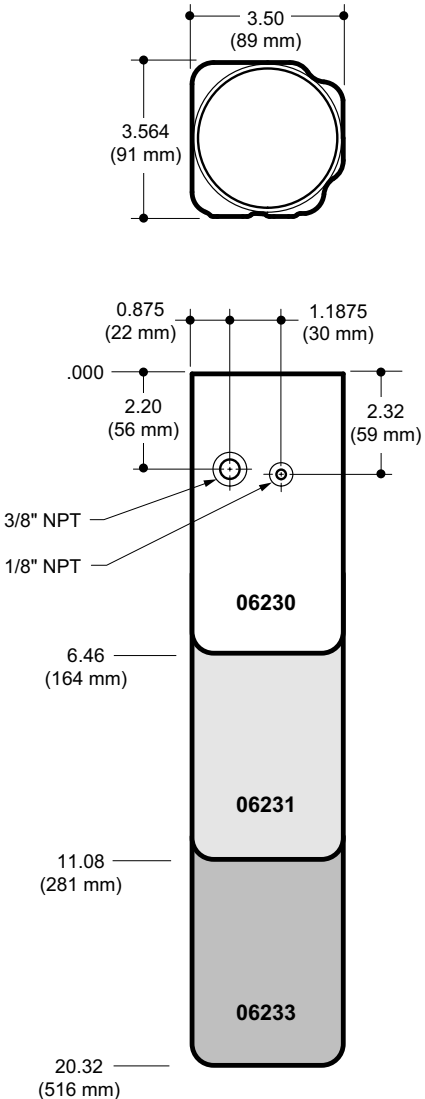

Part No.	Length	Useable Capacity			
		Horizontal		Vertical	
		In ³	Liter	In ³	Liter
06218	4.88	.31	.50	.39	.64
06217	6.76	.61	1.00	.63	1.03
06197	7.75	.77	1.26	.76	1.24
06216	8.64	.92	1.50	.87	1.43
06215	10.52	1.22	2.00	1.11	1.82
06214	12.40	1.52	2.50	1.35	2.21
06213	14.28	1.83	3.00	1.59	2.61

Poly

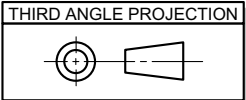
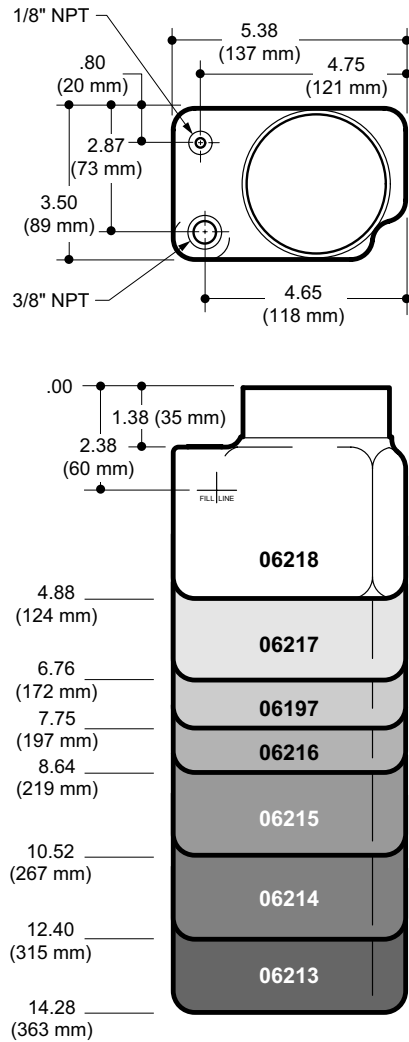



Valves for DC Systems

I. NPFA DO3 Directional and Auxiliary Control Valves.

Solenoid directional and auxiliary controls are typically added to the M-3515 and M-3528. Please refer to the Monarch Directional Control

Valve brochure for additional information and selection.

PART NUMBER	SCHEMATIC	DESCRIPTION
12 VDC - 00962 24 VDC - 00965		4-Way/3-Position. Solenoid Operated. Tandem Center.
12 VDC - 00963 24 VDC - 00966		4-Way/3-Position. Solenoid Operated. Open Center.
12 VDC - 00961 24 VDC - 00964		4-Way/3-Position. Solenoid Operated. Closed Center.
12 VDC - 01040 24 VDC - 01039		4-Way/3-Position, P Blocked. A and B to T. "Motor Spool".
12 VDC - 00460 24 VDC - 00461		4-Way/2-Position. P to A. Spring Offset.
00468		Dual Pilot Operated Check. A and B Port.
00469		Flow Control. Dual Meter Out. A and B Port.
00443		Cross Port Relief. A and B Ports. Adjustable.
00474		Dual Relief. A and B Ports to T. Adjustable.

Consult Monarch about special requirements for explosion proof, shockless (soft shift) and other function and spool configurations not shown here. Other DC as well as AC

voltages are available. Functional symbols related to solenoid identity "A" or "B" according to NFPA/ANSI standards, i.e., energizing solenoid "A" gives flow P to A, solenoid "B" gives flow P to B (As Applicable).

II. Cartridge Valves

Solenoid operated cartridge valves are used in the M-319 and various other models.

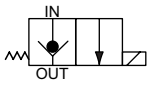
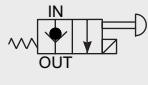
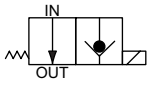
PART NUMBER	SCHEMATIC	DESCRIPTION
12 VDC - 00707 24 VDC - 07158		2-Way/2-Position Normally Closed. Modified Cavity #8. Grounded Coil.
07144		2-Way/2-Position Normally Closed. Modified Cavity #8. Manual Operation. Pull to Open. Spring Closed.
12 VDC - 00501 24 VDC - 00502		2-Way/2-Position Normally Open. Modified Cavity #8. Grounded Coil.

Consult Monarch about many additional valve voltages, coil terminations and other options.

III. Manual Valves

Manually Operated Directional Control Valves are used on Models M-310, M-500 and M-300 Special Units.

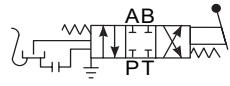
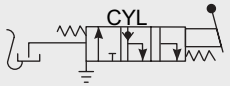
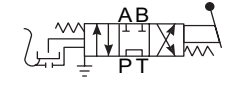
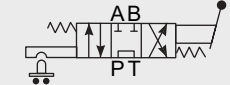
PART NUMBER	SCHEMATIC	DESCRIPTION
M-310 Condenser Type - 01020		4-Way/3-Position. Closed Center. Direct Mounting.
M-500 Type - 00853		3-Way/3-Position. Cylinder Port Checked. Direct Mounting.
M-310 Condenser Type - 00893 M-500 Type - 00856 (Non Condenser Type)		4-Way/3-Position. Tandem Center. Direct Mounting.
M-310 Cam Start SW - 07153		4-Way/3-Position. Tandem Center. Direct Mounting.



Motor Start Switches for D.C. Power Systems

Wiring Diagrams

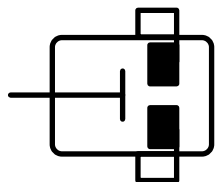

"A"

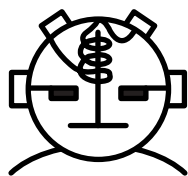

"B"

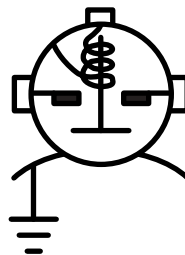

"C"

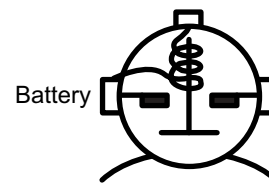

"D"

PART NUMBER	VOLTAGE	WIRING DIAGRAM	COIL DUTY	DESCRIPTION
03336	12	D	Int.	Insulated Ground
17757	12	C	Int.	
03467	24	C	Int.	
17744	12	B	Int.	
03463	24	B	Int.	
17757	12	C	Int.	
17744	12	B	Int.	
07519	24	C	Int.	Tower
17764	24	B	Int.	
03322	12/24	A	N.A.	Manual Start Only - M-301, M-313
04343	12/24	A	N.A.	Round Valve. Cam Start M-310 Only
01349	N.A.	N.A.	N.A.	Bus Bar
13155	N.A.	N.A.	N.A.	Bus Bar for use with 17744 & 17757 Solenoids
04776	N.A.	N.A.	N.A.	Bus Bar for Tower Switches
01361	N.A.	N.A.	N.A.	Battery Cable, 5" Long
01628	N.A.	N.A.	N.A.	Battery Cable, 6" Long

Switches are available with curved mounting for direct attachment to power unit or with flat base for remote mounting. Other Motor Start Switches are also available. Contact Factory.

Key To Abbreviations. H.D. = Heavy Duty
Int. = Intermittent Duty

Control Stations

FIGURE 1

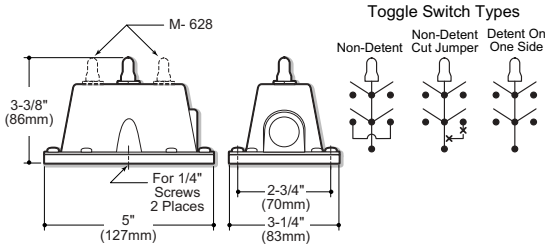

FIGURE 3

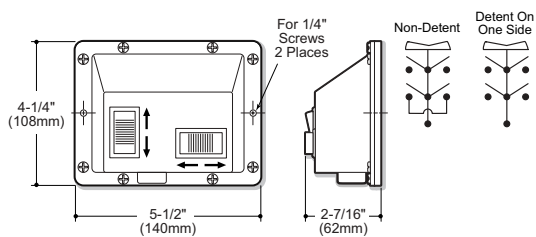

FIGURE 2

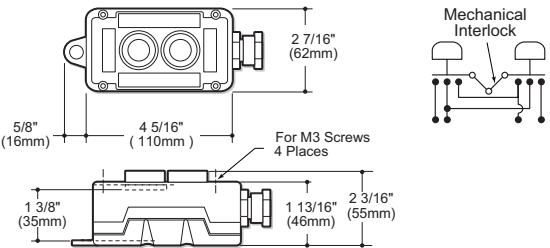

FIGURE 4

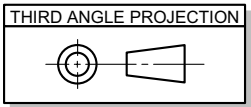
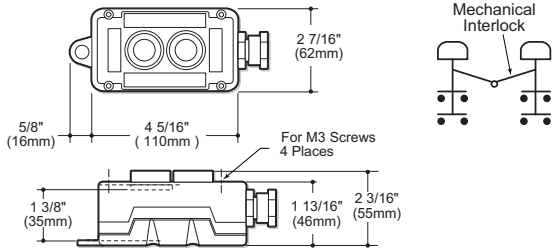
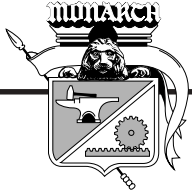
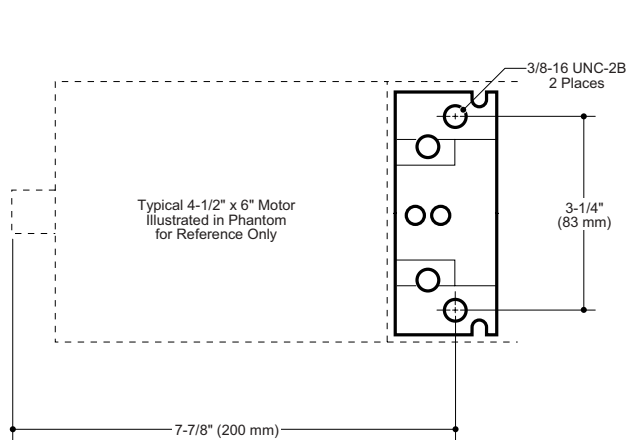

FIGURE	SWITCH SYMBOL	MODELS USED ON	PART NUMBER
1*		M-303, M-319, M-314, M-3519, M-3541	03409
1*		M-642, M-3551, M-3515, M-3554	03487
1		M-3528 M-303, M-319, M-314, M-3519, M-719	03451
2		M-642, M-3551, M-3515, M-3530, M-3547, M-3554	07995
3		M-680'S	03197 (DETENTED) 03201 (NON-DETENTED)
4		M-303, M-319, M-314, M-3519, M-719	07993

NOTE: The above Control Stations may be used with other Power Units. Consult Factory.



Mounting Brackets



04560

May Be Used on Most M Series Units with 4.5" \varnothing (114mm \varnothing) Base, M 10 x 1.5 Thread also Available. Consult Factory.

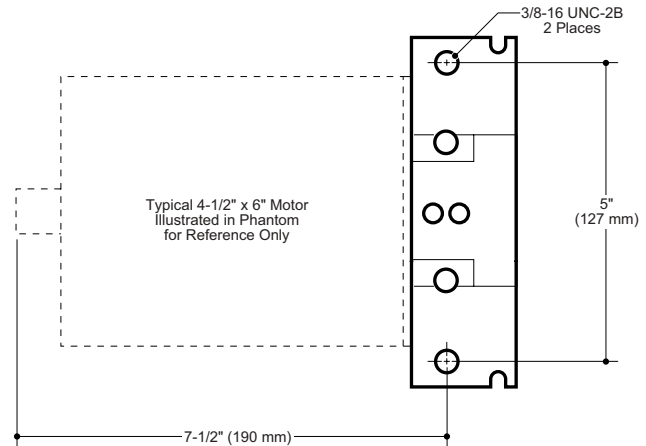

04559

May Be Used on Most M Series Units with 4.5" \varnothing (114mm \varnothing) Base, M 10 x 1.5 Thread also Available. Consult Factory.

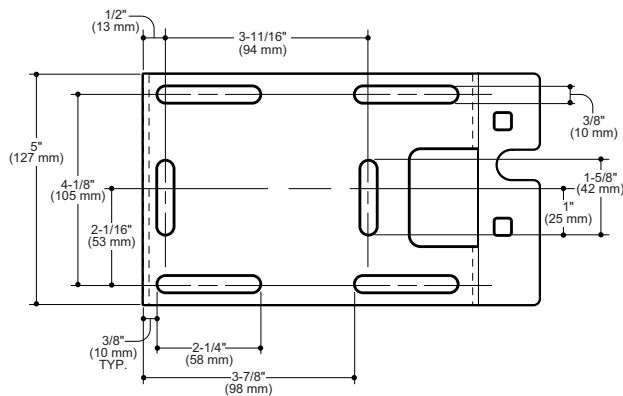

02238

May Be Used With Motors: 08055, 08056, 08057, 08092, 08111, 08112, 08117, 08120

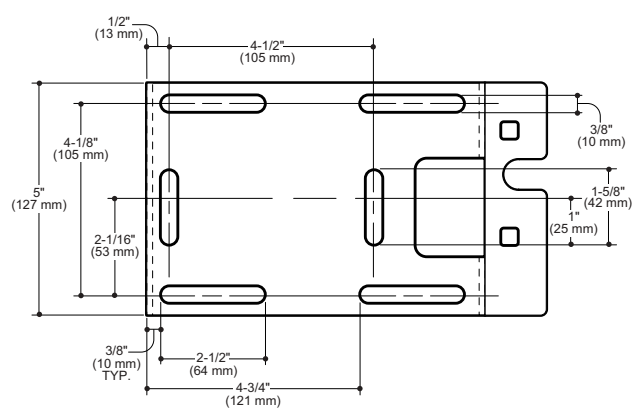

01289

May Be Used With Motor: 08100

Motors 08035, 08040, 08050, 08163, 08168, and 08174 have their own mounting bracket (see motor dimension section of this catalog). Custom brackets are also available. Contact factory.

Popular Accessories For DC Power Systems

PART NUMBER	DESCRIPTION
01436	Sight Level/Temperature Gauge. For Use on Large Reservoirs Only.
01516	Reservoir Breather, Flush Mount, .375" NPT. Cross Scored
03171	Reservoir Breather, .375" NPT.
01143	Reservoir Breather, .750" NPT.
01670	Sight Glass. 3/4" NPT.
03219	Pressure Gauge. Liquid Filled. 1/4" NPT. 0-500 PSI.
01434	Pressure Gauge. Liquid Filled. 1/4" NPT. 0-3000 PSI.
01790	Pressure Gauge. Liquid Filled. 1/4" NPT. 0-5000 PSI
00570	Gauge Shutoff. 1/4" NPT.
00904	Flow Control, Adjustable. Non Pressure Compensated. 1/4" NPT. F x F For Flows to 3.0 GPM (11.4 LPM)
00620-X.XX	Flow Control, Pressure Compensated. Fixed. 1/4" NPT F x F. Other Types Available. Specify Flow Required.
01875	Filter, Return Line. 15 GPM. 10 Micron Nominal.
04369	Filter, Return Line. 5 GPM. 10 Micron Nominal.
01425	Filter/Breather, Chrome Plated. Basket Strainer.
04202	M-310 Cam Start Switch Conversion Kit.
07157	Relief Valve, Cartridge. 1500-3000 PSI. Other Pressure Ranges Also Available.
00081	By-Pass Relief Valve. Inline. Adjustable.
01506	Terminal Cover, Rubber. #4 Cable
03981	Hand Pump, Standard
03987	Hand Pump, Mini Direct, Right Hand. High Pressure - Low Displacement
03943	Hand Pump, Mini Direct, Left Hand. High Pressure - Low Displacement
07435	Hand Pump, High Pressure - Heavy Duty
03695	Valve Cover Cap Kit, M-693.

Other Available Options and Accessories Include:

- Float Switches
- Special Manifold Circuits
- Pressure Switches
- Multi-Function Valve Controls - Monoblock and Sectional
- Special Cartridge, Industrial and Manual Valve Configurations.

NOTE: Accessories Will Not Fit Every Model. Please Contact the Factory For Assistance.

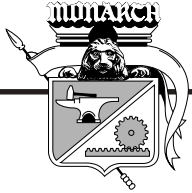

MONARCH HAND PUMPS

Standard - Standard Displacement (0.50 In³/Stroke)
 High Pressure - Low Displacement (0.25 In³/Stroke)
 High Pressure/Heavy Duty - Standard Displacement (0.50 In³/Stroke)

Note

It is recommended that pins and piston be periodically lubricated to prolong hand pump life.

STANDARD HAND PUMPS

Description:

- 0.50 In³/Stroke (8.20 Cm³/Stroke)
- Single Acting
- 2000 PSI (138 Bar)
- Outlet Port: 1/4" NPTF
- Ideal For Emergency Back-Up Application in Case of Primary Pump Failure
- Horizontal or Vertical Mounting
- Designed for Mounting Directly to Monarch Power Units
- Handle May Positioned in any Direction
- Release Valve (Use Handle for Actuating)
- Supplied with Painted Steel "Comfort Grip" Handle
- All Exposed Materials are Aluminum or Plated Steel for Corrosion Resistance

Options:

- Remote Mounting
- Ports. Other Styles Available
- Relief Valve
- Integral Reservoir

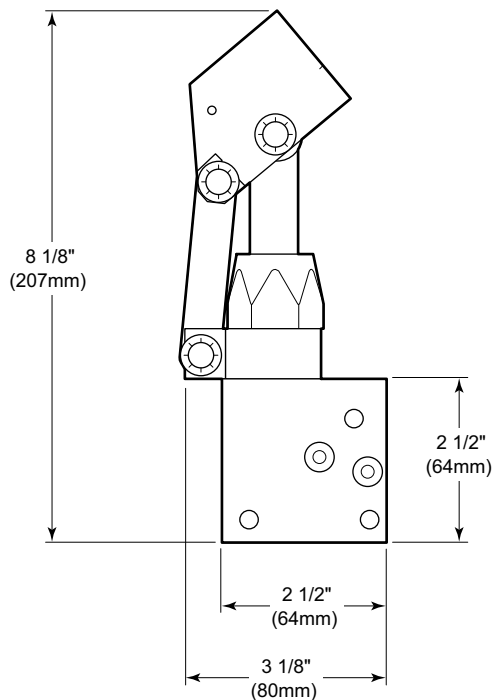
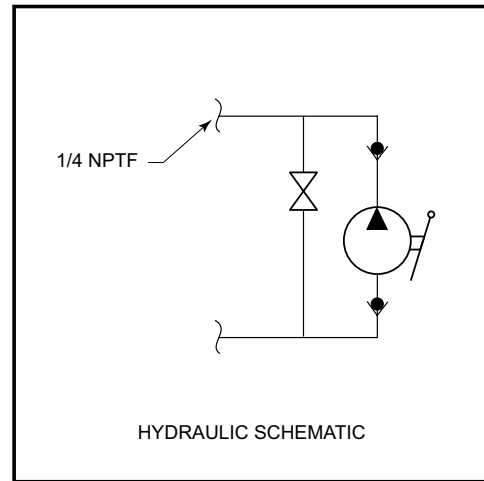

SIDE VIEW

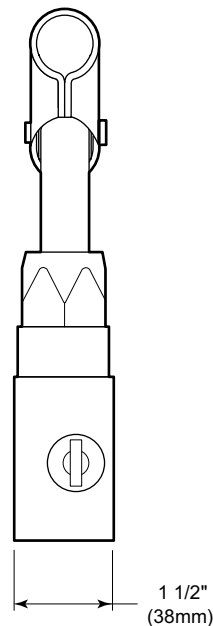

END VIEW

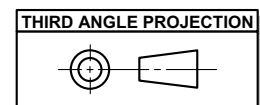

HIGH PRESSURE - LOW DISPLACEMENT HAND PUMP

Description:

- 0.25 In³/Stroke (4.10 Cm³/Stroke)
- Single Acting
- 3500 PSI (240 Bar)
- Outlet Port: 1/4" NPTF
- Ideal For Emergency Back-Up Application in Case of Primary Pump Failure
- Horizontal or Vertical Mounting
- Designed for Mounting Directly to Monarch Power Units
- Handle May Positioned in any Direction
- Release Valve (Use Handle for Actuating)
- Supplied with Painted Steel "Comfort Grip" Handle
- All Exposed Materials are Aluminum or Plated Steel for Corrosion Resistance

Options:

- Remote Mounting
- Ports. Other Styles Available
- Relief Valve

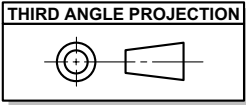
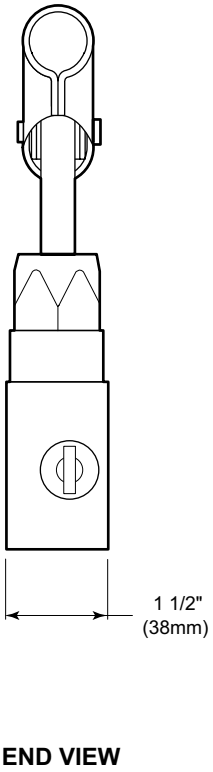
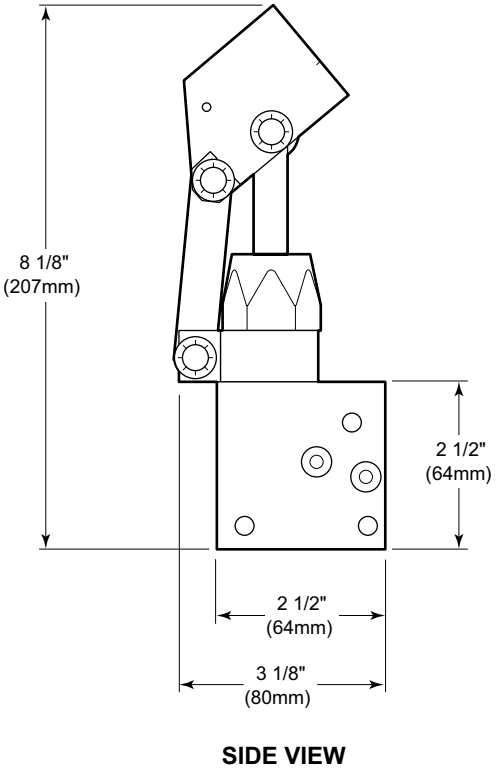
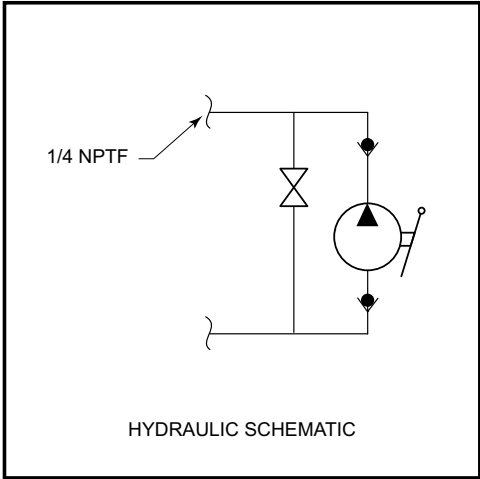

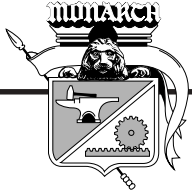

HIGH PRESSURE - HEAVY DUTY HAND PUMP

Description:

- 0.50 In³/Stroke (8.20 Cm³/Stroke)
- Single Acting
- 4000 PSI (275 Bar)
- Outlet Port: 1/4" NPTF
- Heavy Duty Plated Steel Tension Link and Extruded Aluminum Top and Bottom Brackets
- Ideal For Emergency Back-Up Application in Case of Primary Pump Failure
- Horizontal or Vertical Mounting
- Designed for Mounting Directly to Monarch Power Units
- Handle May Positioned in any Direction
- Release Valve (Use Handle for Actuating)
- Supplied with Painted Steel "Comfort Grip" Handle
- All Exposed Materials are Aluminum or Plated Steel for Corrosion Resistance

Options:

- Remote Mounting
- 1/4" NPTF Ports. Other Styles Available
- Relief Valve

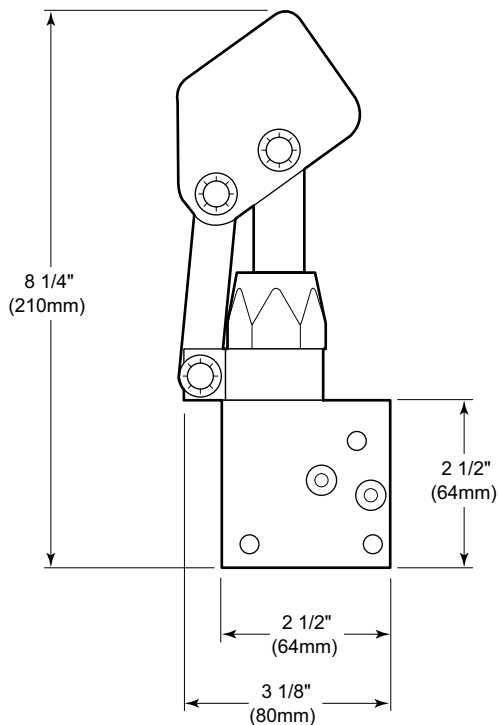
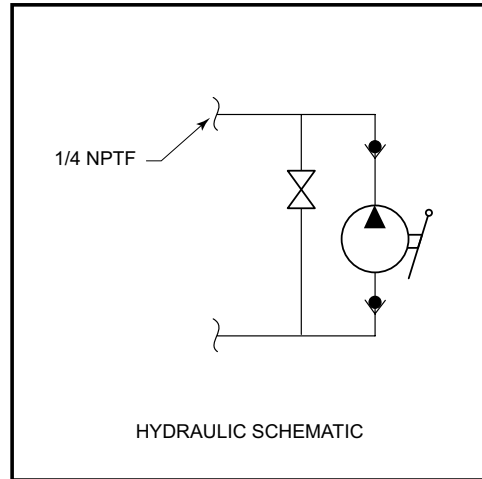

SIDE VIEW

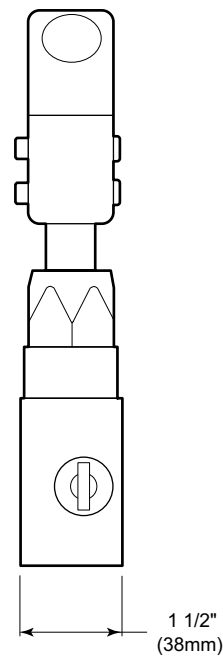

END VIEW

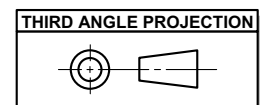

HEAVY DUTY REMOTE HAND PUMP

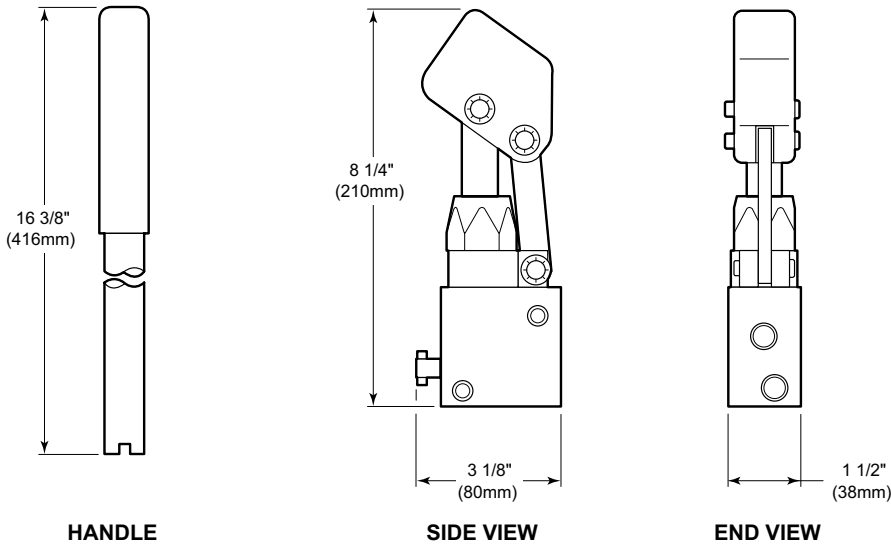

MODEL H-100 SERIES HAND PUMPS WITH RESERVOIRS
Hand Pump with Relief Valve and Reservoir

- 12139 Standard Duty Hand Pump with Relief Valve
- 12140 Heavy Duty Hand Pump with Relief Valve

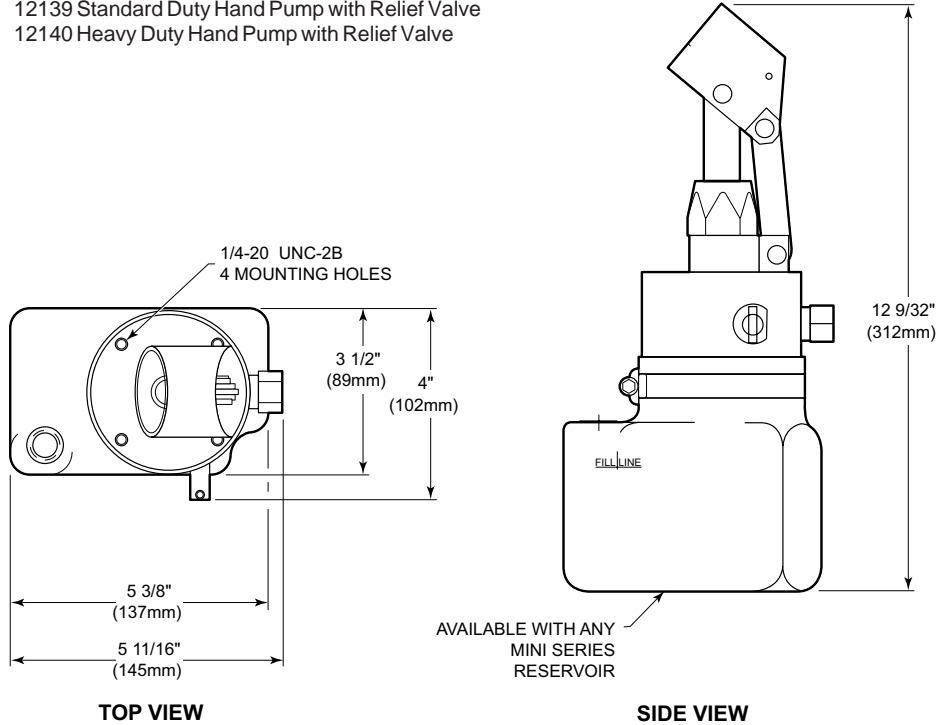

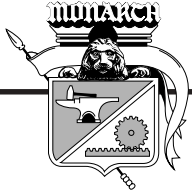

Battery Cables

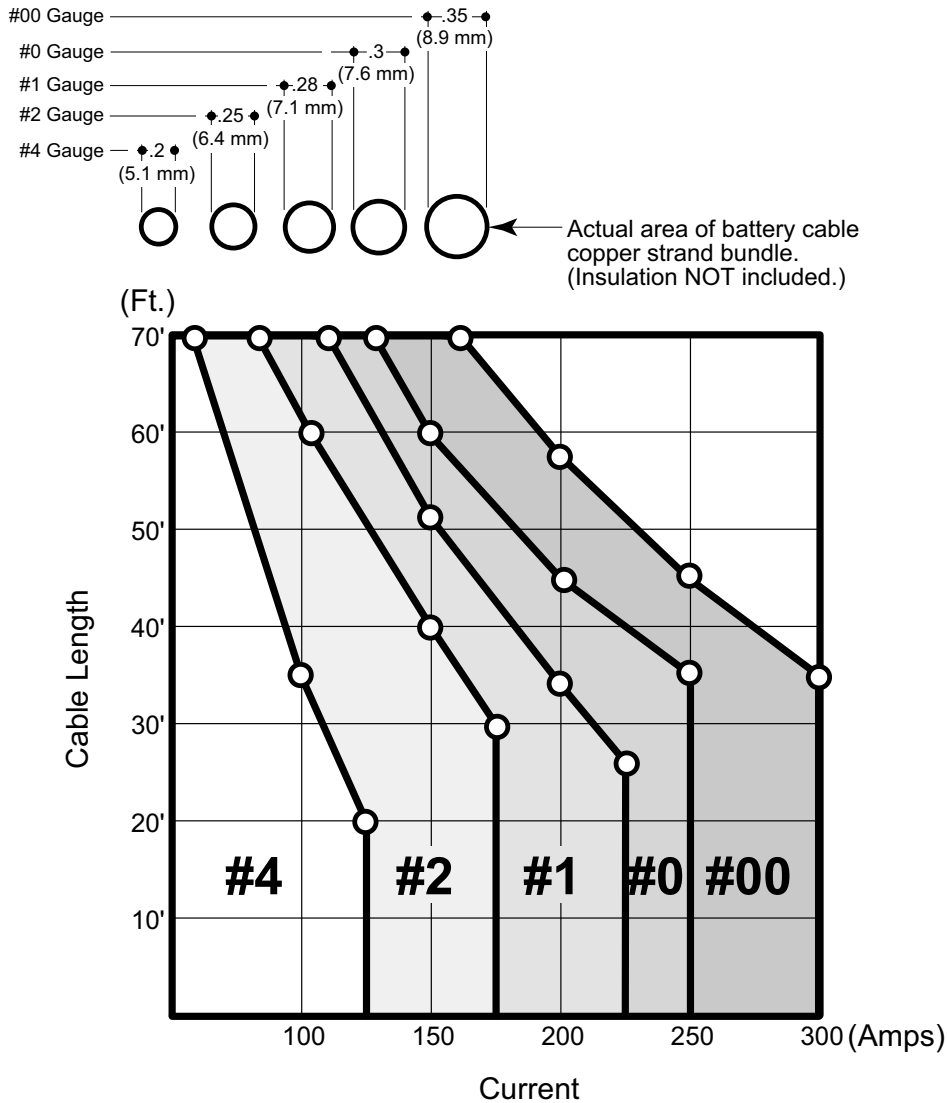

- For best results, Monarch would recommend that you increase 1 or 2 cable sizes above the minimum shown above. Select cable size so that your cable length and maximum amp draw falls below and to the left of curve.
- Curve describes a 1 volt loss in the battery cable itself.
- Total length of battery cable(s) including all ground cables.

Example: With maximum current draw of 200 amps and total cable length of 28 ft (7.82m), Select #1 gauge (.28 in/7.1mm) or larger.

Limited 1 Year Warranty

Monarch Hydraulics, Inc. ("Monarch") makes the following warranty to any party who purchases this Monarch product *directly* from Monarch with the intention of either reselling this Monarch product or incorporating it into or attaching it to some other product ("the purchaser").

Monarch warrants to the purchaser that this product is free from any substantial defects in materials and workmanship. If this product proves to be defective in materials or workmanship during the period of this warranty, Monarch will repair or replace, at its option, the defective product free of charge (except for transportation charges as provided below). The period of this warranty is the (1) year period beginning from the date of shipment of this Monarch product by Monarch to the purchaser.

To obtain warranty service, the purchaser must call Monarch to have a return goods authorization number assigned to them. The purchaser should then send the product claimed to be defective within the warranty period, transportation prepaid, to: Monarch Hydraulics, Inc., 1363 Michigan Street N.E., Grand Rapids, MI. 49503. Monarch will then repair or replace, at its option, items which it finds to have been defective. Monarch will return such repaired or replacement items to the sender free of charge. Items claimed by the purchaser, but not found by Monarch, to be defective will be returned to the purchaser by a reasonably expeditious means at the purchaser's expense. This expense may include labor charges incurred from inspecting the unit.

This warranty does not extend to any failure of this Monarch product to perform as warranted hereinabove which is caused by misuse, abuse or material alteration of this product, or any negligence in connection with the installation, service, or use of this product by any person other than Monarch.

Monarch hereby expressly disclaims any liability for consequential damages to property other than this Monarch product to perform as warranted hereinabove.

Note: Supersedes all former warranties written or implied.



Monarch D.C. Hydraulic Power Systems

NOTES :

Distributed By:



U.S.A.:
MONARCH HYDRAULICS, INC.
P.O. Box 1764, Grand Rapids, MI 49501-1764, U.S.A.
1363 Michigan St NE, Grand Rapids, MI 49503, U.S.A.
Telephone: (616) 458-1306
Telefax: (616) 458-1616
<http://www.monarchhyd.com>

CANADA:
FLUID-PACK CORPORATION
A Part of the Monarch Hydraulics Group
460 Newbold St., London, Ontario, Canada N6E 1K3
Telephone: (519) 686-5900
Telefax: (519) 686-8976
www.fluidpack.com

CHINA:
ZHAOQING MONARCH HYDRAULICS CO. LTD.
5F, 434, Yeuxiu Road North
Guangzhou, 510050, PRC
Telephone: 0758-3642371
Telefax: 0758-3642373
www.monarch-hyd.cn